

**REGULATION OF METABOLIC EFFECTS IN L6 MUSCLE CELLS BY
SULFONYLUREAS AND THE PROTEIN TYROSINE PHOSPHATASE
INHIBITORS VANADATE AND PERVANADATE.**

by

Evangelia Tsiani

**A thesis submitted in conformity with the requirements
for the degree of Doctor of Philosophy,
Graduate Department of Physiology,
University of Toronto**

© Copyright by Evangelia Tsiani (1997)



National Library
of Canada

Bibliothèque nationale
du Canada

Acquisitions and
Bibliographic Services

Acquisitions et
services bibliographiques

395 Wellington Street
Ottawa ON K1A 0N4
Canada

395, rue Wellington
Ottawa ON K1A 0N4
Canada

Your file *Votre référence*

Our file *Notre référence*

The author has granted a non-exclusive licence allowing the National Library of Canada to reproduce, loan, distribute or sell copies of this thesis in microform, paper or electronic formats.

L'auteur a accordé une licence non exclusive permettant à la Bibliothèque nationale du Canada de reproduire, prêter, distribuer ou vendre des copies de cette thèse sous la forme de microfiche/film, de reproduction sur papier ou sur format électronique.

The author retains ownership of the copyright in this thesis. Neither the thesis nor substantial extracts from it may be printed or otherwise reproduced without the author's permission.

L'auteur conserve la propriété du droit d'auteur qui protège cette thèse. Ni la thèse ni des extraits substantiels de celle-ci ne doivent être imprimés ou autrement reproduits sans son autorisation.

0-612-28073-X

Canada

**REGULATION OF METABOLIC EFFECTS IN L6 MUSCLE CELLS BY
SULFONYLUREAS AND THE PROTEIN TYROSINE PHOSPHATASE (PTP)
INHIBITORS VANADATE AND PERVANADATE.**

**A thesis by Evangelia Tsiani submitted in conformity with the requirements for
the degree of Doctor of Philosophy, Graduate Department of Physiology,
University of Toronto.**

ABSTRACT

Non-insulin-dependent or Type II diabetes mellitus (NIDDM) is a disease characterized by insulin deficiency and insulin resistance. Treatment is directed at improving either one or both of these abnormalities. The most commonly used pharmacological agents to treat NIDDM are the sulfonylurea drugs. A controversial and unanswered question about sulfonylureas is whether they possess any direct actions on peripheral insulin target tissues. The effects of gliclazide and glyburide on glucose uptake in L6 skeletal muscle cells, a model of a major insulin target tissue, were investigated. These studies demonstrate that gliclazide and glyburide similarly increase glucose transport into L6 cells which is associated with an increase in total cellular and plasma membrane GLUT1 glucose transporter levels. The mechanism appears to involve stabilization of GLUT1 at the plasma membrane.

Since many patients with NIDDM do not respond to currently available oral hypoglycemic agents, a great deal of research into understanding insulin action and resistance and the development of novel agents is ongoing. Vanadium compounds are protein tyrosine phosphatase inhibitors which have been useful probes to study insulin signalling and have also been proposed as potential therapeutic agents. The effects of the vanadium compounds sodium orthovanadate and pervanadate on glucose and amino acid transport and their mechanism of action were investigated. The results demonstrate that vanadate and pervanadate mimic insulin to stimulate glucose transport in L6 cells but inhibit amino acid (MeAIB) transport by the insulin-sensitive system A transporter. The data suggest that this inhibition may be mediated by inhibition of a protein tyrosine phosphatase. It was also found that the stimulation of glucose

transport by vanadate and pervanadate is mediated by a signalling pathway that differs from that of insulin and importantly is independent of PI 3-kinase, the enzyme involved in the insulin signalling of glucose transport.

These findings contribute new knowledge to our understanding of the effects and mechanisms of action of the oral hypoglycemic sulfonylurea drugs and vanadium compounds. Taken together the results support the continued use of sulfonylureas and the potential use of vanadium compounds in disease associated with insulin resistance.

PREFACE

The work included in this thesis was performed in the laboratory of Dr. I. George Fantus at the Banting and Best Diabetes Center, Max Bell Research Wing, Toronto General Hospital, Toronto, Ontario, Canada under the supervision of Dr. I. George Fantus in the period of 1991-96. Financial support was provided by the State Scholarship Foundation of Greece, and The University of Toronto to me, and grants from Servier Canada Inc., the Medical Research Council of Canada (MT-7658) and the Canadian Diabetes Association to Dr. I. George Fantus.

The results included in this thesis have been presented in one published paper, two manuscripts in press and one manuscript submitted.

1. E. Tsiani, T. Ramlal, L. Leiter, A. Klip and I.G. Fantus. Stimulation of glucose uptake and increased plasma membrane content of glucose transporters in L6 skeletal muscle cells by the sulfonylureas gliclazide and glyburide. **Endocrinology** 136:2505-2512. 1995

2. E. Tsiani, N. Abdullah and I.G. Fantus. Insulin mimetic agents vanadate and pervanadate stimulate glucose but inhibit amino acid uptake. **American Journal of Physiology** (In press).

3. E. Tsiani and I.G. Fantus. Vanadium compounds: Biological actions and potential as pharmacological agents. **Trends in Endocrinology and Metabolism** (In press).

4. E. Tsiani, A. Sorisky and I.G. Fantus. Vanadate and pervanadate stimulate glucose uptake in L6 skeletal muscle cells by a mechanism independent of phosphatidylinositol 3-kinase, and protein kinase C (submitted).

ACKNOWLEDGMENTS

I would like to express my gratitude to my Supervisor Dr. I. George Fantus for his guidance, support and encouragement during the course of this work. I also thank him for giving me the opportunity to work in his laboratory and his understanding and assistance in matters not directly related to my research project. His patient, enthusiasm for science and excellent advice were fundamental towards the success of my graduate training.

I appreciate the excellent advice and guidance of my Ph. D. progress committee members Dr. Amira Klip and Dr. Cecil Yip, and thank them for the careful reading of this manuscript and also for writing reference letters for me. Special thanks to Amira for her support and for inviting me to many social events to meet other invited researchers and professors.

I am beholden to the members of the examination committee for the careful reading of this thesis and especially to Dr. Posner for his critical appraisal of my work and for making the effort to come to Toronto. I thank Dr. Mladen Vranic for his support and for writing reference letters for me as well as for his constant interest in my progress.

Thanks also to Dr. A. Giacca and to graduate coordinator in the Department of Physiology, Dr. U. De Boni for reading this manuscript. I acknowledge the assistance of Dr. U. De Boni in finishing on time. I thank Dr. David Irwin for letting me use his computer for printing my thesis. Many thanks to the postdoctoral fellow in the lab when I joint it, Dr. L. Stern for teaching me so much the first year of my Ph. D. studies and for providing a positive and friendly environment.

I thank Toolsie Ramlal who taught me the membrane fractionation technique. Thanks also to all coworkers past and present; they all taught me something about research and life, even the very negative ones. Special thanks to Mrs. Barbara Baubinas for her secretarial assistance and her friendly and positive attitude.

I gratefully acknowledge the financial support of the State Scholarship foundation of Greece for the first year of my Ph.D. studies and the University of Toronto for the financial support in the subsequent years.

Most of all I would like to acknowledge the constant support and encouragement of my family and my husband's family. My Mom helped me with my newly born daughter and inspired me to work hard and write fast this manuscript and my parents-in-law took care of my daughter during the writing of this thesis.

The support, help and encouragement of my husband Theodoros Tsakiridis has been unparalleled. Without his help, understanding, love and his positive input in my studies this thesis would have been very hard to accomplish.

To my daughter Evangelia Evelyn Tsakiridis.
She is the most important and precious thing in my life.

TABLE OF CONTENTS

ABSTRACT	ii
PREFACE	iii
ACKNOWLEDGEMENTS	iv
DEDICATION	vi
TABLE OF CONTENTS	viii
LIST OF FIGURES	xii
LIST OF TABLES	xiv
ABBREVIATIONS	xv

CHAPTER 1

GENERAL BACKGROUND	1
1.1 INSULIN ACTION	2
1.1.1 Physiological Role of insulin	2
1.1.2 Diabetes Mellitus	4
1.2 MECHANISMS OF INSULIN SIGNALLING	4
1.2.1 The Insulin Receptor	4
1.2.2 Insulin signalling pathways	7
1.2.2.1 Insulin Receptor Substrate-1 (IRS-1)	7
1.2.2.2 Src homology and collagen like (Shc) proteins	10
1.2.2.3 Grb2 -associated binder 1 (Gab-1) and p60	11
1.2.2.4 Phosphatidylinositol 3-kinase (PI 3-kinase)	11
1.2.2.4.1 Characterization of the enzyme	11
1.2.2.4.2 Physiological role of PI 3-kinase	13
1.2.2.5 Ras-MAPK pathway	16
1.2.2.5.1 Growth factor Receptor Binding protein 2 (GRB-2) and Sos	16
1.2.2.5.2 Ras	17
1.2.2.5.3 The Raf kinase	18
1.2.2.5.4 MAPKK or ERK kinase (MEK) and mitogen-activated protein kinase (MAPK)	19
1.3 GLUCOSE TRANSPORT AND GLUCOSE TRANSPORTERS	20
1.3.1 Facilitative glucose transporters	21
1.3.1.1 The transporter family	21
1.3.1.2 Biochemical properties and tissue distribution of glucose transporters	23
1.3.1.2.1 GLUT1	23
1.3.1.2.2 GLUT2	23
1.3.1.2.3 GLUT3	24
1.3.1.2.4 GLUT4	24
1.3.1.2.5 GLUT5	24
1.3.1.2.6 GLUT6	25
1.3.1.2.7 GLUT7	25
1.3.1.3 Cellular localization of glucose transporters	26
1.3.2 Regulation of glucose transport	26
1.3.2.1 Long term regulation of glucose transport and transporter expression	26
1.3.2.2 Short term regulation of glucose transport	27
1.3.2.3 Intracellular traffic of glucose transporters	28
1.3.2.4 Cellular components involved in the regulation of glucose transport	29
1.3.2.4.1 Signalling molecules involved in insulin-stimulation of glucose transport	29
1.3.2.4.1.1 Role of PI 3-kinase	29
1.3.2.4.1.2 Role of Ras	31
1.3.2.4.1.3 Role of Raf	32
1.3.2.4.1.4 Role of MAPK	32
1.3.2.4.2 Protein Kinase C (PKC)	33

1.3.2.4.2.1	Activation of PKC	35
1.3.2.4.2.2	Involvement of PKC in glucose transport	37
1.3.2.4.3	The actin network	38
1.3.2.4.3.1	Actin	38
1.3.2.4.3.2	Role of actin in glucose transport	39
1.4	AMINO ACID TRANSPORT	40
1.4.1	Physiological importance of amino acids	40
1.4.2	Systems of amino acid transport in mammalian tissues	41
1.4.3	Regulation of system A amino acid transport	44
1.5	L6 MUSCLE CELLS	46
1.7	RATIONALE	52
CHAPTER 2		54
BACKGROUND ON SULFONYLUREA COMPOUNDS		54
2.1	SULFONYLUREA DRUGS IN THE TREATMENT OF DIABETES	55
2.2	BIOCHEMICAL CHARACTERISTICS OF SULFONYLUREA COMPOUNDS	55
2.3	EFFECTS OF SULFONYLUREAS	58
2.3.1	Pancreatic effects of sulfonylureas	58
2.3.1.1	Insulin secretion	58
2.3.1.2	Other pancreatic effects	60
2.3.2	Extrapancreatic effects of sulfonylureas on fat and muscle cells	60
2.3.3	Effects of Sulfonylureas on liver	61
2.3.4	Effect on glucose transport in the intestine	63
2.3.5	Other effects of sulfonylureas	63
2.4	SULFONYLUREA SIGNALLING	64
2.4.1	The sulfonylurea receptor	64
2.4.2	Mechanism of action of sulfonylureas in the pancreas	66
2.4.3	Possible mechanism of action of sulfonylureas in peripheral tissues.	68
2.4.3.1	Effect of sulfonylureas on insulin binding and insulin receptor kinase activity.	68
2.4.3.2	Effect on glucose transport and glucose transporters	69
2.4.3.3	Role of PKC in the sulfonylurea-induced increase in glucose transport	70
2.5	SUMMARY	71
CHAPTER 3		73
EFFECTS OF THE SULFONYLUREAS GLICLAZIDE AND GLYBURIDE ON GLUCOSE TRANSPORT AND GLUCOSE TRANSPORTERS IN MUSCLE CELLS		73
3.1	ABSTRACT	74
3.2	INTRODUCTION	75
3.3	MATERIALS AND METHODS	75
3.3.1	Materials	75
3.3.2	Cell cultures and Drug treatment.	76
3.3.3	Glucose uptake (2-deoxyglucose uptake assay).	77
3.3.4	Preparation of membrane fractions.	77
3.3.5	Immunoblotting.	78
3.4	RESULTS	79
3.4.1	Time-dependent effect of gliclazide and glyburide on glucose uptake.	79
3.4.2	Concentration-dependent effect of gliclazide and glyburide on glucose uptake	79
3.4.3	Effect of sulfonylurea treatment on insulin-stimulated glucose uptake	82

3.4.4	Effect of cycloheximide on gliclazide and glyburide-stimulated glucose uptake	84
3.4.6	Effect of gliclazide and glyburide on glucose transporter levels and distribution	84
3.4.7	Effect of cycloheximide on glyburide-induced increase in plasma membrane GLUT1	87
3.6	CONCLUSIONS	96
CHAPTER 4		97
BACKGROUND ON VANADIUM COMPOUNDS		97
4.1	VANADIUM	98
4.1.1.	Physiological importance	98
4.2	CHEMISTRY OF VANADIUM AND PEROXOVANADIUM COMPOUNDS	99
4.2.1	Vanadate	99
4.2.2	Pervanadate	102
4.3	TRANSPORT INTO CELLS	104
4.4	ENZYME INTERACTIONS	105
4.5	METABOLIC ACTIONS	106
4.5.1	Actions opposite to insulin	106
4.6	NONMETABOLIC ACTIONS OF VANADATE	108
4.7	IN VIVO EFFECTS OF VANADATE	109
4.8	MECHANISM OF INSULIN MIMETIC ACTION OF VANADATE	113
4.8.1	Protein Tyrosine Phosphatase (PTP) inhibition.	113
4.8.2	Effect on insulin receptor and insulin receptor kinase	115
4.8.3	Role of cytosolic tyrosine kinase	116
4.8.4	Role of insulin signalling molecules	117
4.8.4.1	Role of PI 3-kinase	117
4.8.4.2	Role of MAPK	117
4.8.4.3	Vanadate effect on glucose transporters.	118
4.8.5.	Pancreatic effects of vanadate	118
4.8.6	Other contributions to glucose-lowering action	119
4.9	POTENTIAL SIDE EFFECTS AND TOXICITY OF VANADIUM COMPOUNDS	120
4.10	SUMMARY	121
CHAPTER 5		123
THE INSULIN-MIMETIC AGENTS VANADATE AND PERVANADATE STIMULATE GLUCOSE BUT INHIBIT AMINO ACID UPTAKE IN MUSCLE CELLS.		123
5.1	ABSTRACT	124
5.2	INTRODUCTION	125
5.3	MATERIALS AND METHODS	126
5.3.1	Materials	126
5.3.2	Cell Cultures	126
5.3.3	Drug treatment, glucose and amino acid uptake assay.	127
5.3.4	Statistical analysis	127
5.4	RESULTS	128
5.4.1	Effect of vanadate and pervanadate on glucose and amino acid uptake.	128
5.4.2	Effect of vanadate and pervanadate in combination with insulin.	128
5.4.3	Effect of insulin and pervanadate on the kinetics of amino acid transport.	131
5.4.4	Effect of ouabain on basal and insulin-stimulated MeAIB uptake	134
5.4.5	Effect of vanadate on adaptive regulation of amino acid uptake	134
5.4.6	Effect of cycloheximide on PTP inhibitor action	138
5.4.7	Effect of vanadate and pervanadate on MeAIB uptake in	

hepatoma cells	138
5.5 DISCUSSION	141
5.6 CONCLUSIONS	144
CHAPTER 6	145
MECHANISM OF ACTION OF VANADATE AND PERVANADATE TO STIMULATE GLUCOSE UPTAKE IN MUSCLE CELLS	145
6.1 ABSTRACT	146
6.2. INTRODUCTION	147
6.3. MATERIALS AND METHODS	148
6.3.1. Materials	148
6.3.2. Cell cultures	148
6.3.3. Drug treatment and glucose uptake assay	149
6.3.4. Immunoprecipitations	149
6.3.5. In vitro PI3 Kinase activity assay	150
6.3.6. Determination of PI 3 kinase lipid products in intact cells	150
6.4. RESULTS	151
6.4.1. Effect of wortmannin on insulin- vanadate- and pV-stimulated glucose uptake	151
6.4.2. Wortmannin blocks in vitro PI 3-kinase activity	153
6.4.3. Generation of the PI 3-kinase lipid products in intact cells	153
6.4.4. Inhibition of MEK does not block glucose transport stimulation	156
6.4.5. Vanadate- and pV-stimulated glucose transport does not involve PKC	156
6.4.6. Cytochalasin D inhibits insulin-, vanadate- and pV-stimulated glucose transport	160
6.5. DISCUSSION	163
6.4. CONCLUSIONS	165
CHAPTER 7	166
OVERALL DISCUSSION	166
REFERENCES	178
COPYRIGHT RELEASE AUTHORIZATIONS	210

LIST OF FIGURES

CHAPTER 1

Figure 1.1	Regulation of blood glucose levels	3
Figure 1.2	Structure of the insulin receptor	5
Figure 1.3	Insulin signalling pathways	8
Figure 1.4	PI 3-kinase signalling pathway	14
Figure 1.5	Structure of the facilitative glucose transporters	22
Figure 1.6	Isoforms of PKC	34
Figure 1.7	Activation of PKC	36
Figure 1.8	L6 skeletal muscle cells in the myoblast and the myotube stage	47

CHAPTER 2

Figure 2.1	Structure of sulfonylurea drugs	57
Figure 2.2.	Mechanism of insulin secretion in b-cells and mechanism of sulfonylurea action	67
Figure 2.3	Action of sulfonylureas in NIDDM	72

CHAPTER 3

Figure 3.1	Effect of gliclazide (A) and glyburide (B) on 2-deoxyglucose uptake in L6 myotubes. Time-course	80
Figure 3.2	Effect of gliclazide (A) and glyburide (B) on 2-deoxyglucose uptake in L6 myotubes. Dose-response	81
Figure 3.3	Effect of sulfonylurea treatment on basal and insulin-stimulated glucose uptake	83
Figure 3.4	Effect of cycloheximide (CHX) on basal and gliclazide or glyburide-stimulated glucose uptake in L6 myotubes	85
Figure 3.5	Effect of gliclazide and glyburide on the levels and distribution of glucose transporters in L6 skeletal muscle cells	86
Figure 3.6	Effect of gliclazide and glyburide on the total levels of glucose transporters in L6 skeletal muscle cells	88
Figure 3.7	Effect of gliclazide and glyburide on the plasma membrane levels of glucose transporters in L6 skeletal muscle cells	89
Figure 3.8	Effect of cycloheximide (CHX) on basal and glyburide induced changes in plasma membrane and internal membrane levels of GLUT1.	92

CHAPTER 4

Figure 4.1	Similarity of structure and charge among phosphate, vanadate and pervanadate.	100
Figure 4.2	Sites of potential protein tyrosine phosphatase (PTP) inhibition by vanadium compounds	114

CHAPTER 5

Figure 5.1	Effect of vanadate and pervanadate on glucose and amino acid transport; Time course	129
------------	---	-----

Figure 5.2	Effect of vanadate and pervanadate on glucose and amino acid transport; Dose-response	130
Figure 5.3	Dose-dependent inhibition of insulin-stimulated MeAIB uptake by pervanadate 133	
Figure 5.4	Effect of insulin and pervanadate on the kinetics of amino acid transport in L6 muscle cells	135
Figure 5.5	Effect of ouabain on basal and insulin-stimulated MeAIB uptake	136
Figure 5.6	Effect of vanadate and pervanadate on basal and insulin-stimulated MeAIB uptake in hepatoma cells	140
 CHAPTER 6		
Figure 6.1	Effect of insulin, vanadate and pV on glucose transport in muscle cells	152
Figure 6.2	Effect of wortmannin on insulin, vanadate and pV stimulation of glucose transport in myotubes	154
Figure 6.3	Effect of wortmannin on PI 3-kinase activity stimulated by insulin and pV	155
Figure 6.4	Effect of wortmannin on insulin, vanadate and pV stimulation of synthesis of lipid products	157
Figure 6.5	The MEK inhibitor PD 098059 does not affect insulin-, vanadate- or pV-stimulated glucose transport	158
Figure 6.6	Effect of PKC downregulation on insulin and pV action on glucose transport in myotubes	159
Figure 6.7	Cytochalasin D inhibits insulin-, vanadate- and pV-stimulated glucose transport	162
 CHAPTER 7		
Figure 7.1	Possible sites of action of sulfonylureas in L6 muscle cells to effect GLUT1 stabilization at the plasma membrane	169
Figure 7.2	Stimulation of glucose transport by vanadium compounds	174

LIST OF TABLES

CHAPTER 1

Table 1.1.	Amino acid transport systems in mammalian cells	42
------------	---	----

CHAPTER 2

Table 2.1	Oral hypoglycemic agents used in the treatment of Type II Diabetes	56
Table 2.2	Effect of sulfonylureas on glucose uptake in tissues and cell culture models of insulin targets	62

CHAPTER 3

Table 3.1	Effect of gliclazide and glyburide on the internal membrane levels of glucose transporters in L6 myotubes	90
-----------	---	----

CHAPTER 4

Table 4.1	Available vanadium salts	103
Table 4.2	Insulin-like effects of vanadium compounds in insulin target tissues	107
Table 4.3	Rodent models of diabetes and/or insulin resistance treated with vanadium compounds	111

CHAPTER 5

Table 5.1	Effect of vanadate and pervanadate (pV) on insulin-stimulated glucose and amino acid transport	132
Table 5.2	Effect of vanadate on adaptive regulation of system A amino acid transport	137
Table 5.3	Effect of cycloheximide on insulin, vanadate and pervanadate induced changes in glucose and amino acid uptake	139

CHAPTER 6

Table 6.1	Effect of PKC inhibitors on insulin, vanadate and pV-stimulated glucose transport	161
-----------	---	-----

ABBREVIATIONS

a-MEM	Eagle's minimum essential medium-a
ADP	adenosine diphosphate
AMP	adenosine 5'-monophosphate
ATB-BMPA	2- <i>N</i> -[4-(1-azi-2,2,2-trifluoroethyl)benzoyl]-1,3-bis-(<i>D</i> -mannose-4-yloxy)-2-propylamine
ATP	adenosine triphosphate
³ H-2DG	2-Deoxy- ³ H-D-glucose
BIM	bisindolylmaleimide
BSA	bovine serum albumin
CB	cytochalasin B
CD	cytochalasin D
cAMP	Adenosine 3'-5'-cyclic monophosphate
DMSO	dimethyl sulphoxide
DNP	2,4-dinitrophenol
ECL	Enhanced Chemiluminescence
EDTA	ethylenediaminetetraacetic acid
EGF	epidermal growth factor
EGTA	ethylene glycol-bis(b-aminoethyl ether)- <i>N,N,N',N'</i> -tetraacetic acid
FBS	fetal bovine serum
GLUT	glucose transporter
GRB-2	growth factor receptor binding protein 2
GTP	guanosine triphosphate
HBS	HEPES-buffered saline
HEPES	<i>N</i> -2-hydroxyethylpiperazine- <i>N'</i> -2-ethanesulfonic acid
IC ₅₀	50% inhibitory concentration
IDDM	insulin dependent diabetes mellitus
IGF	insulin-like growth factor
IM	internal membranes
IP ₃	inositol-1,4,5-triphosphate
IRS-1	insulin receptor substrate-1
kb	kilobase(s)
kDa	kiloDalton(s)
LY2924002	2-(4-morpholinyl)-8-phenyl-4H-1-benzopyran-4-one
MAPK	mitogen-activated protein kinase
Na ⁺ /K ⁺ -ATPase	sodium and potassium-dependent adenosine triphosphatase
NIDDM	non-insulin dependent diabetes mellitus
p85	85 kDa regulatory subunit of Phosphatidyl Inositol 3-Kinase
p110	phosphatidylinositol 3-kinase catalytic 110 kDa subunit
PAGE	polyacrylamide gel electrophoresis
PBS	phosphate-buffered saline
PDGF	platelet-derived growth factor
PI	phosphatidylinositol
PI 3-kinase	phosphatidylinositol 3-kinase
PI3P	PI-3-monophosphate
PI3,4P	PI-3,4-bisphosphate
PI3,4,5P	PI-3,4,5-triphosphate
PI4P	PI-4-monophosphate
PI4,5P	PI-4,5-bisphosphate
PKA	protein kinase A
PKB	serine/threonine kinase also known as Akt/Rac
PKC	protein kinase C
PLC	phospholipase C

PM	plasma membrane fraction
PMSF	phenylmethanesulfonylfluoride
pV	pervanadate
PVDF	polyvinylidene difluoride
SDS	sodium dodecyl sulphate
SE	standard error
SH2	<i>src</i> homology 2 domain
SH3	<i>src</i> homology 3 domain
Sos	son-of sevenless
STZ	streptozotocin
TM	total membranes
Tyr	tyrosine
VAMP	vesicle-associated membrane protein
Vps34	<i>Saccharomyces cerevisiae</i> isoform of PI 3-kinase
Vps15	a serine/threonine kinase associated with Vps34

CHAPTER 1
GENERAL BACKGROUND

1.1 INSULIN ACTION

1.1.1 Physiological Role of insulin

Insulin is a pancreatic hormone which consists of two polypeptide chains derived from one gene and connected by two disulfide bonds (1). It is synthesized, stored and released by the β -cells of the pancreatic islets and together with the other pancreatic hormones, glucagon and somatostatin, plays an important role to maintain blood glucose homeostasis (Figure 1.1). In particular, insulin is the key determinant of blood glucose levels following a meal. Following the digestion of food and absorption of glucose by the intestine into blood, the blood glucose levels increase. In healthy individuals this rise in blood glucose along with neural and incretin (GI hormonal factors) results in secretion of insulin from the β -cells of the pancreas.

Through the circulation, insulin reaches almost all cells in the body. Its most important metabolic targets are fat, muscle and liver cells. Insulin action at the cellular level is initiated by binding of insulin to its receptor. Although the hormone regulates cellular metabolic processes by alteration of the functions at the plasma membrane, intracellular enzymes and the nucleus, the exact mechanism whereby receptor signalling results in different insulin-mediated cellular effects is not completely defined (2). In skeletal and cardiac muscle and fat tissues insulin stimulates glucose transport and metabolism while in the liver it inhibits glucose production, by inhibiting both glycogen breakdown and gluconeogenesis from amino acids, glycerol and lactate. The net result of these actions of the hormone is to maintain the blood glucose levels back to normal (Figure 1.1). Insulin also promotes in cells anabolic events such as synthesis of glycogen, lipids and proteins. Once inside the muscle cells, glucose is either catabolised or converted into glycogen that can be easily broken down or oxidized when it is needed, while in fat cells glucose is utilized for fat synthesis which is used for long term energy storage. When blood glucose levels return to normal, insulin secretion decreases to basal levels as does the rate of glucose transport into insulin responsive tissues.

Figure 1.1 Regulation of blood glucose levels

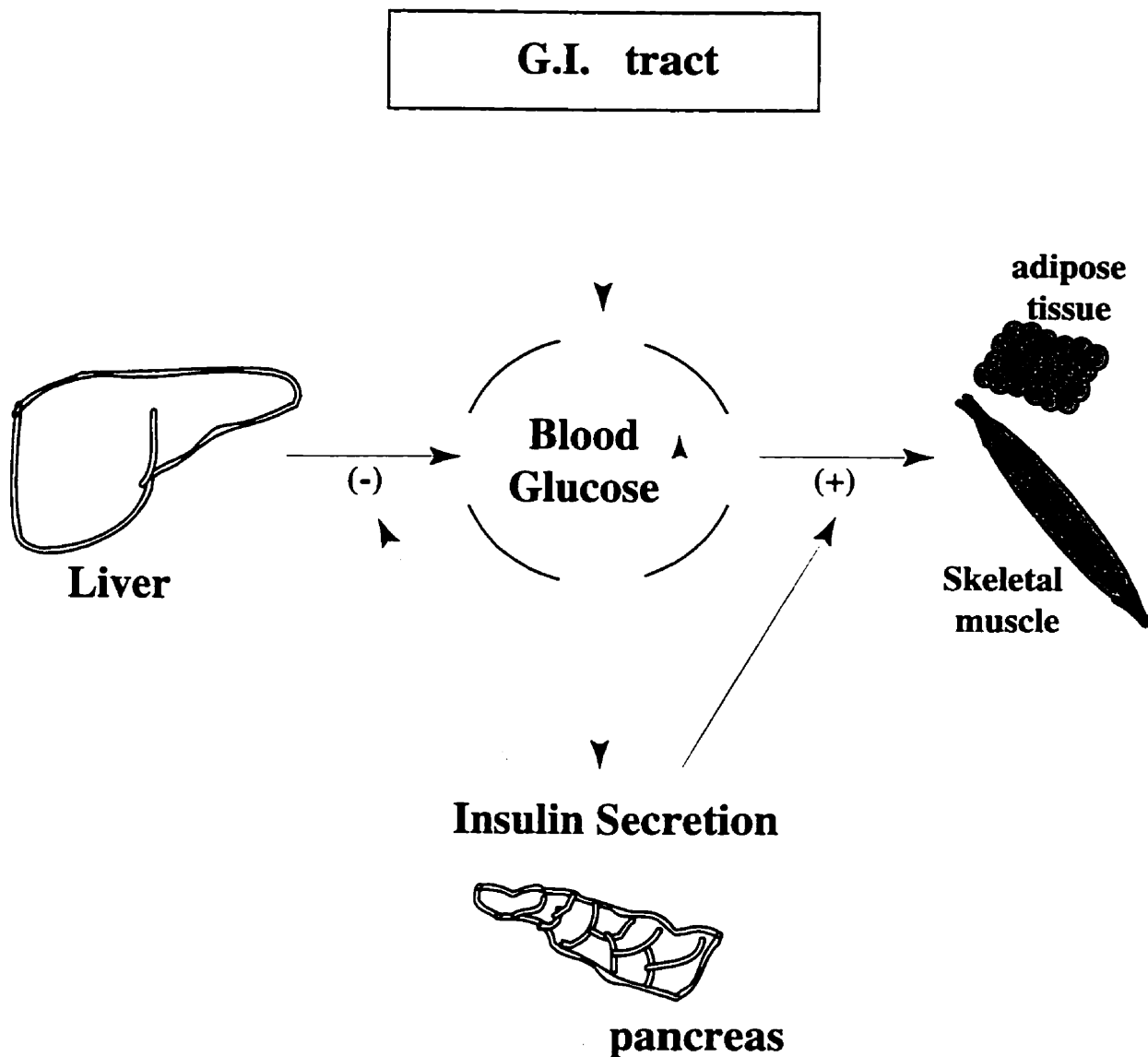

Blood glucose levels are increased following a meal and the absorption of glucose by the intestine. Insulin is released by the pancreas in response to this increase and through the circulation reaches all the cells. In the liver insulin inhibits glucose production and output while in fat and muscle cells stimulates glucose uptake. The net result of these actions of insulin is the maintenance of blood glucose to normal levels.

1.1.2 Diabetes Mellitus

Deficiency of insulin or a lack of insulin action will result in a disturbance of glucose homeostasis. If blood glucose levels rise above a defining threshold (e.g. 7.8 mmol/L in the fasting state) the disease called diabetes mellitus is present (3,4). Depending on etiology, diabetes is categorized into Type I and Type II. The Type I or Insulin Dependent Diabetes Mellitus (IDDM) usually appears early in life and is mainly due to destruction of the pancreatic β -cells and a severe deficiency of insulin secretion. Therapy in these individuals consists of exogenous insulin administration. Type II or Non-Insulin Dependent Diabetes Mellitus (NIDDM) usually appears later in life. Although heterogeneous, it is more likely to occur in obese individuals and is associated with reduced insulin sensitivity or insulin resistance of the insulin target tissues as well as reduced insulin secretion. Management of the disease in these individuals may be achieved with the use of oral hypoglycemic agents and/or exogenous insulin supplementation.

1.2 MECHANISMS OF INSULIN SIGNALLING

1.2.1 The Insulin Receptor

The action of insulin in its target cells begins with the binding of insulin to its receptor located at the plasma membrane. The insulin receptor is expressed in almost all mammalian cells and consists of two α and two β subunits (Figure 1.2). The α subunits are linked to each other and each to a β -subunit by disulfide bonds (5). The α and β subunits are products of a single gene and are derived by proteolytic cleavage of a single precursor protein (6). The insulin binding site is located in the α -subunits (135 kDa, 719 amino acids (aa)) which are entirely extracellular while the transmembrane β -subunits (95 kDa, 620 aa) contain a tyrosine kinase domain in their cytoplasmic portion. Upon binding of insulin to the α -subunit of the receptor, conformational changes take place which result in the activation of the tyrosine kinase of the β -subunit of the receptor (7,8). This results in autophosphorylation of tyrosines within the

Figure 1.2 Structure of the insulin receptor

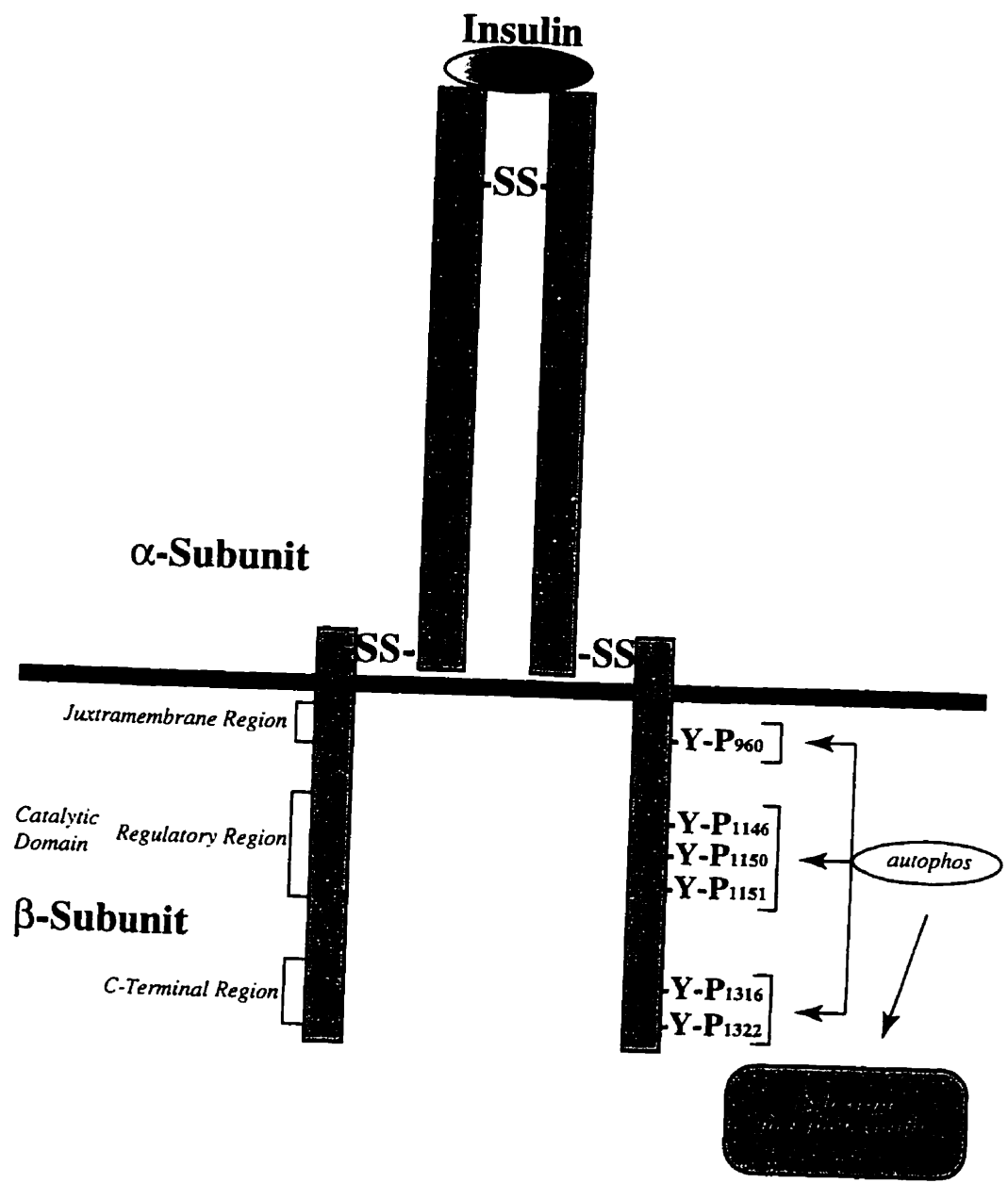

The insulin receptor consists of two α - and two β -subunits. The α -subunits contain the insulin binding site and are linked to each other and each to a β -subunit by disulfide bonds. The β -subunits span the plasma membrane and in their cytoplasmic portion contain a tyrosine kinase (see text for more explanations).

cytoplasmic juxtamembrane region, the COOH-terminus and the regulatory region of the kinase domain (9). The autophosphorylation reaction is an intramolecular one, in which one β -subunit transphosphorylates the other β -subunit, and results in a further increase in the tyrosine kinase activity leading to tyrosine phosphorylation of a variety of intracellular substrate proteins (10,11). Once autophosphorylation has taken place, particularly of the regulatory tyrosines 1146, 1150, 1151 (numbering according to Ullrich) (12) the binding of insulin to the α subunit is no longer required for its continued activity and the receptor is inactivated only by dephosphorylation (13). Upon insulin stimulation the β subunits are also serine phosphorylated (14). The physiological importance of the serine phosphorylation is not clear but may play a regulatory role on receptor activity.

Kasuga et al (5) and Rosen (reviewed in (11)) were the first to show that the insulin receptor is a tyrosine kinase. The insulin receptor tyrosine kinase activity is required to mediate the effects of insulin. Thus studies done in cells with mutant insulin receptors in which the tyrosine kinase is absent show a lack of insulin signalling (15,16). Point mutation of lysine 1018 abolishes ATP binding and tyrosine kinase activity and abrogates insulin signalling in cultured cells (17). Other tyrosine residues within the kinase domain are also very important for the propagation of insulin signalling, as it has been demonstrated by point mutation studies. Furthermore, mutation of the regulatory tyrosine 1146, 1150 and/or 1151 also results in decreased tyrosine kinase activity and insulin action (18). As well cells from insulin resistant diabetic patients may exhibit a defect in insulin receptor tyrosine kinase activation (19,20). The phosphorylated tyrosine residues not in the regulatory domain also have distinct functions. Tyrosine 960 (juxtamembrane) is required for effective substrate phosphorylation of IRS-1 (see below). The COOH terminal tyrosines may be involved in regulating the growth effects of insulin since a mutant insulin receptor lacking 43 amino acids from the COOH terminal results in a loss of insulin metabolic responses and an enhancement of mitogenic responses (21,22).

Following insulin binding to the receptor, clustering of receptors occurs (23) followed by receptor internalization (24,25). The role of these events in the signalling of the insulin receptor

is not clear but there is evidence for the presence of enhanced tyrosine kinase activity of the internalized insulin receptor (24).

1.2.2 Insulin signalling pathways

The increase in the tyrosine kinase activity of the insulin receptor results in tyrosine phosphorylation of a variety of intracellular substrate proteins namely IRS-1 (insulin receptor substrate-1), IRS-2, Shc (Src homology and collagen like), Gab1 (growth factor receptor bound protein 2 (Grb2) associated binder 1) (26) and a 60 KDa protein (p60) (27). All of these may be termed “docking proteins” since upon tyrosine phosphorylation they are able to bind to other signalling molecules (see below). These signalling molecules then undergo changes in binding properties or activity to transmit the variety of different signals of insulin. The final biological effects such as the enzymes involved in regulating metabolism, regulation of gene expression and cellular growth are thereby modulated. A brief summary of the insulin signalling pathways is illustrated in Figure 1.3 and the known molecules participating in these pathways are described in the following sections.

1.2.2.1 Insulin Receptor Substrate-1 (IRS-1)

Insulin receptor substrate-1 (IRS-1) is a cytoplasmic protein which is widely expressed in mammalian tissues and is highly conserved among species (28). Its molecular weight is 131 kDa but it is highly phosphorylated which results in slower electrophoretic mobility during polyacrylamide gel electrophoresis (PAGE) also referred to as gel retardation (29). It thus migrates, depending on the tissue of origin, in the 160-190 kDa range.

IRS-1 is a direct substrate of the insulin receptor and its phosphorylation is decreased in intact cells expressing kinase-deficient insulin receptor mutants (30). Twenty one potential tyrosine phosphorylation sites, including six in YMXM and three in YXXM motifs (Y: tyrosine, M: methionine, X: any amino acid located C-terminal to the tyrosine) exist on IRS-1 (29,31). At least eight of the tyrosine residues on IRS-1 are phosphorylated immediately in response to

Figure 1.3 Insulin signalling pathways

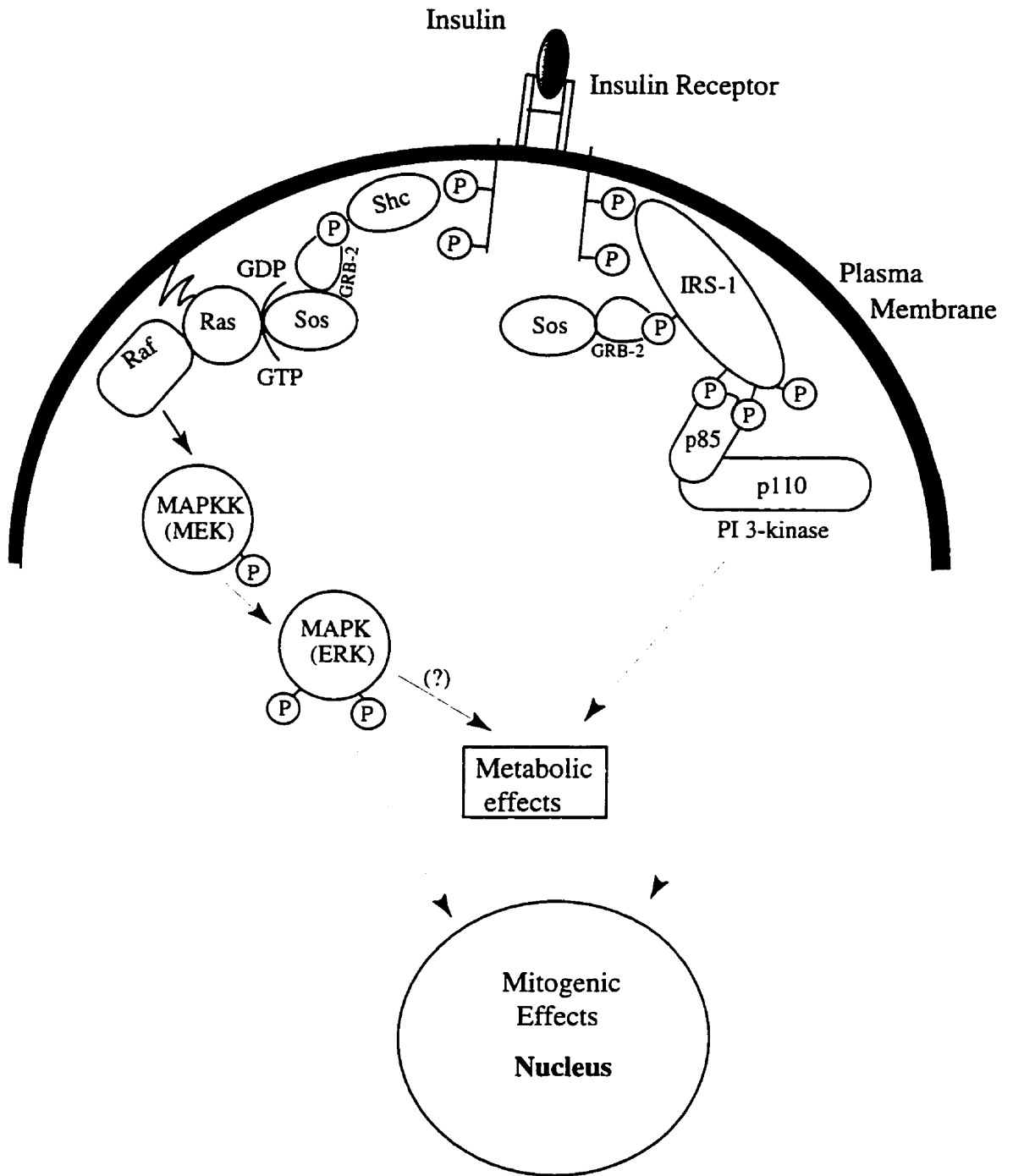

This figure represents two major pathways in insulin signalling. The PI 3-kinase and the Ras-MAPK pathway. It should be noted that the Ras-MAPK pathway can also be activated by binding of Grb2-Sos to IRS-1 (see text for more details).

insulin stimulation and these could serve as binding sites for proteins containing Src homology 2 (SH2) domains. These domains, originally identified in the oncogene v-Src, are approximately 100 amino acids long and bind phosphorylated tyrosine residues. The specificity of interaction is determined by the 3 to 5 amino acids carboxyterminal to the tyrosine (32,33). Well characterized examples of such proteins with SH2 domains include the p85 regulatory subunit of PI 3-kinase (34), and GRB2 (35). Additionally, other SH2 domain containing proteins such as the cytoplasmic Src-like kinase Fyn, the adaptor protein Nck, and the phosphotyrosine phosphatase Syp have been reported to bind to IRS-1 (4). The majority, 9 of 21 tyrosine phosphorylated sites of IRS-1 have the motif YMXM or YXXM which are specifically recognized by the p85 subunit of PI 3-kinase (see below).

Apart from the tyrosine phosphorylation sites, IRS-1 also has 40 sites for potential serine/threonine phosphorylation by protein kinase A (PKA), protein kinase C (PKC) or casein kinase II, whose physiological importance has yet to be defined (2). Several other structural motifs exist on IRS-1 whose functional importance is currently being studied. Two domains are located at the NH₂ terminus, the Phosphotyrosine Binding (PTB) domain, which binds tyrosine phosphorylated residues with specific amino acid sequence N-terminal to tyrosine, and the pleckstrin homology (PH) domain, a domain first identified in the protein pleckstrin, that might mediate protein-protein interactions. Recent studies (36) suggest that the PTB domain of IRS-1 binds phosphotyrosine 960 on the β -subunit of the insulin receptor which is in a NPEY motif located in the juxtamembrane region of the insulin receptor. The binding of PTB domain to specific tyrosine phosphorylated receptors may confer substrate specificity on various receptor tyrosine kinases. Shc also contains a PTB domain (see below). The function of the PH domain is not clear but has been implicated in mediating protein-lipid membrane interactions (37) or interactions with proteins such as the $\beta\gamma$ subunits of the heterotrimeric GTP binding (G) proteins (38).

The importance of IRS-1 in insulin signalling was examined in vivo in the IRS-1 knockout mouse. Transgenic mice with targeted disruption of the IRS-1 gene manifested retarded embryonal and postnatal growth, impaired glucose tolerance, and a decrease in

insulin/Insulin-like Growth Factor (IGF)-1-stimulated glucose uptake in vivo and in vitro, but did not develop diabetes (39). The residual insulin/IGF-1 action correlated with the appearance of a second highly homologous insulin receptor substrate (IRS-2) protein (40), which is immunologically distinct from IRS-1 and possibly plays a role in the insulin signalling pathway. The exact physiological role of IRS-2 and its differences from and similarities to IRS-1 is currently being elucidated. Studies with transgenic mice with targeted disruption of both IRS-1 and IRS-2 genes have already been initiated.

1.2.2.2 Src homology and collagen like (Shc) proteins

Other known targets of the insulin receptor apart from IRS-1 include the cytosolic 46, 52, and 66 kDa Src homology and collagen like (Shc) proteins (41,42). p46Shc and p52Shc are ubiquitously expressed and both are encoded from the same mRNA transcript by alternate translational initiation sites. They thus differ in the extent of the amino-terminal sequence. p66Shc is likely derived from a distinct transcript. The three Shc proteins contain a carboxyl-terminal SH2 domain, a central glycine/proline-rich region homologous to the $\alpha 1$ chain of collagen (41), and like IRS-1, a PID (for phosphotyrosine-interacting domain) or PTB domain in its aminoterminal region (36).

Shc acts similarly to IRS-1 as a docking molecule linking the insulin and IGF -I receptors to downstream signalling pathways. Upon insulin stimulation Shc (p46Shc and p52Shc) is rapidly phosphorylated on tyrosine and serine residues (43). The tyrosine phosphorylated residues of Shc act as docking sites for the SH2 domain-containing protein Grb2 (44). Therefore Shc plays a role linking insulin receptor activation to the Ras-MAPK activation (see below). Recently it has been shown that Shc interacts with the insulin receptor via a mechanism that involves the PTB domain of Shc and the NPEY motif of the insulin receptor (36).

1.2.2.3 Grb2 -associated binder 1 (Gab-1) and p60

Very recently, using a recombinant GRB2 a complementary DNA called Gab1 for Grb2 -associated binder 1 was isolated (26). Gab1 is a substrate of the EGF and insulin receptor and has amino acid homology and structural similarities with IRS-1. Similar to IRS-1 it can act as a docking protein for several SH2-containing proteins such as Grb-2, PI3-kinase, and PLC- γ . Overexpression of Gab1 enhances cell growth and results in transformation indicating that this protein plays a role in insulin receptor signalling. However its exact functional importance and role in metabolic versus mitogenic effects remains to be clarified.

Another molecule that has been identified very recently to be tyrosine phosphorylated upon insulin stimulation is the 60 KDa protein p60. The p60 molecule associates with the p85 subunit of PI 3-kinase and with Syp in an IRS-1 independent manner and its role in insulin signalling is currently under investigation (27).

1.2.2.4 Phosphatidylinositol 3-kinase (PI 3-kinase)

1.2.2.4.1 Characterization of the enzyme

The enzyme PI 3-kinase was initially found to exist as a heterodimer consisting of a regulatory 85 kDa (p85) and a 110 kDa (p110) catalytic subunit (45). However, a family of PI 3-kinase isoforms has been identified today, some of which do not form p85-p110 heterodimers (45). Different cDNAs encoding p85 (α , β and γ) have been cloned from bovine libraries (45) and isoforms of lower molecular weight and other alternative splicing products have been identified (46). The p85 regulatory subunit of PI 3-kinase contains two SH2 domains, a Src homology 3 (SH3) domain (which is also present in the v-Src oncogene and in many cytoskeletal proteins), at least two proline rich sequences which can bind SH3 domains of other proteins, and a domain with sequence similarity to Bcr, the product of the breakpoint cluster gene (2,45). The p85 subunit does not contain any enzymatic activity but instead plays a regulatory role. In addition to its association with the p110, it associates with a number of

adaptor molecules and enzymes some of which are the PDGF receptor and insulin receptor, IRS-1 (34,47), p21^{ras} GAP and its 62 kDa associated protein (48), a 60 kDa (p60) protein (27), and the cytosolic tyrosine kinase v-Src (49,50). Binding of the p85 to IRS-1 results in activation of the p110 as well as localization of the active PI 3-kinase to specific intracellular compartments (see below). The p85 subunit therefore plays an important regulatory role by activating the catalytic component of PI 3-kinase and localizing this enzyme to specific cellular sites.

In mammalian tissues three different isoforms of the p110 catalytic subunit have been found (α , β and γ). The α and β isoforms associate with p85 subunits while the γ isoform is thought to function independently of p85 and is not activated by receptor tyrosine kinase but instead by the α or the β - γ subunits of heterotrimeric GTP binding proteins (51-53). A *Saccharomyces cerevisiae* isoform of PI 3-kinase of 100 kDa (Vps34) which is required for correct targeting of proteins to the vacuole does not associate with a p85 regulatory subunit but instead associates with a 160 kDa protein serine/threonine kinase (Vps15). A homologue of the Vps34 gene has recently been cloned from human cells and is believed to function in association with a different adaptor molecule of 150 kDa (54).

The catalytic p110 subunit of PI 3-kinase possesses a lipid kinase activity and phosphorylates inositol lipids at the D-3 position. It acts on phosphatidylinositol (PI), PI-4-monophosphate (PI4P) and PI-4,5-bisphosphate (PI4,5P₂) and converts them to PI-3-monophosphate (PI3P), PI-3,4-bisphosphate (PI3,4P₂), and PI-3,4,5-triphosphate (PI3,4,5P₃), respectively (45). The different catalytic isoforms are suggested to have distinct substrate specificity. For example, although the α , β , and γ isoforms of p110 can phosphorylate all three substrates, the yeast Vps34 gene product and its human homologue are able to phosphorylate only PI and not PI4P or PI4,5P₂. The p110 subunit is also able to interact specifically with certain signalling molecules such as the small GTP binding proteins p21^{ras} (55) and the Rho family GTPases Rac and Cdc42 (56). It has been suggested that interaction with p21^{ras} protein is important to bring the catalytic subunit into proximity of its substrates (55). The Rho family GTPases Rac and Cdc42 (56) are involved in the mediation of growth factor-induced actin

reorganization (57), and p110 interacts only with the GTP bound forms of Ras, Rac and Cdc42 (56) which may suggest that PI 3-kinase may serve as an effector of these signalling molecules.

Initial studies showed that insulin stimulates PI3-kinase activity in anti-phosphotyrosine immunoprecipitates of rat adipocytes (58), suggesting the interaction of the enzyme with the tyrosine kinase cascade initiated by the insulin receptor. Today the activation of PI 3-kinase by insulin has been established in all major insulin target tissues, (ie. muscle, fat, and liver) in vivo and in cultured cells (47,59-65). After insulin stimulation and tyrosine phosphorylation of IRS-1 the two SH2 domains of the p85 subunit bind to tyrosine phosphorylated residues of IRS-1 (Figure 1.4) in domains with the phosphorylated YMXM sequence (29). This in turn increases the activity of the catalytic p110 subunit (34,66,67) which then acts on downstream unknown targets that mediate the effects of insulin. Recent reports suggest that the p85 regulatory subunit can also associate directly with the insulin receptor (68-70). The p110 catalytic subunit of PI 3-kinase also possesses protein serine kinase activity towards itself and IRS-1 (45,71). The importance of this serine kinase activity is not known although it has been suggested that serine phosphorylation of p110 may be a mechanism to autoregulate its activity (72) while serine phosphorylation of IRS-1 may function as a negative feedback mechanism.

1.2.2.4.2 Physiological role of PI 3-kinase

Under basal conditions the D-3-phosphorylated phosphoinositides are present at low concentrations in intact cells but activation of PI 3-kinase increases their concentration rapidly and transiently. These lipid products are not substrates for any known phospholipases, suggesting that their biological activities may be mediated directly (73). It has been reported that PI3,4P and PI3,4,5P can activate some isoforms of protein kinase C (PKC) (74,75). As well the serine/threonine kinase encoded by the Akt/RAC protooncogene (also known as PKB) has also been suggested to be a target of D-3 phosphorylated inositides (76-78) (Figure 1.4). This kinase may be involved in the cell growth response mediated by PI 3-kinase activation and most recently has been implicated in the regulation of glycogen synthesis. Microinjection of a bacterial fusion protein containing the N-terminal SH2 domain of p85 inhibited insulin-stimulated DNA

Figure 1.4 PI 3-kinase signalling pathway

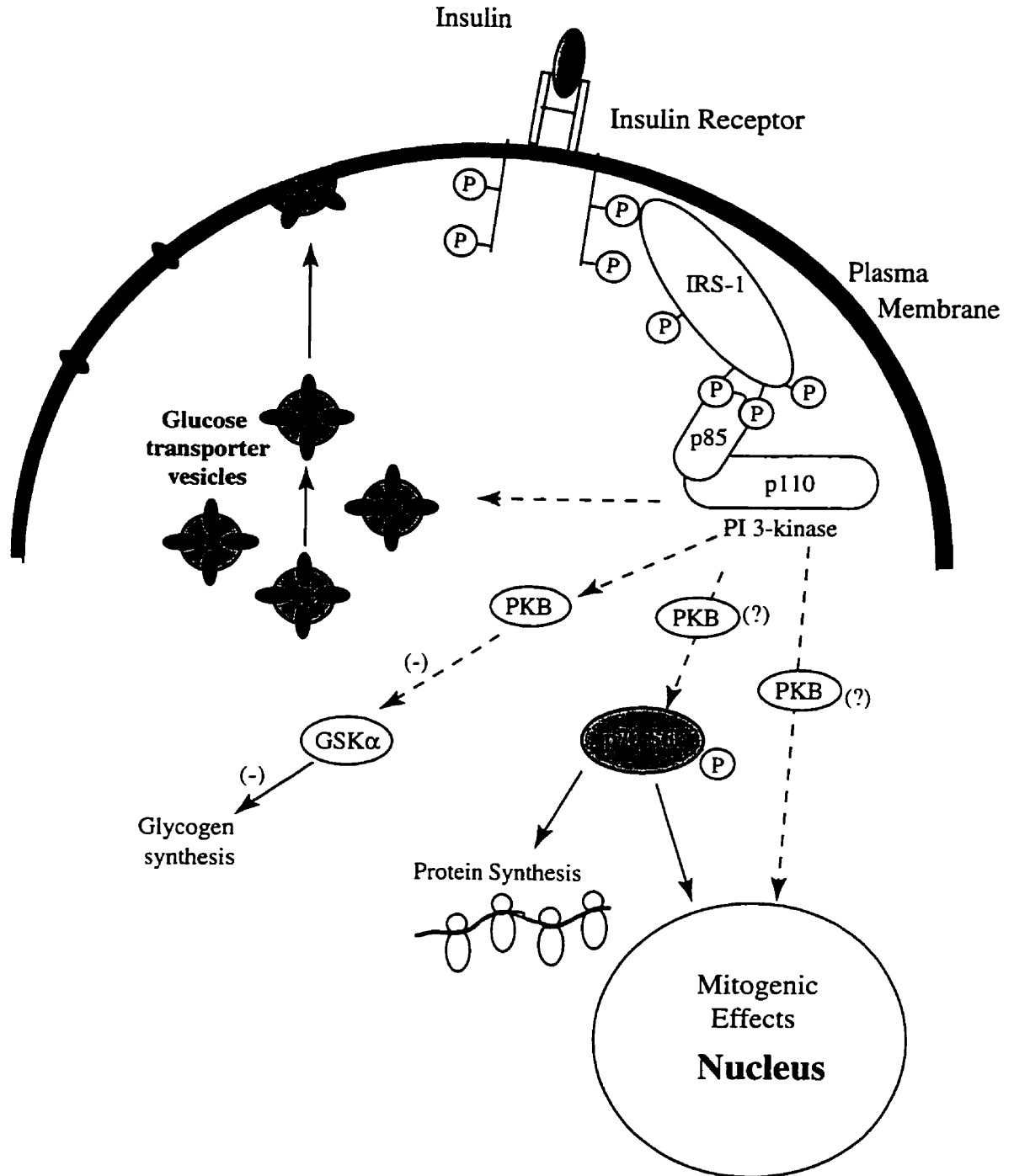

One of the major insulin signalling pathways involving PI 3-kinase is shown here. PI 3-kinase is involved in multiple insulin responses. PKB is a downstream effector of PI 3-kinase that possibly is involved in many of these responses.

synthesis (by 90%) and c-fos protein expression (by 80%) in insulin responsive fibroblasts (79) indicating that PI 3 kinase is a key and necessary component in the insulin signalling pathway leading to cell cycle progression. As well, PKB phosphorylates and inactivates GSK3 (glycogen synthase kinase) in L6 cells (80). The latter enzyme (GSK3) phosphorylates and inactivates glycogen synthase the rate-limiting enzyme in glycogen synthesis. By inactivating GSK3, PKB indirectly stimulates glycogen synthesis. Apart from these actions, the D-3 phosphorylated lipids may play a role in cytoskeletal reorganization, secretory responses and protein trafficking (61,63,64,81).

Wortmannin (82) and 2-(4-morpholinyl)-8-phenyl-4H-1-benzopyran-4-one (LY294002) (83) are two inhibitors of PI 3-kinase that have been used extensively to elucidate the involvement of this enzyme in different signalling pathways, particularly in the insulin signalling cascade. Wortmannin inhibits PI 3-kinase in a noncompetitive manner with respect to phosphatidylinositol or ATP. It binds irreversibly to the p110 catalytic subunit of PI 3-kinase (82). LY294002 behaves as a competitive inhibitor of the ATP binding site of PI 3-kinase but it does not inhibit several other ATP -requiring enzymes. A very specific binding site involving the morpholine and pyran ring of the molecule appears to be required (83). PI 3-kinase activity is inhibited in a dose-dependent manner by nanomolar concentrations of wortmannin and micromolar concentrations of LY294002 and the cellular levels of PI 3,4P₂ and PI-3,4,5P₃ are reduced by more than 95% (61,63,64,81). The insulin-stimulation of glucose uptake and recruitment of glucose transporters to the plasma membrane (61,63-65), the insulin-stimulation of DNA synthesis (79,84), and the insulin-induced reorganization of the actin network (57,81) were all blocked by the inhibition of PI 3-kinase. These data suggest that PI 3-kinase plays an important role in the above physiological events although the exact mechanism of action is not known. PI 3-kinase is also an upstream mediator of the activation of the ribosomal pp70 S6 kinase (pp70^{S6K}) by insulin (63,85-87) while it is not involved in the insulin stimulation of the Ras-MAPK cascade and pp90 S6 kinase, evident from studies with the inhibitors of p110 or transfection of mutant isoforms of p85 (63,88) (Figure 1.4). At this point the protein (enzyme) which links PI3-kinase and its metabolic products to glucose transport remain unknown.

It should be noted that wortmannin not only inhibits the lipid kinase activity but also the serine kinase activity of PI 3-kinase at nanomolar concentrations (89) and therefore this should be kept in mind when wortmannin is used in various experiments.

1.2.2.5 Ras-MAPK pathway

In addition to the insulin signalling pathways in which PI 3-kinase is a key player, another well characterized pathway exists, the Ras-MAPK pathway, which has been demonstrated to play a major role in regulation of mitogenesis and cell growth. This pathway (illustrated in Figure 1.3) is initiated by the association of the adaptor molecule Growth factor Receptor Binding protein 2 (GRB-2) with tyrosine phosphorylated IRS-1 or another adaptor molecule Shc (the Src and collagen homologous protein) leading to activation of p21^{ras} (Ras) and initiation of a complex cascade of serine/threonine kinases which leads to activation of Mitogen Activated Protein Kinase (MAPK) (44,90). Although not shown in Figure 1.3, there are evidence for crosstalk between the major insulin signalling pathways. For example, under certain conditions in some cells wortmannin, a PI3-kinase inhibitor was able to abolish MAPK activation by insulin (91).

1.2.2.5.1 Growth factor Receptor Binding protein 2 (GRB-2) and Sos

GRB-2 is a 25 kDa protein which contains one SH2 and two SH3 domains (35). GRB-2 is associated with the guanine nucleotide exchange factor of Ras called mSos (homologous to the *Drosophila* protein Son of sevenless) through its SH3 domains that bind proline rich sequences on Sos. Following insulin stimulation GRB-2 associates through its SH2 domain with the tyrosine phosphorylated IRS-1 or Shc (44). The IRS-1/GRB-2/mSos or Shc/GRB-2/mSos complex interacts with Ras which is localized at the plasma membrane and activates it by stimulating the exchange of the nucleotide bound to Ras from GDP to GTP. Translocation of Sos to the plasma membrane is a major determinant of Ras activation and this activation can be mimicked by direct targeting of Sos to the plasma membrane. Sos acts by stabilizing a

nucleotide-free intermediate of Ras. While it has been argued that the excess of GTP (approximately 20-fold) over GDP in vivo is the main driving force for the acquisition of the Ras-GTP-bound state, other studies indicate that Sos:apoRas complex has a higher affinity for Ras-GTP than Ras-GDP and therefore may assist in the formation of Ras-GTP (reviewed in (92)). Activated Ras leads to activation of a cascade of serine/threonine protein kinases leading to MAPK activation (29). Therefore GRB-2 is the adaptor molecule connecting the tyrosine kinase cascade to the Ras-MAPK pathway. Unlike PI 3-kinase, GRB-2 has no enzymatic activity (90). Both bind simultaneously to different tyrosine phosphorylated residues of IRS-1 which allows simultaneous propagation of signals through both PI 3-kinase and Ras (29). However, studies suggest that important mitogenic effects mediated by the Ras-MAPK cascade rely more on the interaction of GRB-2 with Shc than with IRS-1 (44,90).

The ability of the GRB-2/mSos complex to maintain Ras in its activated state appears to be controlled by feedback loop mechanisms. Recent studies suggest that some yet unidentified kinase, which is located downstream of Ras in the insulin signalling cascade, is able to phosphorylate mSos and cause its dissociation from GRB-2 thereby interrupting Ras activation by the activated insulin receptor (93-95).

1.2.2.5.2 Ras

p21^{ras} (Ras) is a 21 kDa protein that can bind GTP or GDP. It is active when it is in the Ras-GTP bound form and can hydrolyze GTP through an intrinsic GTPase activity. Ras was found to be activated in many tumors and was first discovered as an oncogene product (96). It is a member of a large family of small GTP binding proteins known as the *Ras* superfamily which is believed to play important roles in the signalling of many cell surface receptors including the insulin receptor. The Ras family GTP binding proteins are involved in the control of cell growth, metabolism and intracellular membrane traffic (2,97). Upon insulin stimulation, the mSos molecule which promotes the exchange of GDP for GTP on Ras and is associated with GRB-2, is brought into the vicinity of Ras as described above thereby activating it (44,98). The activation of Ras is transient, because the protein itself possesses intrinsic GTPase activity that is

also stimulated by GTPase activating proteins known as GAPs, which quickly return Ras to the GDP bound state. Furthermore, as mentioned above (see 1.2.2.5.1) Ras activation is also controlled through feedback dissociation of the GRB-2/mSos complex by downstream effectors of Ras.

Microinjection of a dominant negative mutant p21^{ras} protein (N17 Ras) or anti-Ras monoclonal antibody into rat fibroblasts overexpressing human insulin receptors resulted in reduction (75-90%) of insulin-stimulated DNA synthesis and c-fos expression (99). Overexpression of normal Ras protein in fibroblasts increases the expression of the insulin-stimulated transcription genes c-fos and c-jun (100). These results suggest that Ras is an important intermediate signalling molecule in the insulin signal transduction pathway and is required for gene expression and DNA synthesis.

1.2.2.5.3 The Raf kinase

Raf is a kinase which is located downstream of Ras in the Ras-MAPK signalling pathway. It is the product of another oncogene encoding a cytoplasmic serine/threonine kinase (101). Ras-GTP binds directly to and localizes Raf to the plasma membrane (101-103). Once at the plasma membrane Raf becomes activated by a still unknown mechanism which may involve phosphorylation by the Src tyrosine kinase, also located in this compartment, interaction with lipids and/or interaction with unidentified proteins. However, since Raf activation requires phosphorylation of the protein (101) it is suggested that some protein kinase activity may be involved in the activation of Raf. The downstream target of activated Raf is the serine/threonine kinase MAPK kinase, known as MEK, (MAPKK or ERK (extracellular signal regulated kinase) kinase) (see below), which phosphorylates and activates the MAPKs (Erk1 and 2) (Figure 1.3).

1.2.2.5.4 MAPKK or ERK kinase (MEK) and mitogen-activated protein kinase (MAPK)

MEK is a dual specificity kinase which can phosphorylate both threonine and tyrosine residues. Upon its phosphorylation and activation by Raf, MEK phosphorylates the serine/threonine kinases MAPKs on threonine and tyrosine residues, thereby activating their enzymatic activity. Two isoforms of MAPK also known as extracellular signal regulated kinase (Erk) 1 and 2, are about 44 and 42 kDa respectively (43). Both tyrosine and threonine phosphorylation are required for Erk activation (104). The Erk or MAPK family of protein serine/threonine kinases regulates the so called immediate early genes which are subsequently involved in the transcriptional regulation of specific genes in the nucleus that are responsible for cell growth and proliferation (105). Erks mediate changes in nuclear protein transcription by phosphorylating and activating c-Fos, c-Jun and c-Myc in response to stimulation by a variety of growth factors (106). An antisense strategy that depleted the p42 and p44 Erks resulted in an inability of serum in 3T3-L1 fibroblasts and insulin in adipocytes to stimulate DNA synthesis. These experiments also showed that insulin-activation of the 90 kDa ribosomal S6 kinase (p90 S6k), also known as p90^{rsk}, was also blocked (107) by antisense Erk, suggesting that Erk activity is required for insulin stimulation of DNA synthesis and p90^{rsk} activation.

Apart from the effect of MAPKs on mitogenesis which is well studied, MAPKs have a more widespread action. MAPKs are upstream of the serine/threonine kinase known as p90^{rsk}. Activated p90^{rsk} may contribute to stimulation of glycogen synthesis in response to insulin (2). Activated p90^{rsk} phosphorylates and activates the glycogen-associated protein phosphatase-1 (PPG-1) and also phosphorylates and inhibits the glycogen synthase kinase 3 (GSK3) (108). Activation of PPG1 and inhibition of GSK3 both result in decrease of glycogen synthase phosphorylation. Phosphorylation of glycogen synthase inhibits its enzymatic activity and therefore inhibition of its phosphorylation results in an increase of its activity and potentiation of glycogen synthesis. However more recent studies suggest that in intact rat skeletal muscle activation of MAPK by insulin is neither necessary nor sufficient for the activation of glycogen

synthase and that possibly a rapamycin (an inhibitor of pp70 S6 kinase)-sensitive mechanism may be involved (109).

It is clear from this review that there is still a great deal of information lacking in our knowledge of the mechanism and regulation of insulin action. Other signalling molecules have been identified for which a clear function has not been determined e.g. Nck, SHP2/Syp, and still others remain to be identified. In particular the events and molecular components linking PI 3-kinase and/or MAPK to the final metabolic and mitogenic changes induced by insulin requires further elucidation.

1.3 GLUCOSE TRANSPORT AND GLUCOSE TRANSPORTERS

There are two different families of proteins that transport glucose into mammalian cells (110). One family is that of proteins which cotransport Na^+ and glucose (the Na^+ /glucose cotransporter) which are present in the intestine and the kidney. These proteins transport glucose and galactose against their concentration gradient, and as Na^+ moves into the cell due to an electrochemical gradient across the plasma membrane glucose is transported as well. The energy used for this process (secondary active transport) comes indirectly from the ATP hydrolysis by the Na^+/K^+ ATPase which works to maintain the Na^+ gradient. Indirect evidence indicates that the Na^+ to sugar coupling ratio is 2. The kinetics of the Na^+ /glucose cotransporter are ordered; i.e., Na^+ binds first to change the conformation of the protein to allow sugar binding (the affinity for sugar increases when the external Na^+ is increased) (reviewed in (111)). The other family is that of the facilitative glucose transporters which transport glucose in an energy independent manner down its concentration gradient. Glucose transport through the facilitative glucose transporters was studied in this thesis and therefore this family of transporters will be described in more detail in the next section.

1.3.1 Facilitative glucose transporters

1.3.1.1 The transporter family

Facilitative glucose transporters (GLUTs) are a family of transmembrane proteins. Six different genes coding for facilitative glucose transporters and one pseudogene, which does not encode a protein, have been identified up to now and are designated GLUT1 to GLUT7 according to the order of their discovery (for reviews see (112-115)). Although every one of these facilitative GLUT isoforms is encoded by a different gene all isoforms are structurally related. All GLUT proteins are 45-55 kDa and based on the sequence analysis it has been proposed (116) that the GLUT protein spans the membrane 12 times by α -helical loops, has an exofacial loop bearing a single *N*-linked glycosylation site, and a middle cytoplasmic loop with both the NH₂- and COOH-terminal domains located intracellularly. The current model of a generic glucose transporter is shown in Figure 1.5. The hydrophobic regions that span the membrane have the highest sequence homology among the different isoforms and these may encode the sugar transport function (115). The cytoplasmic loop, the amino and the carboxyl termini have considerable differences in their sequence among the different isoforms and these are used for the production of isoform-specific antibodies usually raised against the last 12 or more amino acids of the COOH-terminal domains (117).

The exact glucose binding site on the facilitative glucose transporters has not been mapped and the exact mechanism by which glucose is transported through the plasma membrane is not known. It is thought that the transporters contain a specific glucose binding site that can exist in two different conformations, one facing outward and the other inward (for review see (110)). The transporter binds the glucose molecule when it is in the outward facing conformation. This binding triggers a conformational change that causes the glucose binding site to face inward and finally release glucose intracellularly. It should be mentioned that glucose transport through the facilitative glucose transporters (GLUTs) is stereoselective, saturable and bidirectional (110).

Figure 1.5 Structure of the facilitative glucose transporters

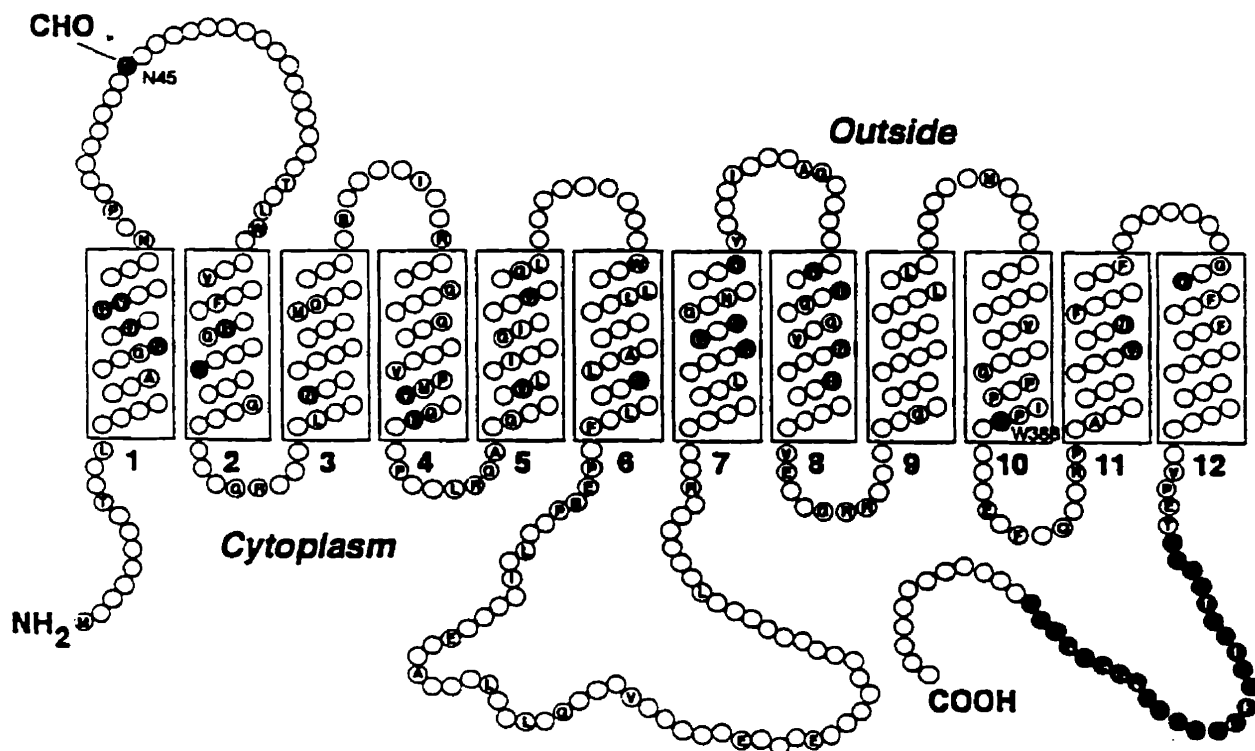

Facilitative glucose transporters span the plasma membrane twelve times. The transmembrane helices are shown as boxes and are numbered 1-12 (regions in boxes). The different loops formed and the amino- and carboxy-terminus are also shown. In the extracellular loop connecting transmembrane segments 1 and 2 exists the N- glycosylation site. Invariant amino acid residues are denoted by a single-letter abbreviation and the amino acids that are critical for transporter function are noted in black.

1.3.1.2 Biochemical properties and tissue distribution of glucose transporters

From the seven different GLUT genes identified, GLUT6 is a pseudogene and does not encode a functional protein. The protein products of all the other genes have been identified and sequenced.

Although facilitative glucose transporters have large sequence homology and structural similarity, they have several functional differences due to their different tissue distribution, cellular localization, transport kinetics and sugar specificity.

1.3.1.2.1 GLUT1

The GLUT1 glucose transporter isoform is abundantly expressed in red blood cells and in brain microvessels. It is also expressed at variable levels in almost all tissues in mammals and it is suggested that it may be responsible for constitutive or basal glucose uptake (112). The K_m of GLUT1 is about 6-7 mM for 2-deoxyglucose (110,112) suggesting that at the physiological circulating concentrations of glucose (4-6 mM) GLUT1 is not saturated.

1.3.1.2.2 GLUT2

The GLUT2 facilitative glucose transporter is expressed in the basolateral membranes of small intestine and kidney (118), liver and β -cells of the pancreas (119). In liver cells GLUT2 transports glucose into the cells when the blood glucose is high such as in the fed state but when the blood glucose is low during fasting GLUT2 transports glucose out of the cells (113). GLUT2 has the highest K_m value for glucose (12-16 mM for 2-deoxyglucose and 42 mM for 3-O-Methylglucose) compared to all other isoforms (110). This transporter then is always unsaturated under physiological conditions. Because of these kinetic properties of GLUT2 and the fact that glucokinase has a K_m for glucose of 6 mM the rate of glucose metabolism in β -cells is controlled by glucokinase (113). GLUT2 and glucokinase are thought to comprise the glucose sensing unit of the β -cell because of the similarities of the K_m s and their sequential sites in the handling of glucose.

1.3.1.2.3 GLUT3

Screening a human fetal muscle cDNA library resulted in cloning of the GLUT3 facilitative glucose transporter (120). GLUT3 mRNA predominates in the neuronal and glial cells of the brain in rodents and is detectable in a variety of human tissues (112). The GLUT3 protein has been detected in rat fetal and regenerating muscle (121) as well as in L6 cultured rat skeletal muscle, where it is believed to play an important role in glucose transport in these tissues. The K_m values of GLUT3 are lower than those of GLUT1, i.e., 1-2 mM for 2-deoxyglucose as measured in *Xenopus* oocytes microinjected with GLUT3 cDNA.

1.3.1.2.4 GLUT4

The GLUT4 transporter is expressed in peripheral tissues that respond to insulin with an increase in glucose transport such as cardiac and skeletal muscles and white and brown adipose tissue and thus has been named the "insulin-sensitive" glucose transporter (122-124). The reported K_m values for GLUT4 are 5 mM for D-glucose, and 4-5 mM for 2-deoxyglucose (112,125,126), suggesting that it is only half-saturated under euglycemic conditions. In muscle and fat cells under basal conditions GLUT4 is localized mainly intracellularly. Insulin rapidly redistributes GLUT4 to the cell surface contributing to the increase in glucose transport (117,124,127,128).

1.3.1.2.5 GLUT5

The GLUT5 glucose transporter mRNA and protein is found on the luminal (112) and basolateral site of intestinal epithelial cells suggesting that this transporter may facilitate the transport of hexose across the enterocyte (129). In addition, GLUT5 mRNA (130) and GLUT5 protein are found in human skeletal muscle and fat cells (131,132). It is thought that GLUT5 may, similar to GLUT1, facilitate basal hexose transport into muscle cells since subcellular

fractionation and immunocytochemistry studies detected it at the plasma membranes of human muscle and fat cells, and these levels were not altered by insulin treatment.

It is likely that GLUT5 transports fructose. Evidence supporting this possibility comes from studies where microinjection of GLUT5 mRNA into oocytes resulted in the increased uptake of fructose (with a K_m of 6 mM) but not of 2-deoxyglucose (133). Additionally in human skeletal muscle membranes it was shown that cytochalasin B binding (which binds to GLUTs) was protected to some degree by D-fructose (131) and human skeletal muscle has been shown to take up fructose from the blood (134).

1.3.1.2.6 GLUT6

The GLUT6 cDNA was cloned from a human jejunum library and found to have 80% identity to that of GLUT3 (130). The GLUT6 mRNA is detected in many human tissues. However, the GLUT6 gene cannot encode a functional glucose transporter protein because of the existence of multiple stop codons and frame shifts and therefore it has been designated as a pseudogene.

1.3.1.2.7 GLUT7

GLUT7 has been isolated from a liver cDNA expression library (135) The GLUT7 protein is retained in endoplasmic reticulum via a consensus retention signal present within its COOH-terminal tail. However, the exact functional role of this protein is not known. It seems however that it may mediate release of glucose from the endoplasmic reticulum participating in hepatic glucose production as part of the glucose-6-phosphatase complex. Evidence for this function come from studies where the antibody against GLUT7 inhibited glucose-6-phosphatase activity (the enzyme involved in gluconeogenesis) in intact liver microsomes and blocked glucose exit from the microsomes (135). Additionally, glucose transport across the membrane of microsomes prepared from cells transfected with GLUT7 was sustained while phloretin (135) an inhibitor of facilitative glucose transporter inhibited it.

1.3.1.3 Cellular localization of glucose transporters

Early observations showed that the facilitative glucose transporters were present in plasma membranes as well as in membranes of intracellular origin and that after insulin treatment of adipocytes the binding sites for cytochalasin B, a fungal alkaloid that crosses the plasma membrane and binds to glucose transporters in their inward facing conformation, were increased in the plasma membranes (136-138). These observations stimulated the interest of investigators and many studies have been performed examining the subcellular localization of the GLUT proteins and more specifically, the insulin responsive isoform GLUT4 (for review see (139)). Cloning of the different transporter isoforms and development of isoform specific antibodies had an enormous impact on these studies. Today, it has been well established that in the basal state in skeletal muscle and fat cells the GLUT1 is mainly localized at the plasma membrane while the insulin-responsive isoform GLUT4 is localized mostly in intracellular compartments (139,140). This localization of the GLUT4 isoform enables it to respond to insulin acutely and contribute to the regulation of glucose transport in muscle and fat.

1.3.2 Regulation of glucose transport

Glucose transport into cells can be regulated acutely and chronically. Acute or short term regulation takes place by mechanisms resulting in rapid changes of glucose transporter number present at the cell surface and/or changes in their intrinsic activity. Chronic or long term regulation involves mechanisms resulting in changes of glucose transporter levels due to alterations in transporter synthesis and/or degradation.

1.3.2.1 Long term regulation of glucose transport and transporter expression

Long term regulation of glucose transport can be achieved by altering the amount of available facilitative glucose transporters in the cell by affecting i) the rate of synthesis of transporter proteins via alterations in transcription and/or translation, ii) the rate of their

degradation which determines their life span. It is important to understand the mechanisms involved in the long term regulation of glucose transporters because they play an important role in glucose homeostasis in the body and therefore they may be involved in the pathophysiology of diabetes (141-143).

Cells in culture such as 3T3-L1 adipocytes and L6 myotubes, discussed later, are particularly well suited for studying chronic regulation of glucose transport as they remain stable for relatively long periods of time. In L6 and 3T3-L1 cells glucose transport and the glucose transporter levels can be regulated by growth factors such as insulin and IGF-I, glucose and other pharmacological and environmental factors such as drugs used in the management of diabetes and hypoxia respectively.

1.3.2.2 Short term regulation of glucose transport

Glucose transport into muscle and fat tissue can be regulated acutely by growth factors (i.e. insulin and IGF-I), exercise or contraction, various pharmacological agents (e.g. protein tyrosine phosphatase inhibitors(PTPs)) and environmental factors such as starvation or hypoxia. Changes in the rate of glucose transport can be brought about rapidly by i) changes in the number of glucose transporter proteins present at the cell surface, seen as changes in V_{max} , ii) changes in the affinity of transporter proteins for glucose, seen as changes in K_m , and iii) changes in the intrinsic activity of transporters (i.e. V_{max} divided by K_m) known also as kinetic turnover number or transport capacity .

In skeletal muscle, L6 muscle cells, adipose tissue and 3T3-L1 adipocytes insulin stimulates glucose transport rapidly. This effect of the hormone is achieved through the recruitment of glucose transporter proteins from an intracellular location to the plasma membrane. The translocation of glucose transporters particularly of GLUT4 is a well established phenomenon and it has been demonstrated to occur by a number of different techniques. Therefore, subcellular fractionation combined with cytochalasin B (which binds to all glucose transporters) binding (127,136,138), immunoblotting using specific antibodies (144), electron microscopy (128,145) and photolabelling of the cell surface glucose transporters with radioactive

TAB-BMPA, a compound that binds to the cell surface glucose transporters only, (146,147) all showed an increase in glucose transporter levels at the cell surface in response to insulin.

GLUT4 is not the only transporter that is translocated (ie recruited) to plasma membrane in response to insulin. Apart from GLUT4, the transporters GLUT1 and GLUT3, in L6 myotubes, and GLUT1 in 3T3-L1 adipocytes, CHO and BC3H1 cells are recruited in response to insulin. The ability of a certain transporter isoform to translocate in response to insulin is not a property of the transporter itself but rather a characteristic determined by the tissue in which the transporter is expressed (148).

The intrinsic activity of glucose transporters can be examined by measuring both glucose transport rates and transporter number in the same preparation. When the measured changes in the rates of glucose transport are not paralleled by equal changes in glucose transporter proteins present in the plasma membrane (usually detected by cytochalasin B binding) it is suggested that the intrinsic activity of the transporters changes. Although most studies today reveal no alteration of K_m value of the glucose transporter for its substrate in response to insulin, some studies suggest that insulin has a dual effect on the skeletal muscle cell surface transporters, increasing both the glucose transporter number and the transporter turnover rate (149). However neither the mechanism of regulation nor the functional importance of glucose transporter intrinsic activity is known.

1.3.2.3 Intracellular traffic of glucose transporters

The mechanisms involved in the intracellular traffic of glucose transporters has been the focus of many studies. Two proposed models which are well supported by experimental evidence are: i) regulated secretion; and ii) constant transporter recycling. According to the first model glucose transporters move from an intracellular site to the plasma membrane by mechanisms similar to those involved in the movement of vesicles in the regulated exocytic pathway. This is supported by studies where transfected GLUT4 glucose transporters in neuroendocrine PC12 cells were targeted to the secretory granules (150) and the fact that GLUT4

in adipocytes is found to be colocalized with the vesicle proteins VAMP-2 and cellubrevin which are involved in the fusion of these vesicles with the plasma membrane (151,152).

According to the second model glucose transporters move between the plasma membrane and endosomal compartments in a way similar to the constitutive endocytic pathway involved in receptor recycling. Clathrin-coated vesicles, containing the transporters are formed at the plasma membrane, which are then uncoated and incorporated into endosomes and subsequently, the endosome-derived vesicles recycle back to the plasma membrane. Evidence in support of this model comes from studies showing that GLUT4 transporters can be detected in clathrin coated vesicles and early endosomes of white (153) and brown (154) adipocytes, using immunocytochemistry techniques. Also disruption of the clathrin coat by low K^+ causes accumulation of GLUT4 transporters at the cell surface (155). These observations suggest that GLUT4 continuously recycles to and from the cell surface. It has been shown that insulin increases the rate of appearance of GLUT4 glucose transporters at the cell surface (156,157), and reduces their rate of endocytosis (158,159). The two models of glucose transporter translocation are not mutually exclusive and it could be that vesicles following a regulatory secretory pathway are internalized via recycling endosomes.

1.3.2.4 Cellular components involved in the regulation of glucose transport

1.3.2.4.1 Signalling molecules involved in insulin-stimulation of glucose transport

1.3.2.4.1.1 Role of PI 3-kinase

Several lines of evidence implicate PI3-kinase in the mediation of insulin's metabolic effects and more specifically glucose transport.

a) Inhibition of PI 3-kinase by wortmannin and LY294002 leads to a blockade in insulin-stimulated glucose transport and glucose transporter translocation in muscle (160,161) and adipose cells (162) b) Microinjection of a dominant negative mutant of the p85 regulatory subunit of PI 3-kinase, which lacks a binding site for the catalytic p10 subunit into 3T3 L1 adipocytes inhibited glucose transport and GLUT 4 translocation induced by insulin while the wild type

protein had no effect (88,162). c) The effect of insulin on PI 3-kinase is reduced in states of insulin resistance associated with defects in glucose transport. For example in the ob/ob mouse IRS-1 associated PI 3-kinase activity in muscle and liver was reduced by 90 %. Insulin-stimulated total PI 3-kinase activity was also not increased in both tissues of the ob/ob mouse (163). In obese insulin-resistant (induced by goldthioglucose injection) mice the antiphosphotyrosine associated PI 3-kinase activity in muscle tissue in response to insulin was decreased by 40-60 % and starvation of the animals for 48 h restored it to normal levels suggesting an acquired reversible defect (164).

Importantly, although PI 3 kinase appears to be critical for insulin-stimulated glucose transport, other stimuli such as contractile activity and hypoxia both increase glucose transport and glucose transporter translocation (160) in muscle, yet they do not increase the levels of the PI 3-kinase products PI 3,4 P2 and PI 3,4,5 P3 (60). Moreover the response of muscle to these stimuli is not blocked by wortmannin (60,160) suggesting that PI 3-kinase activity is not required for stimulation of glucose transport by hypoxia and contraction. The tumor promoting agent (TPA) and okadaic acid both stimulate glucose transport in rat soleus muscle and human adipocytes (165) without changing PI 3-kinase activity (161). In accordance with this wortmannin (1 μ M) did not affect the response of muscle to TPA or OA while it abolished the response to insulin (161). In L6 muscle cells the mitochondrial uncoupling agent dinitrophenol (DNP) has similar effects to hypoxia and increases glucose transport. The response of the cells is also independent of PI 3-kinase (81). All these data indicate that at least two signalling pathways exist leading to glucose transport activation in muscle with different sensitivities to wortmannin. Evidence supporting this concept come from studies showing that i) different GLUTs are recruited in response to different stimuli, (e.g. insulin and DNP), and ii) the response of cells to DNP does not require an intact actin network (81). A second concept to emerge from recent studies is that an increase in PI 3-kinase activity is not sufficient to stimulate glucose transport. Stimulation of cells with PDGF or interleukin (IL)-4 increases PI 3-kinase activity via IRS-1-independent or IRS-1-dependent pathway respectively without affecting glucose transport (166). However this issue remains controversial. Recently, it has been reported that transient

expression of a constitutively active p 110 of PI 3-kinase into 3T3-L1 adipocytes increases GLUT4 glucose transporter translocation (167) suggesting that excess PI 3-kinase activity is sufficient to increase glucose transporter translocation and glucose transport. It is possible that the response of the cells depends on the isoform of PI 3-kinase that is activated and/ or the intracellular localization of PI 3-kinase. There are also data (67) suggesting that PI 3-kinase is associated with IRS-1 in internal membranes in adipocytes after insulin stimulation.

1.3.2.4.1.2 Role of Ras

The role of p21^{ras} protein in the insulin stimulation of glucose transport has been examined in various studies. Microinjection of a constitutively active p21^{ras} protein into 3T3-L1 adipocytes stimulated the expression of GLUT 1 glucose transporter in the absence of insulin (168). Also the insulin-induced expression of GLUT 1 was blocked by a dominant negative form of p21^{ras} protein or antibodies directed against p21^{ras} protein. The above suggest that p21^{ras} mediates the insulin-induced GLUT1 expression in 3T3-L1 adipocytes. However introduction of inhibitory or activating form of p21^{ras} into adipocytes had no effect on translocation of GLUT4 glucose transporter indicating that p21^{ras} protein is not involved in the acute translocation of this protein that leads to increased glucose transport (168). Furthermore the observation that other stimuli such as growth factors (EGF) and thrombin activate p21^{ras} with a time course similar to that of insulin but do not stimulate glucose uptake in 3T3L1 (169) adipocytes suggests that p21^{ras} activation alone is not sufficient to induce acute insulin-mediated glucose transport.

The role of Ras protein on the acute insulin actions on glucose transport was tested in another study where activated mutant (Lys-61) N-Ras was overexpressed in rat 3T3-L1 fibroblasts and adipocytes (170). These cells showed an increase in basal glucose uptake (3 fold) and insulin did not stimulate it further and above this levels. The increase in glucose transport was associated with an increase in the GLUT1 and GLUT4 levels at the plasma membrane relative to the intracellular membranes without any changes in the total levels of the two transporter isoforms suggesting that Ras mimics the action of insulin on membrane trafficking of

glucose transporters suggesting that it is an intermediate in this insulin signalling pathway. Additionally more recently it has been shown that transient overexpression of the same constitutively active (Lys-61) Ras in rat adipocytes resulted in high levels of cell surface GLUT4 in the absence of insulin that were comparable to levels seen in control cells treated with a maximally stimulating dose of insulin suggesting that activated Ras is sufficient to recruit GLUT4 to the cell surface (171). However wortmannin treatment resulted in only small reduction of cell surface GLUT4 levels in cells overexpressing active Ras in contrast to the effect of wortmannin on insulin-stimulated GLUT4 plasma levels, indicating that Ras recruits GLUT4 to the cell surface by a different mechanism that is probably not involved in the insulin-stimulated GLUT4 translocation in physiological target tissues (171).

Therefore, it is obvious from the above mentioned studies that the exact role of Ras and whether it is involved in the acute action of insulin to increase glucose transport is not clear.

1.3.2.4.1.3 Role of Raf

The importance of Raf in insulin signalling cascade is evident by studies where a gene encoding an oncogenically activated Raf mutant was introduced into 3T3-L1 fibroblasts (172). Similarly to the studies with p 21^{ras} in these cells basal glucose transport was increased as well as GLUT1 transporter levels. This effect was similar to chronic insulin stimulation and reinforces the concept that chronic regulation of GLUT1 expression by insulin is mediated via this pathway. The expression and cellular distribution of GLUT4 transporter was not affected by the Raf mutant indicating that activation of Raf is not sufficient for GLUT4 translocation .

1.3.2.4.1.4 Role of MAPK

The importance of MAPK activation in the regulation of glucose metabolism was investigated by comparing the effects of insulin and EGF on MAPK activation, glucose transport and glycogen synthesis in 3T3L1 adipocytes. Although EGFR activation also results in an increase in MAPK activation, the metabolic effects including glycogen synthase activity (173),

glucose transport (169,174) and GLUT 4 translocation (173) were not increased suggesting that MAPK activation is not involved or is not sufficient for the activation of these events. Similarly, activation of pp90-ribosomal S6 kinase (pp90^{rsk}) by EGFR signalling does not lead to stimulation of glucose transport and glycogen synthesis suggesting that activation of pp90^{rsk} is not sufficient to signal these events (174).

1.3.2.4.2 Protein Kinase C (PKC)

The PKC family of protein serine/threonine kinases continues to grow and PKCs are involved in many cellular responses. At the present time, twelve different PKC isoforms have been identified and are classified based on their structural characteristics and regulation of their activities by different cofactors (175). The different classes of PKC isoforms include i) the conventional isoforms α , β I, β II and γ , ii) the novel isoforms δ , ϵ , η (L), θ and μ and iii) the atypical isoforms ζ , ι and λ (Figure 1.6).

Four conserved regions (C1-C4) are observed in the conventional PKCs (for reviews see (175,176). C1 contains a cysteine rich motif and forms the diacylglycerol binding site. C2 is the phospholipid recognition domain and also contains the Ca^{2+} sensitive portion of the enzymes (in the conventional class of isoforms). In the C3 domain is the ATP binding site and the catalytic activity of the enzyme while the C4 region is required for recognition of the substrate. The structures of the novel and the atypical classes of PKCs differ from that of the conventional isoforms. The novel class of PKCs contains a C2 like domain that does not bind Ca^{2+} . The atypical PKCs lack the C1 domain and contain only a cysteine-rich domain that does not bind diacylglycerol. The C2 domain is also not present in these isoforms. All classes maintain the catalytic (C3) and the substrate recognition (C4) domains (Figure 1.6).

Figure 1.6 Isoforms of PKC

Conventional isoforms: α , β -I, β II, γ

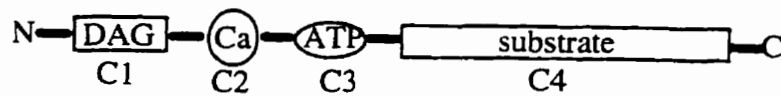

Novel isoforms: δ , ϵ , η (L), θ , μ

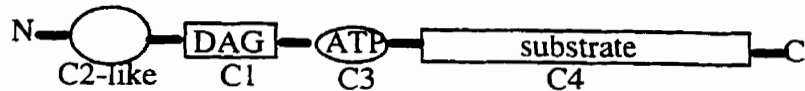

Atypical isoforms: ζ , ι , λ

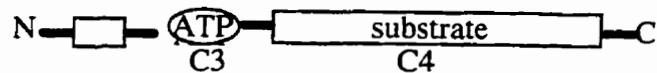

Three main different classes of PKCs have been identified with somewhat different structures. The structure and the members of each class of PKCs are depicted in this figure.

1.3.2.4.2.1 Activation of PKC

PKCs have many cellular effects including receptor desensitization, modulation of membrane structure and of immune responses, regulation of cell growth and transcription (175), as well as various transport processes including that for glucose (177-182). PKCs can be activated by a variety of stimuli. For their activation phosphatidylserine is required by all isoforms (175,176), while the requirement for Ca^{2+} and diacylglycerol depends on the isoform of PKC. Conventional PKCs require both DAG and Ca^{2+} , the novel isoforms are Ca^{2+} independent while the atypical ones do not require DAG or Ca^{2+} . G-protein coupled receptors, receptor tyrosine kinases and non-receptor tyrosine kinases, all can lead to the production of diacylglycerol either rapidly by the activation of specific phospholipase C or more slowly by the activation of phospholipase D (175,176). Also, activation of non-selective phospholipase A2 and production of *cis* unsaturated fatty acids from phospholipids can activate certain PKC isoforms (176). Many different receptor- and non-receptor-activated signalling cascades therefore can lead to the regulation of PKC activity. Phorbol esters which are potent tumor promoters strongly stimulate the activity of PKCs (the conventional and novel isoforms) and have been used widely to dissect their exact functions (175,176). They resemble structurally and functionally diacylglycerol but they have a prolonged action because are more slowly metabolized.

It is believed that unstimulated PKC enzymes are localized to the cytosol and upon activation are redistributed to the membrane. One of the best studied mechanisms for leading to activation of PKCs is that involving phospholipase C (PLC). Activated PLC breaks down phosphatidylinositol 4,5-bisphosphate (PI4,5P_2) into diacylglycerol and inositol 1,4,5-triphosphate (IP_3). IP_3 stimulates the release of Ca^{2+} from intracellular stores and the Ca^{2+} together with the produced diacylglycerol activate the PKCs. Secondly, opening of plasma membrane Ca^{2+} channels by various stimuli which increase the intracellular Ca^{2+} levels can lead to activation of PKCs. The mechanisms of PKC activation described above is shown in Figure 1.7. Diacylglycerol and Ca^{2+} each one alone and also synergistically can induce membrane association of PKC (175). Diacylglycerol increases the affinity of conventional PKCs for Ca^{2+} and therefore PKCs can be activated at low (in the micromolar range) concentrations of the ion

Figure 1.7 Activation of PKC

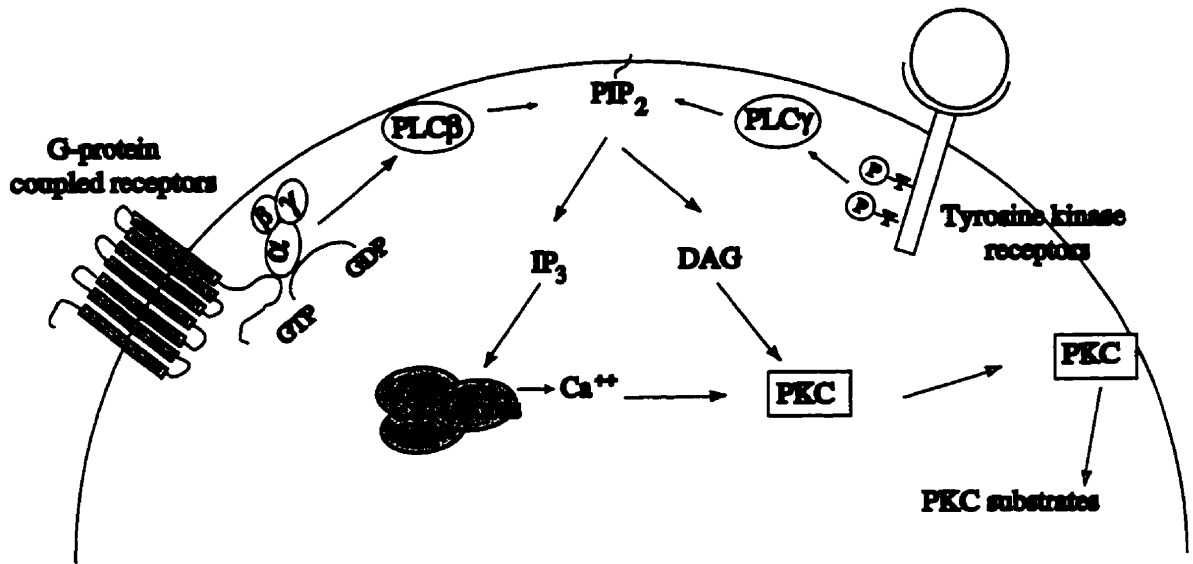

Seven transmembrane receptors as well as tyrosine kinase receptors can lead to activation of PLC and generation of DAG and IP₃. DAG together with Ca⁺⁺ released from intracellular stores by the action of IP₃ increase the activity of PKC which then can act on downstream cellular effectors.

(175,176). Diacylglycerol produced in membranes or phorbol esters added exogenously serve as hydrophobic anchors to recruit PKC to the membrane and increase the activity of the enzyme. Once in the membrane PKCs interact with phosphatidylserine and become activated (175).

An autoinhibitory pseudosubstrate sequence is present in all classes of PKCs which is believed to interact with the catalytic site and inhibit the activity of the enzyme. Binding of C1 and C2 ligands to PKC and interaction with the membrane removes the pseudosubstrate portion of the enzyme from the catalytic site and thereby potentiates its catalytic activity (175). Novel PKCs which have no Ca^{2+} binding site in their C2-like domain can function in a Ca^{2+} independent manner. Diacylglycerol alone can induce membrane association of these isoforms. Additionally, when PKCs are in the plasma membrane they can be activated in the absence of Ca^{2+} via their interaction with phosphatidylserine or other phospholipids. It is not clear how the atypical class of PKCs (which lack both the diacylglycerol and Ca^{2+} binding domain) becomes activated but recent data (74) suggest that the products of PI 3-kinase may be able to activate the ζ isoform of this class.

1.3.2.4.2.2 Involvement of PKC in glucose transport

The question of whether PKC is involved in insulin action and more specifically in the mechanism of stimulation of glucose transport by insulin was raised some years ago. Even today the answer to this question remains controversial. A number of studies suggested that insulin increases diacylglycerol levels and activates PKC in skeletal muscle and adipocytes (180,181). Also pharmacological inhibitors of PKC inhibited insulin stimulation of glucose transport (179-181,183), and it was proposed that PKC may be involved in the mechanism of stimulation of glucose transport. However, in other studies an increase in PKC activity and plasma membrane translocation of PKC in skeletal and cardiac muscle cells were not detected with insulin stimulation (177,182) suggesting that PKC is not involved in the insulin signalling (177,178,182,184). Although the issue of the involvement of PKC in the insulin stimulation of glucose transport is controversial, it is well accepted that phorbol esters or treatments that

increase the diacylglycerol levels, which lead to the activation of PKC, can induce an increase in glucose transport in many cell types including insulin target tissues (177-182). The mechanism however of PKC stimulation of glucose transport and the substrates of PKCs are not known .

1.3.2.4.3 The actin network

The cytoskeleton of eukaryotic cells plays an important role in cell shape and movement as well as in intracellular membrane vesicle and organelle traffic. The cytoskeleton consists of three main networks of proteins which are the microfilament network, the microtubule network and the intermediate filament network. A major component of the microtubule network is the protein tubulin while in the microfilament network it is the protein actin. Actin will be discussed more extensively in the following section since it is believed that the actin network is involved in intracellular traffic of proteins and specifically in translocation of glucose transporters while tubulin appears not to play an important role in this event (185).

1.3.2.4.3.1 Actin

Actin is a protein of 42 kDa. There are at least three different actin genes in mammals encoding for α , β and γ actin respectively (186). These genes are highly conserved in evolution and actin molecules from different sources can substitute for each other in functional tests in vitro.(187). Actin is found in monomeric and filamentous form. Monomeric or G actin is globular and is non-covalently bound to an ATP molecule. Filamentous actin or F actin can be formed by polymerization of G actin, a process associated with the hydrolysis of its bound ATP to ADP. However, despite the hydrolysis of ATP the polymerization event of actin does not require energy. In vitro, in media of salt concentrations normally found in living cells G actin can polymerize spontaneously into filaments and forms a viscous gel-like solution. The actin filament has a helical structure and polarity, which originates in the uniform direction of the actin monomers inside the filament, and is important for the function of the filament. The actin filament also has a fast growing end and a slow growing end. The fast growing end is also called

the plus end or barbed end because it corresponds to the barb of an arrow when actin is coated with myosin, while the slow growing end is also called minus end or pointed end because it resembles the point of an arrow. Most of the filament growth occurs at the barbed (plus) end which is always directed towards the plasma membrane of cells while the pointed (minus) end of filaments is directed towards the inside of the cell (187). It should be mentioned that actin filaments go through a cycle of polymerization and depolymerization and that the actin network of cells is a dynamic network which continuously disassembles and reorganizes. Cytochalasins are a family of fungal metabolites that can disrupt the actin network of cells. Cytochalasins bind to the barbed end of existing filaments and cap them, in this way preventing their growth, and also prevent new filament formation by binding to actin dimers. This disturbs the polymerization-depolymerization equilibrium leading to a slow disassembly of cellular actin filaments (188,189). Cytochalasins have been used widely to disrupt the actin network of cells and study its involvement and importance in specific cellular events and functions.

Upon growth factor stimulation the actin network of cells is reorganized. Filamentous actin can form bundles, also called stress fibers, which run throughout the cytoplasm of most cells. The assembly of actin stress fibers is regulated by the small GTP binding protein Rho while the reorganization of the actin network in response to growth factors is regulated by the small GTP binding protein Rac (190,191).

1.3.2.4.3.2 Role of actin in glucose transport

It has been proposed that the actin filaments provide the tracks for vesicle and organelle traffic (192) in the processes of endocytosis and exocytosis and contribute to the intracellular localization of exocytotic and synaptic vesicles in endocrine and neuronal cells (193,194)

Insulin stimulates a major reorganization of the actin network. The role of this effect of insulin is not known. The role of the actin network in the insulin stimulation of glucose transport and glucose transporter translocation was examined recently in L6 myotubes (185). Disrupting the actin network with cytochalasin D resulted in inhibition of insulin stimulation of glucose transport without affecting basal transport. The level of glucose transporters present in the

plasma membrane under basal conditions was not affected by cytochalasin D but their redistribution to the plasma membrane in response to insulin was prevented and the intracellular levels of GLUTs were decreased. It was suggested that an intact actin network is required for the correct intracellular localization of glucose transporters and their translocation to the plasma membrane in response to insulin (185).

Interestingly, however, the increase in glucose transport and glucose transporter translocation induced by other stimuli, such as by the mitochondrial ATP-production uncoupler dinitrophenol (DNP), was not affected by cytochalasin D (81) suggesting that the actin network is not essential for all stimuli of glucose transporter translocation.

1.4 AMINO ACID TRANSPORT

1.4.1 Physiological importance of amino acids

Amino acids circulate in the ionized state and account for 2-3 mEq of the negative ions in the blood. After meals the concentration of amino acids in the blood increases but the rise is small because they are absorbed within 5-10 minutes by cells throughout the entire body. For most amino acids, little is known about the role of the transport step through the membrane in the regulation of their metabolism. Immediately after entering cells amino acids are converted to proteins so that their intracellular concentration always remains low. Muscle is the main storage organ for amino acids in the form of proteins. When plasma amino acid concentrations decrease below normal levels, amino acids are transported out of the cell to replenish the supply in the plasma. Simultaneously, intracellular proteins are degraded into amino acids.

There is an upper limit to the amount of protein that can accumulate in each particular cell. Once this is reached additional amino acids are degraded, used for energy, or converted to glucose and fat (195). The liver is the major site of amino acid metabolism, and amino acid degradation takes place in this tissue. Catabolizing enzymes for the amino acids are present in the liver. Deamination results in ammonia release which in liver leads to the formation of urea. If the

liver is removed or diseased, ammonia accumulates in the blood which is toxic especially to brain leading to hepatic coma.

Certain deaminated amino acids are similar to the metabolic products that result from glucose and fatty acid metabolism. For example deaminated alanine is pyruvic acid. It can be converted to glucose or glycogen or to acetyl CoA which can then be polymerized into fatty acids.

1.4.2 Systems of amino acid transport in mammalian tissues

There are various amino acid transport systems in mammalian tissues which differ in specificity. These systems are classified based on their biochemical characteristics such as ion-dependence, kinetics and substrate specificity. Depending on the amino acids transported these systems can be categorized into neutral, basic and acidic. It should be noted that although each amino acid transport system is distinct there is an overlapping substrate specificity between the different systems. It should also be kept in mind that most of the studies of amino acid transport have been carried out in cell culture and therefore the conclusions obtained about their regulation may not always be relevant to the *in vivo* system. Table 1.1 includes some of the known amino acid transport systems and their preferred substrates.

Neutral amino acid transport in mammalian tissues is mediated predominantly by systems A, ASC, L and N^m each having unique characteristics but overlapping specificity as mentioned above. The overlapping substrate specificity makes targeted biochemical studies difficult and therefore various strategies that provide specificity have been derived. For example, for the measurement of system A activity N-methylamino- α -isobutyric acid (MeAIB) is used as a substrate which is uniquely transported by system A. However for the study of system ASC activity radioactive aminoisobutyric acid (AIB) and cycloleucine (a nonmetabolizable analog of leucine) are used in the presence of excess non radioactive substrates of system A and L, MeAIB and 2-amino-2-norbornane carboxylic acid (BCH), respectively (196).

Table 1.1. Amino acid transport systems in mammalian cells

Some of the most common amino acid transport systems expressed in mammalian cells are shown in this table. Their preferred substrates and their Na⁺-dependence are also included.

Category	System	Substrates	Na⁺-dependence
Neutral	A	alanine, proline aminoisobutyric acid(AIB) methylAIB (MeAIB)	+
	ASC	alanine, serine, cysteine	+
	L	leucine	-
	Nm	glutamine	+
	Basic	y ⁺	lysine, arginine, ornithine
b ^{0,+}		arginine, alanine, cysteine	+
Acidic	X _{AG} ⁻	glutamate	+

The amino acid transport system A mediates the transport of neutral short chain (linear aliphatic) amino acids (such as alanine) and the imino acid proline and is also capable of mediating the transport of N-methylated amino acids such as the nonmetabolizable alanine analog MeAIB. System A is present in nearly all mammalian cell types, including skeletal muscle and it is Na^+ -dependent. It appears to function as a cotransporter. It transports amino acids into cells together with Na^+ , which is actually transported along its concentration gradient and provides the driving force for transport.

System ASC transports the neutral amino acids alanine, serine and cysteine and it is Na^+ -dependent. Recently, a cDNA has been cloned from human hippocampus encoding a protein (with similarity to the human glutamate transporter) that has characteristics similar to the ASC system (197).

System L mediates the uptake of nonpolar, long chain and aromatic amino acids such as leucine, isoleucine, phenylalanine and tyrosine, and is also largely responsible for the transport of nutritionally essential neutral amino acids. It is Na^+ -independent and is ubiquitously expressed in animal cells and tissues. Recently the cDNA of a system L transporter has been cloned from a rat kidney library using a xenopus oocyte expression system (198). The transporter was found to have four putative membrane spanning domains and exhibits many but not all of the characteristics of L-system transporters, suggesting that this represents one of several related L-system transporters. Cloning of other systems may also reveal that a number of subtypes or isoforms of a certain transporter exist.

System N^{m} transports the neutral nonessential amino acid glutamine. It is Na^+ dependent and in primary cultures of skeletal muscle insulin increases its activity (by 30-40%) by increasing the V_{max} that is dependent on protein synthesis (199).

Basic system y^+ mediates the flux of cationic amino acids and has recently been cloned and identified as the previously identified receptor for the ecotropic murine leukemia virus (200,201). It is not Na^+ -dependent and transports amino acids such as lysine, arginine and ornithine and is ubiquitously expressed .

The acidic amino acid system X_{AG}^- is referred to as the glutamate receptor. System X_{AG}^- has widespread distribution and it is Na^+ -dependent. System $b^{0,+}$ mediates the transport of dibasic and neutral amino acids such as arginine, alanine and cysteine. This system has been cloned recently (202). It is Na^+ -independent and its mRNA has been found in kidney and intestine.

The neutral amino acid system A is the best studied in both skeletal muscle tissue and skeletal muscle cells in culture. It is regulated by insulin and is the focus of some of the studies presented in this thesis. The regulation of this system is briefly reviewed in the following section.

1.4.3 Regulation of system A amino acid transport

The activity of system A amino acid transport is regulated by hormones (203), growth factors (204), nutritional conditions (205), the electrochemical potential across the cell membrane (206,207) and other effector substances such as prostaglandins (PGE₂) and retinoic acid (208,209).

The major hormone shown to regulate system A is insulin. The effect of insulin is acute (within 30 min) and is manifested as an increase in V_{max} without a change in K_m , as assessed in muscle tissue using the alanine analog MeAIB (210). The effect of insulin is not dependent on protein synthesis (see Table 5.3 and (210)). The precise mechanism has not been defined since the system A transporter has not been cloned. There may be a translocation phenomenon similar to that described for other proteins such as GLUT4 (see above) and/or an increase in intrinsic activity. Furthermore, recently it has been shown that PI 3-kinase may be involved in the stimulation of system A amino acid transport by insulin since wortmannin abolished the response of the cells to the hormone (65).

Apart from insulin, IGF-1, has a similar action on system A amino acid transport (211). As discussed above a number of amino acid transporters including system A are coupled to a Na^+ gradient and are thus Na^+ and pH dependent (195). Acidification of the extracellular medium can increase system A transport activity (212).

Glucagon also acutely increases system A amino acid transport. Amino acid transporters function in a bidirectional manner as do glucose transporters and therefore an increase in V_{max} may result in increased transmembrane transport in a direction which depends on the concentration gradient. Thus an increased activity may be beneficial whether amino acids are required within cells for new protein synthesis or for delivery to the circulation and liver for use as an energy source, e.g. during starvation. The liver uptake of system A amino acid transport substrates can be increased by insulin to augment protein synthesis. In addition glucagon or increased extracellular amino acid levels following protein ingestion also lead to increased amino acid uptake in liver which lead to conversion of amino acids to glucose. Such events take place during starvation or glucose deprivation.

One of the most important mechanisms of amino acid transport system regulation is that by the amino acids themselves. Thus incubation of cells in high concentrations of amino acids transported by system A downregulates or decreases transport activity while, amino acid deprivation augments it (205,213,214). This type of regulation is referred to as adaptive regulation and it has been found to be dependent on RNA and protein synthesis. Inhibitors of protein synthesis, inhibition of total RNA synthesis, polyadenylation, or glycoprotein biosynthesis, have all been reported to inhibit the increase in activity subsequent to amino acid deprivation (215). These data suggest that possibly synthesis of new transporter proteins and/or synthesis of system A-associated regulatory components takes place and mediates adaptive regulation.

System A transport activity has been reported to decrease in response to increased extracellular amino acid concentrations. The regulatory elements involved in these events have been suggested to be associated with histone mRNAs that typically cause repression (216). Under such conditions the amino acids present, mainly substrates of system A, may enhance the transcription of genes encoding proteins that can inactivate system A (216). Although it was thought that only amino acids transported by system A regulate its activity, recently it has been reported that other amino acids that are not system A substrates may modulate its activity (217). Therefore it has been reported that leucine can increase system A transport by a mechanism

involving an increase in V_{\max} without any changes in K_m that depends on protein synthesis and is distinct from that involved in the growth factor-stimulated system A activity (218).

1.5 L6 MUSCLE CELLS

Cultured cells and cell lines have been used extensively to study hormonal and metabolic processes. Cell monolayers have many advantages including the fact that the population of cells is homogeneous, the intercellular space is limited and all cells are exposed equally to metabolic substrates and exogenously added agents. Thus, specific effects of various agents can be examined in isolation while *in vivo* studies are complicated by multiple inputs. Cell lines in general are viable for extended periods of time and therefore represent excellent models in which to assess the specific effects of both acute and chronic hormonal and nonhormonal stimuli.

Two insulin-responsive cell lines, the rat L6 skeletal muscle cells and 3T3-L1 murine fatty fibroblasts have been extensively utilized to study the mechanisms of insulin action and regulation of glucose transport. These two cell lines are the only cell lines which differentiate in culture and express the insulin-responsive GLUT4 glucose transporter. Furthermore, in the differentiated state there is an acute response to insulin to increase glucose transport associated with the well documented translocation of glucose transporters (see above).

The L6 muscle cell line was derived from one day old rat thigh muscle satellite cells and retains many morphological, biochemical and metabolic properties of skeletal muscle (219). These cells grow as mononucleated myoblasts and upon confluency, in the presence of low concentrations of serum, differentiate spontaneously into elongated multi-nucleated myotubes (220,221). The morphology of the L6 cells in the myoblast and myotube stage is shown in Figure 1.8.

L6 myotubes express many of the biochemical properties (219), electrical/contractile activity (222), and proteins characteristic of mature skeletal muscle (223). They express myogenin, a muscle-specific transcription factor which controls the expression of many muscle specific genes during the myogenic process (224). Acetylcholine receptor, creatine kinase,

Figure 1.8 L6 skeletal muscle cells in the myoblast and the myotube stage



L6 cells were grown in 6-well plates for 2 and 7 days to be in the myoblast (top) and myotube (bottom) stage respectively. The cells were fixed in 2.5 % glutaraldehyde and 50% ethanol and then were stained with Giemsa and photographs were taken using a photographic camera attached in a phase contrast microscope. The photographs are magnified 440 times.

muscle actin and myosin heavy chain, and the GLUT4 glucose transporter are muscle specific proteins expressed in L6 myotubes (225,226).

As L6 cells differentiate from myoblasts to myotubes, insulin receptor number increases by 3-fold (227,228) while IGF-1 receptor levels are reduced by about 80% (229). L6 myotubes express GLUT1, GLUT4 and GLUT3 glucose transporters (226,230) and the expression of GLUT4 increases with differentiation (226). While basal glucose transport decreases, the acute and chronic stimulation of glucose transport by insulin increases (220,228). In L6 myotubes, although GLUT1 and GLUT3 are present in intracellular compartments, the majority of these transporters are localized at the plasma membrane and probably account for most of the basal glucose uptake. On the other hand the majority of the GLUT4 transporter is localized intracellularly. L6 myotubes respond to insulin with a rapid increase in the rate of glucose transport that is associated with a recruitment of all 3 GLUTs; GLUT1, GLUT3, and GLUT4 proteins to the plasma membrane from intracellular membrane compartments (231). L6 myotubes also respond to insulin with a rapid increase in system A amino acid transport activity. Both of these are responses which are similar to those observed in skeletal muscle.

Although L6 muscle cells have many of the characteristics of skeletal muscle, it is important to note that they are not identical. For example GLUT3, originally cloned from a fetal human skeletal muscle cDNA library, is absent in adult skeletal muscle (120). The actin network of L6 myotubes does not form the contractile sarcomeres found in skeletal muscle fibers and the tissue culture model does not replicate the physiological cell-cell interactions and innervation found in vivo. These differences may reflect and give rise to responses characteristic of a more "fetal" or less well differentiated phenotype. In terms of glucose transport response to insulin, the extent of stimulation is somewhat lower, 2-fold as compared to 4-5 fold in skeletal muscle (232,233). This difference may be due to somewhat higher GLUT1 expression, which contributes mainly to basal glucose transport, and the lower GLUT4 levels, which contributes to the insulin-stimulated glucose transport in L6 myotubes compared to skeletal muscle.

Despite these differences, the many similarities mentioned above make L6 cells the best tissue culture model of skeletal muscle available today and provide a valuable tool to investigate

the mechanisms of insulin action as well as the action of other agents affecting glucose and/or amino acid uptake and metabolism.

1.6 TREATMENT OF DIABETES MELLITUS

As already mentioned above, Diabetes Mellitus is the name given to a group of diseases characterized by hyperglycemia. It is classified into two major groups, Insulin Dependent or Type I diabetes mellitus and Non-insulin-dependent or Type II diabetes mellitus (IDDM and NIDDM respectively)(234). Type I diabetes is characterized by an earlier age of onset (usually <40 years) and insulin deficiency. There is destruction of the pancreatic islet β -cells by an immunological process which is not completely understood (3). Replacement of insulin with exogenously administered insulin is the only treatment at present. Type II diabetes is characterized by both insulin resistance as well as insulin deficiency (4,235). Although both abnormalities are present in established Type II diabetes, there remains controversy about the initiating lesion. Recent studies suggest that Type II diabetes may not be one but rather a group of several diseases, in some cases the primary defect being insulin deficiency and in others, insulin resistance (4).

The majority of people afflicted with Type II diabetes are obese and obesity is associated with insulin resistance. Furthermore long term studies have demonstrated that the presence of insulin resistance in children whose parents both have diabetes is a major determinant of the future development of Type II diabetes (4). It has also been found that first degree relatives of people with Type II diabetes with normal glucose tolerance are insulin resistant (236). These data suggest that insulin resistance is an integral component of the pathophysiology of Type II diabetes being present both in the early and the later stages of the disease.

The causes of the insulin resistance appear to be multiple. Studies attempting to localize the biochemical abnormalities in the insulin action pathway have defined many defects (237). Most of these appear to be acquired but genetic defects have also been found in some cases. One of the most extensively documented is the form of diabetes associated with severe insulin

resistance caused by genetic defects in the insulin receptor (238,239) (240). Although there has been a suggestion of differences in IRS-1 sequences in a proportion of people with Type II diabetes assessed by restriction fragment length polymorphism (241) there are no other well-defined genetic defects in the insulin signalling pathway causing diabetes. On the other hand a number of studies have shown defects in insulin binding (242), insulin-stimulated receptor autophosphorylation and kinase activity (19,20,243), IRS-I phosphorylation (244), and PI 3-kinase activity (163). These defects are at least partially reversible and appear to be acquired (245). They coexist with the impairment of insulin-stimulated glucose transport activity and glycogen synthase activity (246) documented in Type II diabetes. Since all the steps in insulin signal transduction have not been defined, it is possible that other defects will be found.

In view of the pathophysiology of Type II diabetes, treatment is directed at improving either or both insulin deficiency and insulin resistance. The first line of therapy is diet and exercise. A lowering of caloric intake with weight loss and an increase in exercise both increase insulin sensitivity and may result in improvement in metabolic abnormalities.

The most commonly used pharmacological agents to treat Type II diabetes are members of the sulfonylurea family which increase insulin secretion and may have some effect on peripheral glucose uptake (247,248). A detailed review of the mechanisms of action of these agents is presented in Chapter 2.

A second family of agents are the biguanides of which metformin is the only member currently employed. Metformin does not increase insulin secretion but acts in insulin target tissues. In the liver metformin inhibits gluconeogenesis (249) and in muscle it appears to increase glucose uptake (250). These actions on human muscle (251) were also demonstrated in L6 myotubes (252), another example of the utility of this tissue culture system to serve as a model of skeletal muscle. Finally if neither of these agents alone or in combination are effective, insulin may be used.

A newer class of hypoglycemic agents under investigation are the thiazolidinedione derivatives, examples of which are the compounds pioglitazone and troglitazone (253). Troglitazone has been shown to improve insulin sensitivity and glucose tolerance in NIDDM

patients (254) and in obese subjects (255). These compounds potentiate insulin action on peripheral glucose utilization and reduce hepatic glucose output (256,257) and they are also known as insulin sensitizers. Their direct action on peripheral glucose utilization is also supported by in vitro studies. For example, in L6 muscle cells it was shown that long-term (72 h) troglitazone treatment increased basal glucose uptake in the absence of insulin (256,257). These agents do not have any influence on β -cell function (254). Their mechanism of action appears to involve binding to the PPAR γ (peroxisome proliferator-activated receptor γ) receptor, a nuclear receptor superfamily member which is involved in transcriptional regulation of adipose cell differentiation (258). In one study, however, insulin resistance induced by high fat diet in rats was not prevented by troglitazone (259). Therefore the exact role of these agents in the treatment of diabetes is not yet clear. Further studies of compounds which can alter glucose homeostasis and/or the mechanism of insulin action and correct the abnormalities in Type II diabetes are important for the development of additional effective therapy. One such potential agent is vanadium. The action and chemistry of vanadium compounds are reviewed in Chapter 4.

1.7 RATIONALE

The physiological role of glucose transport into muscle tissue is well established. Muscle is quantitatively the most important tissue accounting for insulin-mediated glucose uptake and in diseases characterized by insulin resistance such as Type II diabetes, insulin-stimulated muscle glucose uptake is severely impaired. The biochemical processes within the muscle cell which serve to regulate both basal and insulin-stimulated glucose uptake are not completely understood. The localization, function, synthesis and degradation of glucose transporters may all contribute to such regulation by hormones and metabolites. At the same time, pharmacological agents which are used to treat people with Type II diabetes, such as sulfonylureas, or are being investigated for such a use, e.g. vanadium compounds, are known to have effects on muscle glucose uptake. The purpose of the experiments presented in this thesis was to document the diverse biological effects (insulin-like and noninsulin-like) and the mechanism of action of these agents. Such studies not only serve to better define the actions, utility and potential adverse effects of a therapeutic agent, but also serve as a probe of cellular mechanisms which may operate in normal physiological processes to regulate function. In the first of these studies the new sulfonylurea compound gliclazide was chosen to examine and compare its effects and mechanism of action to glyburide, an older well established drug used in humans. The following questions were addressed in the first study:

1. Do sulfonylureas have any direct extra-pancreatic effects to stimulate glucose uptake in muscle?
2. Are there any unique peripheral effects of the novel sulfonylurea gliclazide as compared with the older structurally different sulfonylurea glyburide on glucose transport in muscle cells ?
3. Do sulfonylureas have peripheral actions independent of insulin ?
4. Is there an action on glucose transporter proteins ?
5. What is the mechanism of this action on glucose transporters ?

In the studies presented in Chapter 5 and 6 the effects and the mechanism of action of vanadium compounds were examined. As mentioned in more detail in Chapter 4 these interesting

compounds are insulin-mimetic and dramatically improve glucose homeostasis in rodents with diabetes. Their inhibitory action on protein tyrosine phosphatase (PTPs) make them unique probes of cellular function. Their potential as therapeutic agents is under active investigation.

In the studies presented in Chapter 5 and 6 of this thesis the following questions were addressed:

1. Do vanadium compounds mimic all of the actions of insulin in skeletal muscle; specifically glucose and amino acid transport ?
2. What is the interaction of vanadium compounds with insulin in relation to these biological effects?
3. What is the mechanism by which vanadate and pervanadate stimulate glucose transport in muscle cells; specifically, is the mechanism of action of vanadium compounds similar to that employed by insulin ?

For all these studies the model system used was L6 rat skeletal muscle cells. Their characteristics and the rationale for their use have been reviewed in Chapter 1. As outlined in the chapters that follow novel observations have been made regarding the actions and cellular effects of both these agents.

CHAPTER 2

BACKGROUND ON SULFONYLUREA COMPOUNDS

2.1 SULFONYLUREA DRUGS IN THE TREATMENT OF DIABETES

Work in the 1940's and 1950's led to the discovery and development of the hypoglycemic sulfonylurea compounds. Janbon and colleagues were studying the antibacterial potency of p-amino-sulfonamide-isopropyl-thiodiazole (RP 2254) in patients with typhoid fever and noticed that it could cause severe hypoglycemia (247). Later it was shown by Loubatieres that the sulfonamide group was essential for hypoglycemic activity and that sulfonamides lowered blood glucose levels in dogs that had undergone partial but not total pancreatectomy (260). In the years that followed, testing of various derivatives led to the synthesis in Germany of carbutamide and tolbutamide the first hypoglycemic sulfonylureas. By the mid of 1960's four compounds (tolbutamide, tolazamide, acetohexamide, and chlorpropamide) with somewhat different potencies, duration of action and metabolism were widely used for the treatment of NIDDM. During that time, the University Group Diabetes Program study suggested that tolbutamide was associated with an increased risk of cardiovascular mortality (261). Although this study was criticized and its results questioned, the use of sulfonylureas declined considerably. In the late 1970's the use of sulfonylureas regained popularity and in the 1980's the sulfonylureas glipizide and glyburide that had been available in Europe for many years were introduced to the North American market. More recently in 1990, another sulfonylurea compound, gliclazide was introduced in Canada. Thus sulfonylureas have contributed for many years to the treatment of Type II (non-insulin dependent) diabetes mellitus and those most commonly used are included in Table 2.1

2.2 BIOCHEMICAL CHARACTERISTICS OF SULFONYLUREA COMPOUNDS

All sulfonylurea compounds have structural similarities. A similar core structure is bound to different substitutions on its ends that result in pharmacological differences. The structure of some sulfonylurea compounds including glyburide and gliclazide is shown in Figure 2.1. The central sulfonamide group (shown in the box) is required for their hypoglycemic action.

Table 2.1 Oral hypoglycemic agents used in the treatment of Type II Diabetes

Sulfonylureas and biguanines are hypoglycemic agents commonly used in the treatment of patients with type II diabetes while the thiazolidinediones are a new class of compounds still in experimental level.

Family of compound	Compound
Sulfonylureas	
(First generation)	tolbutamide acetohexamide tolazamide chlorpropamide
(Second generation)	glipizide glyburide gliclazide
Biguanides	metformin
Thiazolidinediones	troglitazone pioglitazone

Figure 2.1 Structure of sulfonylurea drugs

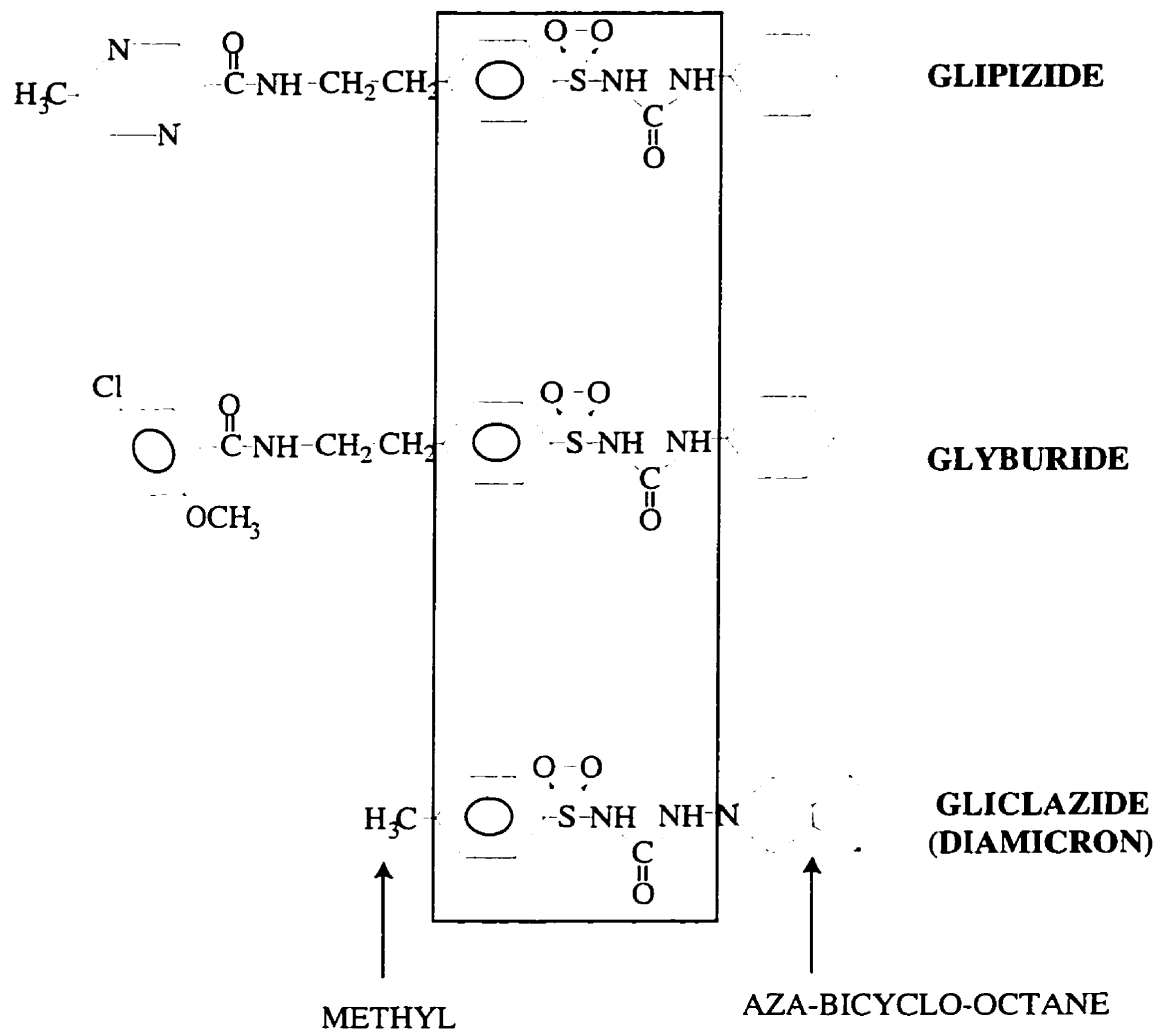

Note that the area in the box represents the central sulfonamide group common in all sulfonylureas while the side groups are unique to each different compound.

Different groups exist on each side of the sulfonamide group, e.g. gliclazide has an azabicyclooctane group, and a methyl group. These sulfonylurea compounds differ in potency, duration of action, metabolism, side effects and perhaps other properties.

All sulfonylureas are highly protein bound, particularly to albumin. Depending on the compound 98-99% is bound. For example, tolbutamide is 98% protein bound at plasma concentrations of 6-25 μM , while glipizide is 99% protein bound at plasma concentrations of 4-40 nM (262). Also all sulfonylureas are highly lipid soluble and cross the capillary walls rapidly. Therefore the free drug concentration at the target cell is similar to the plasma concentration of the free drug. Finally, all sulfonylureas are in great part converted by the liver to inactive or less active metabolites, with the exception of acetohexamide which is converted to a more active form. Metabolites and residual quantities of the parent compounds are eliminated predominantly in urine.

Two different generations of sulfonylurea drugs exist. The more recently introduced second generation agents have certain advantages. They are more potent on a weight basis so that smaller doses are required, they result in less Na^+ retention and they have fewer interactions with other medications because of nonpolar protein binding (263). Today, mostly second generation compounds are used in the treatment of NIDDM.

2.3 EFFECTS OF SULFONYLUREAS

2.3.1 Pancreatic effects of sulfonylureas

2.3.1.1 Insulin secretion

Initial studies by Loubatieres in 1944 showed that injection of p-aminosulfonamide-isopropyl-thiodiazole (RP 2254) into depancreatized or alloxan diabetic dogs did not affect the blood glucose levels. However an effect was seen on blood glucose levels in control treated with RP 2254 (260). These findings suggested that the pancreas was essential in order for the drug to

exert an effect on blood glucose levels. The requirement of the pancreas suggested that insulin secretion was increased by these agents. The evidence for this concept came from experiments in which insulin and C-peptide levels were determined in the peripheral blood following intravenous injection or oral sulfonylurea administration (264-266). Many studies have now confirmed that acute administration of sulfonylureas to animals or man results in an increase in insulin secretion (266,267). Similarly, addition of sulfonylureas to isolated islets, or perfused pancreas causes an immediate release of insulin into the medium (248,268,269). In NIDDM patients the contention that treatment with sulfonylureas results in an increase in insulin secretion is supported by the increase seen in mean plasma insulin levels (270-272). In vitro the release of insulin can be observed in the absence of other secretagogues. In vivo however it is suggested that the major effect is to increase β -cell sensitivity to glucose (273). Glucose stimulates insulin secretion in a biphasic fashion, with a rapid first- phase burst observed within 0-10 min followed by a slower second phase (10-60 min). In NIDDM the first phase is lost early on and the second phase of insulin secretion is subsequently impaired (274). Most studies have been unable to demonstrate any appreciable effect of sulfonylureas on first phase insulin secretion in NIDDM patients (269,275). However there are reports that gliclazide treatment of NIDDM patients does improve the first phase of insulin secretion (273,276). The second phase of insulin release increases linearly with the plasma glucose concentration. Sulfonylureas enhance this β -cell responsiveness, that is more insulin is released at every glucose level and the effect of glucose and sulfonylurea on the second phase insulin secretion is additive (269,275).

Long term (6-12 months) treatment with sulfonylureas in animals and man has been reported to result in no change or even a decrease in plasma insulin levels and a significant decrease in glucose-mediated insulin release (271,272,277,278). The mechanisms contributing to these effects are presently unknown but may be related to increased sensitivity to insulin (272,279). This improvement in insulin resistance is due at least in part to the improved metabolic control (280), but may also be related to direct extrapancreatic effects of the drugs (see below). Other studies suggest that although the basal insulin secretion rates are not changed with

sulfonylurea therapy the total amount of insulin secreted over 24 h increases (267) suggesting that sulfonylureas maintain their insulintropic action during chronic therapy.

2.3.1.2 Other pancreatic effects

Some studies suggest that sulfonylureas possibly inhibit the release of glucagon *in vitro* (281,282). In plasma of NIDDM patients treated with sulfonylureas for long term a decrease in glucagon levels were observed in some (283) but not all (284) studies. The mechanism involved in glucagon secretion and the importance of this event is unclear. It may be the consequence rather than the cause of improved glucose control. As well, somatostatin release by the isolated perfused rat pancreas has been reported to be stimulated by glyburide at low glucose concentrations (285) and the importance of this finding remains uncertain.

Loubatieres (1946) found that the sulfonylurea compound RP2254 could increase the volume and weight of the pancreas and even induce the formation of islets of Langerhans in rats treated with the compound. This suggested that sulfonylureas have β -cytotrophic effects. However these observations have not been confirmed by others.

2.3.2 Extrapancreatic effects of sulfonylureas on fat and muscle cells

Sulfonylureas do not reduce plasma glucose levels in animals in which the β -cells of the pancreas have been destroyed or removed and they are ineffective in patients with IDDM who lack β -cell function. Nevertheless, there is evidence that these agents may reduce hyperglycemia in patients with NIDDM by means other than increasing insulin secretion.

As mentioned above, although many studies have shown that the hypoglycemic action of sulfonylureas is primarily due to an increase in pancreatic insulin secretion, it has been observed that elevated plasma insulin concentrations in sulfonylurea-treated subjects or rodents return to pretreatment levels after chronic administration while blood glucose levels were normalized suggesting that sulfonylureas enhance glucose uptake and metabolism in peripheral tissues and improve insulin sensitivity (271,272,286,287). Furthermore, it has been reported that the acute

response of the pancreas (increase in C-peptide and insulin levels) to glyburide is lost in patients chronically treated with sulfonylureas while the glucose lowering effect is maintained suggesting extrapancreatic effects of the drugs (288).

To test this possibility a number of studies have been performed in cell culture models of insulin target tissues of skeletal muscle and fat examining the effects of sulfonylureas on glucose transport (summarized in Table 2.2). In some of the studies the presence of insulin was required to observe the sulfonylurea effect (289-292), while in other studies a direct effect of sulfonylureas on peripheral insulin target tissues was observed in the absence of insulin (293,294). Thus sulfonylureas directly stimulate glucose transport in BC3 H1 and L6 muscle cells (293-296), in 3T3-L1 adipocytes (297,298) as well as in primary cultures of rat adipocytes (299-302). An effect on glycogen synthesis was also seen in some studies. In L6 cells glyburide increased glucose transport and glycogen synthesis 2 fold without any change in glycogen synthase or phosphorylase activity indicating that the increase in glycogen synthesis was due to the increase in glucose transport (295). Glycogen synthase activity was also unchanged in muscle biopsies from fasting NIDDM patients receiving gliclazide therapy although in these patients insulin stimulation of glycogen synthase activity was potentiated (303). It should be noted that the concentrations of sulfonylureas required to see an in vitro effect are usually higher than those found in circulating blood of patients treated with the drugs. This is probably due to cell culture characteristics, it is also seen with other drugs and hormones and does not exclude in vivo relevance.

2.3.3 Effects of Sulfonylureas on liver

The effect of sulfonylureas on hepatic glucose production is not clear. In rats chronically (6-18 days) treated with glyburide, the basal hepatic glucose production was greater than control rats and the sensitivity of the liver to suppression of glucose production by insulin was unchanged (287). Also glipizide treatment of normal dogs did not result in any increase in insulin suppression

Table 2.2 Effect of sulfonylureas on glucose uptake in tissues and cell culture models of insulin targets.

In all studies glucose uptake was stimulated by sulfonylureas. Differences were observed in the requirement for insulin and an effect on basal versus insulin-stimulated glucose uptake (see text for details).

Tissue	Compound	Concentration	Time of exposure	References
adipocytes	tolazamide	.003-300 μ g/ml	20-44h	(300)
	glyburide	20-40 μ M	30-60 min	(301)
	glyburide	2 μ M	48 h	(302)
	tolbutamide	1-2 mM	30-60 min	(299)
3T3L1	tolbutamide	1.5 mM	1-3 days	(297,298)
BC3H1	tolbutamide	2-3 mM	20 h	(294)
	tolbutamide	1 mM	30 min	(293)
	glipizide	4 μ M	20 h	(294)
	glyburide	4 μ M	20 h	(294)
	glyburide	20-100 μ M	30 min	(293)
L6 cells	glyburide	2 μ g/ml	4-6 h	(295)
	glyburide	1 μ g/ml	2-6 h	(296)
	tolazamide	0.6 mg/ml	22h	(289)

of hepatic glucose output although total glucose uptake with both low and high insulin doses was greater with the glipizide therapy (304). These findings suggest that the increase in glucose disposal seen with sulfonylurea treatment was not due to a decrease in hepatic glucose production but to peripheral glucose uptake. In NIDDM patients however long term sulfonylurea therapy resulted in a significant reduction of hepatic glucose production (271,272,305).

2.3.4 Effect on glucose transport in the intestine

Sulfonylureas may reduce the absorption of ingested glucose by the small intestine. Using an isolated *in vitro* preparation of a complete functional intestinal-pancreatic unit it was found that gliclazide at levels likely to be found in the gastrointestinal tract (200 µg/ml) reduced the transport of glucose across the intestinal lumen in either direction. This was due to an increase in the metabolic utilization of glucose by the intestine (306). However the importance of this finding is not known and apart from this study the same issue has not been addressed by other investigators.

2.3.5 Other effects of sulfonylureas

In diabetes plasma fibrinolytic activity is decreased, excessive platelet aggregation and adhesiveness is also observed and plasma thrombotic activity is increased. The novel sulfonylurea gliclazide has been reported to correct the decrease in plasma fibrinolytic activity (probably via the inhibitor of plasminogen), correct excessive platelet aggregation and adhesiveness and reduce the increased thrombotic activity of diabetes (307). These potentially anti-atherogenic properties have been attributed to the unique side group of this agent (see Figure 2.1) since they appear to be independent of changes in glucose concentration (308). Although it has been suggested that these effects may have direct benefit to decrease the vascular complications of diabetes, this remains to be proved.

2.4 SULFONYLUREA SIGNALLING

2.4.1 The sulfonylurea receptor

Early studies suggested that the family of sulfonylurea compounds initiate their signalling events by binding to specific sites at the plasma membrane. The existence of a specific binding site for sulfonylureas at the plasma membrane of β -cells was demonstrated initially by using radioactive sulfonylurea compounds. These sites were characterized in various insulin secreting beta cell lines such as RIN m5F and HIT cells and isolated pancreatic β -cells using [^3H]glyburide (309,310). The binding of the radioactive sulfonylurea compound was saturable and competitively inhibited by other sulfonylureas such as glipizide, tolbutamide or tolazamide. High and low affinity binding sites were identified (311). Subsequently it was found, using ^{86}Rb efflux and the patch-clamp technique, both of which permit the study of K^+ flux, that sulfonylureas inhibit the efflux of K^+ ions from β -cells via channels with the characteristics of ATP-dependent K^+ channels (309,312). The order of potency of sulfonylurea compounds in binding to β -cells correlated well with their potency to inhibit the efflux of K^+ ions and to stimulate the release of insulin *in vivo* (309).

All the above studies indicated that ATP-sensitive K^+ channels and sulfonylurea receptors were functionally linked although it was not clear whether these constituted a single entity. It was proposed however based on biochemical studies that the ATP-sensitive K^+ channel contained a sulfonylurea binding domain, as well as a binding site for K^+ channel openers, which include pharmacological agents used in cases of excessive insulin secretion such as in insulinomas, and two or more nucleotide binding sites that can discriminate between ATP and ADP.

In peripheral tissues such as muscle and adipocytes the existence of sulfonylurea binding sites has been difficult to prove probably because their abundance is much less compared to β -cells and /or differences in their affinity for sulfonylurea compounds. Studies have shown that different subtypes of ATP-sensitive K^+ channels exist with different sensitivities to inhibition by sulfonylureas (313,314). Thus in insulinoma cells the k_d of sulfonylurea hypoglycemic drugs

for half maximal inhibition of [³H]glyburide binding is 0.1-0.2 nM while in cardiac cells it is 2 nM and, in skeletal muscle cells it is 200 nM (314). The presence of sulfonylurea binding sites in peripheral tissues has been investigated not only with binding studies using [³H]glyburide (301), but also using the ⁸⁶Rb efflux, and the patch-clamp technique. [³H]glyburide was found to bind to adipocyte membranes at specific saturable sites suggesting that a specific sulfonylurea binding protein is present in plasma membrane of adipocytes that possibly plays a role in the extrapancreatic effects of sulfonylureas (301). Similarly high affinity binding sites for sulfonylureas were identified in avian and mammalian heart cells (315). In cardiac muscle (316), frog skeletal muscle fibres (317,318), mouse skeletal muscle (314,319), as well as in human skeletal muscle (314,320) ATP-sensitive K⁺ channel activity was measured by patch-clamping and found to be inhibited by sulfonylureas.

In contrast to these studies, Rajan et al could not detect a functional high affinity sulfonylurea receptor in plasma membranes from rat adipocytes and 3T3-L1 cells by either iodinated glyburide binding or ⁸⁶Rb efflux (321).

Glyburide and 5-iodo-2-hydroxy-³H-glyburide, an iodinated derivative of glyburide, in HIT cell membranes could be cross-linked by photolabelling to a protein with an apparent molecular size of 140 kDa which most likely represented the sulfonylurea receptor (311). Using this iodinated derivative of glyburide the sulfonylurea receptor was recently purified from HIT T15 cells, its amino terminus was sequenced and primers were designed and used to clone the sulfonylurea receptor cDNA by screening a cDNA library from an α -cell line initially and then RINm5F and HIT T15 cell libraries (322). This cDNA was found to encode the rat and hamster high affinity sulfonylurea receptor. Cells (COSm6) transfected with the rat or hamster sulfonylurea receptor cDNA were found to express a 140 kDa band that comigrated with native sulfonylurea receptor from HIT cells and specific photolabelling was specifically inhibited by glyburide. The sulfonylurea receptor appears to be a member of the traffic ATPase also known as the ATP-binding-cassette(ABC) transporter superfamily (322). The molecule has nine membrane spanning regions and two nucleotide binding folds. It also has 3 potential protein kinase A and 20 potential protein kinase C phosphorylation sites consistent with the suggestion

that phosphorylation alters the affinity of the receptor for various ligands and regulates the activity of the ATP-sensitive K^+ channel. Preliminary efforts to assay sulfonylurea receptor for ATP-sensitive K^+ channel activity were negative. Microinjection of sulfonylurea receptor into *Xenopus* oocytes and patch clamping studies did not show any new K^+ current suggesting either that recombinant sulfonylurea receptor does not have intrinsic K^+ channel activity or that *Xenopus* oocytes are not an adequate background for its expression. It should be noted that at least in one study the mRNA of the sulfonylurea receptor was present in pancreas, heart and spleen, but not in skeletal muscle by northern blotting (322). Further study using PCR will be helpful to determine whether low levels may be present in other tissues.

Mutations in the sulfonylurea receptor that truncate the second nucleotide binding fold cause persistent hyperinsulinemic hypoglycemia of infancy (323), a disease associated with unregulated insulin secretion. Based on this discovery it was hypothesized and predicted by the investigators who cloned the sulfonylurea receptor that it is an integral part of the ATP-sensitive K^+ channel and specifically, it functions as the ATP and ADP sensor (322,323). However, more recent studies have shown that overexpression of the sulfonylurea receptor in HEK293 cells, although increased sulfonylurea binding ($[^3H]$ glibenclamide), did not affect the magnitude of the endogenous whole-cell current measured in whole cell patch clamp (324). This result suggested that the sulfonylurea receptor itself does not form an ion channel. Furthermore, it was found that the sulfonylurea receptor can confer sulfonylurea sensitivity on inwardly-rectifying K^+ (K_{ir}) channels without the development of ATP-sensitivity. It was concluded that the sulfonylurea receptor is a regulator of multiple K_{ir} channels and the presence of sulfonylurea sensitivity cannot be taken to indicate specifically the presence of ATP-sensitive K^+ channels. Furthermore ATP-sensitive channels may exist in certain tissues or cell types which lack sulfonylurea sensitivity since the regulator protein is not present in all tissues (322).

2.4.2 Mechanism of action of sulfonylureas in the pancreas

The mechanism by which insulin is released from the pancreatic β cells after the increase in blood glucose levels is shown in Figure 2.2. Pancreatic cells express the GLUT 2 isoform

Figure 2.2. Mechanism of insulin secretion in β -cells and mechanism of sulfonylurea action

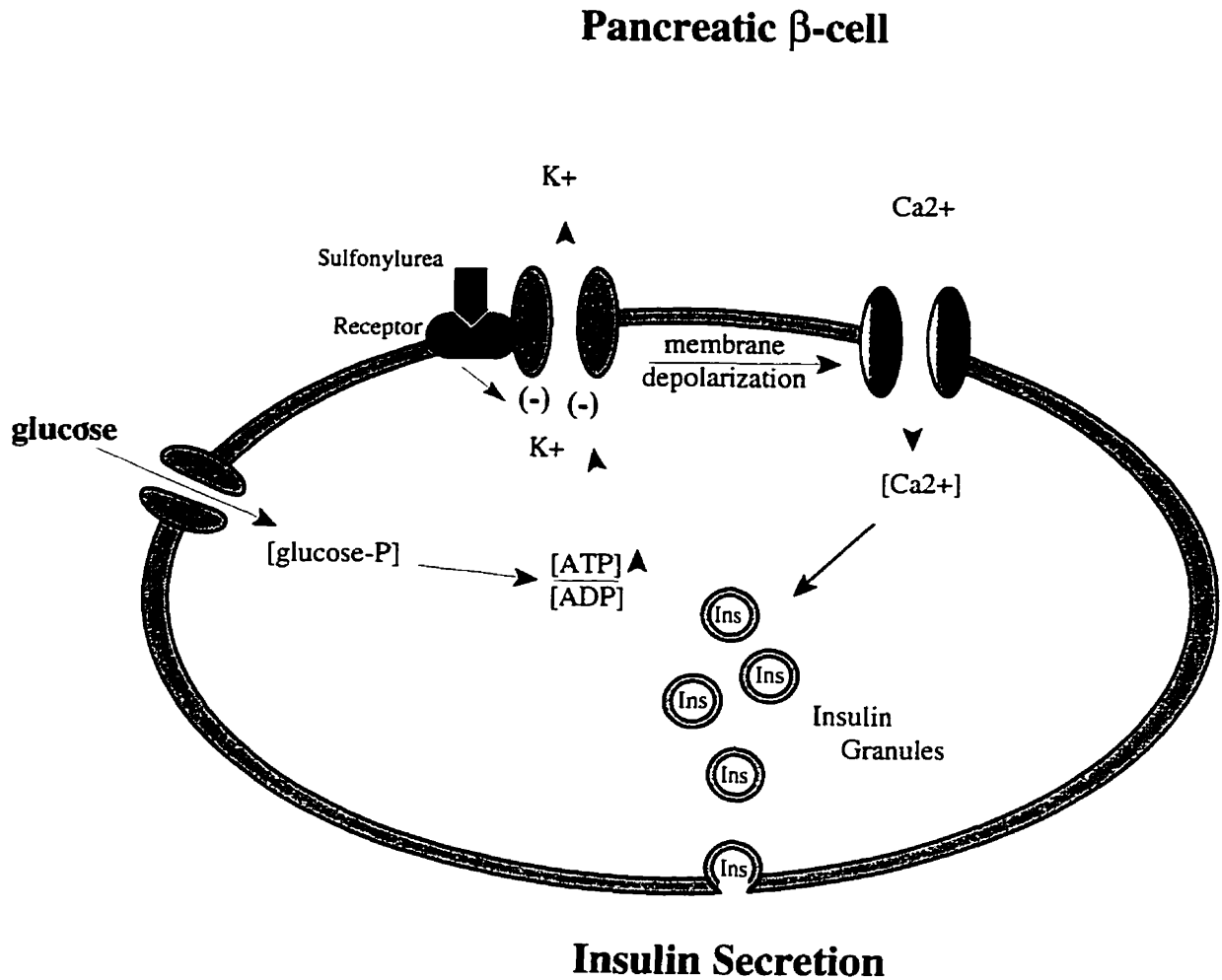

Glucose is transported into β -cells and metabolized increasing the ATP/ADP ratio which inhibits the ATP-sensitive K^+ channels causing depolarization of the plasma membrane. This results in opening of voltage-sensitive Ca^{++} channels, entry of Ca^{++} ions and exocytosis of insulin. Sulfonylurea action involves inhibition of ATP-sensitive K^+ channels with the rest of the steps leading to insulin secretion as described above and in the text.

of glucose transporter proteins which, together with the enzyme glucokinase involved in glucose metabolism, sense the high blood glucose levels. Glucose is transported via GLUT 2 into the pancreatic β -cells where it is metabolized. The rate limiting step in its metabolism is the phosphorylation catalysed by glucokinase. Glycolysis and glucose oxidation increase the intracellular concentration of ATP and thus the ATP/ADP ratio which regulates the ATP-sensitive K^+ channels found at the β -cell plasma membrane. Under normal physiological circumstances these channels allow the exit of K^+ from the cytoplasm to the extracellular space. The ATP-sensitive channels are inhibited by ATP, the open state probability of the channels is decreased and therefore K^+ builds up inside the cells which leads to cell membrane depolarization. The change in membrane potential affects the voltage-sensitive Ca^{++} channels located at the plasma membrane. These Ca^{++} channels open and Ca^{++} flows into the cytoplasm from the extracellular space. The increased Ca^{++} levels result in exocytotic events and insulin release.

Sulfonylureas stimulate insulin secretion by the pancreas via a signalling pathway shown in Figure 2.2. Binding of sulfonylureas to sulfonylurea receptor results in modulation of the ATP-sensitive K^+ channels. The open state probability of the channel is reduced, and therefore the efflux of K^+ ions is inhibited. The events that follow are similar to those described above and result in insulin secretion.

Although the mechanism by which sulfonylureas act on β -pancreatic cells has been extensively studied, the mode and mechanism(s) of action of sulfonylurea compounds on peripheral tissues are not clear. Several possible mechanisms of peripheral sulfonylurea action are discussed in the following section.

2.4.3 Possible mechanism of action of sulfonylureas in peripheral tissues.

2.4.3.1 Effect of sulfonylureas on insulin binding and insulin receptor kinase activity.

In vivo and in vitro studies in humans and in animal models of diabetes have shown that sulfonylureas in peripheral tissues act both at the level of the insulin receptor (263) and at post-insulin receptor sites in various tissues (287).

There are some reports (279,286,325) showing that sulfonylureas have an effect on insulin receptor number and/or affinity in peripheral tissues of NIDDM patients which is correlated with the efficacy of these drugs. However, the same improvement in insulin binding after sulfonylurea treatment is not observed in all studies (300,326) and its relative importance is unclear. In vivo studies in NIDDM patients who were treated for 3 months with sulfonylureas showed no changes in the mean receptor concentration of either monocytes or erythrocytes (327). Muscle biopsies of NIDDM patients treated with gliclazide for 2 months showed no changes in insulin receptor number and no difference in basal and insulin-stimulated tyrosine kinase activity (303,328). Similarly subcutaneous fat biopsies of NIDDM patients treated with glyburide for 3 months showed no changes in insulin receptor number (329).

Contradictory results have also been observed in vitro. In 3T3-L1 adipocytes exposure to tolbutamide (1.5 mM) for 2-3 days resulted in an increase in insulin receptor number (150-250% of control) without any changes in the affinity of the receptor for insulin (298). Similar exposure (20-44h) of rat epididymal adipose tissue to tolazamide did not affect either insulin receptor number or affinity (300). Tolbutamide (3 mM) treatment of BC3H1 cells also had no effect on insulin binding (294). The reasons for the discrepancies observed both in vivo and in vitro studies are not clear and may be due to differences in experimental techniques, variations in the doses of the drugs used, differences in the patient populations or in the tissue culture system used. Overall, these data suggest that sulfonylureas in peripheral tissues act at a post binding step.

2.4.3.2 Effect on glucose transport and glucose transporters

Many in vitro studies of insulin target tissues have shown that sulfonylureas have a direct effect to increase glucose transport. The mechanism whereby sulfonylureas stimulate glucose transport is uncertain. One potential postreceptor mechanism of action of sulfonylureas is an effect on cellular glucose transporters. In rat adipocytes glyburide exposure for 48 h resulted in a potentiation of insulin-stimulated glucose transport which was correlated with a

potentiation of insulin-induced recruitment of glucose transporters from an intracellular microsomal pool to the plasma membrane as measured by cytochalasin B binding (330). The total cellular content of GLUT1 mRNA and protein levels was increased by tolazamide treatment in L6 cells (291). Similar increases in GLUT1 mRNA and protein levels were also seen in 3T3L1 adipocytes treated with tolbutamide (297) without any changes in GLUT4 mRNA or protein levels. The lack of change in GLUT4 levels was also evident in muscles from insulin resistant (high fat-high sucrose diet induced) rats that had been treated with glyburide for 10 days (331). Glimpiride, another sulfonylurea drug has been shown to directly stimulate glucose transport in insulin resistant rat adipocytes (induced by high glucose and high insulin) which was due to the stimulation of GLUT1 and GLUT4 glucose transporter translocation (332). Furthermore in that study it was suggested that the molecular site of glimepiride action is related to GLUT4 phosphorylation /dephosphorylation as glimepiride reduced the elevated GLUT4 phosphorylation observed in resistant adipocytes (332). The same group of investigators in more recent studies found correlations between sulfonylurea-induced stimulation of glucose transport and cAMP degradation/protein kinase A inhibition, and they proposed that the stimulation of glucose utilization by sulfonylureas is mediated by a decrease of cAMP-dependent phosphorylation of GLUT4 (333). In the study presented in the following chapter it was found that gliclazide and glyburide treatment of L6 muscle cells increases glucose transport by an apparently different mechanism; i.e. by increasing the GLUT1 transporter levels by a posttranslational mechanism that possibly involve the stabilization of this transporter at the plasma membrane.

2.4.3.3 Role of PKC in the sulfonylurea-induced increase in glucose transport

There are some reports suggesting that the action of sulfonylureas to increase glucose transport in peripheral insulin target tissues is mediated by the activation of PKC. Evidence comes from studies in which the glucose transport effects of glyburide and tolazamide in rat adipocytes were blocked by three different PKC inhibitors (staurosporine, H-7 and

sangivamycin) and by phorbol ester induced-downregulation of PKC (299). In BC3H1 and L6 muscle cells the tolbutamide- and glyburide-induced increase in glucose transport was blocked by staurosporine and PKC depletion (293,295). It is worth noting that in all these studies in which a PKC-mediated effect of sulfonylureas on glucose transport was observed the effect of sulfonylurea was more acute(4 hours) in contrast to the chronic effect (24-48 hours) of sulfonylureas on glucose transport seen in most studies.

2.5 SUMMARY

Sulfonylurea drugs have represented the backbone of oral hypoglycemic therapy in NIDDM for many years. These drugs act on the pancreas and increase the release of insulin contributing in this way to the reduction of blood glucose levels. In addition to these pancreatic effects sulfonylureas have been reported to act directly on peripheral insulin target tissues to stimulate the uptake of glucose (Figure 2.3). Furthermore additional direct effects of sulfonylureas which may reduce diabetic complications have been suggested in various studies. The mechanism of the pancreatic action of sulfonylureas involves binding of the drugs to specific sites on the β -cell plasma membrane, identified as sulfonylurea receptors, which leads to inhibition of K^+ ion efflux through ATP-sensitive K^+ channels, membrane depolarization and initiation of events resulting in insulin secretion. The mechanism however mediating the extrapancreatic action of sulfonylureas is not clear, and it is not known whether similar events that take place in β -cell also take place in peripheral tissues. Most likely the action of sulfonylureas in peripheral insulin target tissues is not mediated at the insulin receptor but at "postreceptor" sites. It is expected that progress in this field will lead to a full understanding of the effects and mechanism of action of sulfonylureas.

Figure 2.3 Action of sulfonylureas in NIDDM

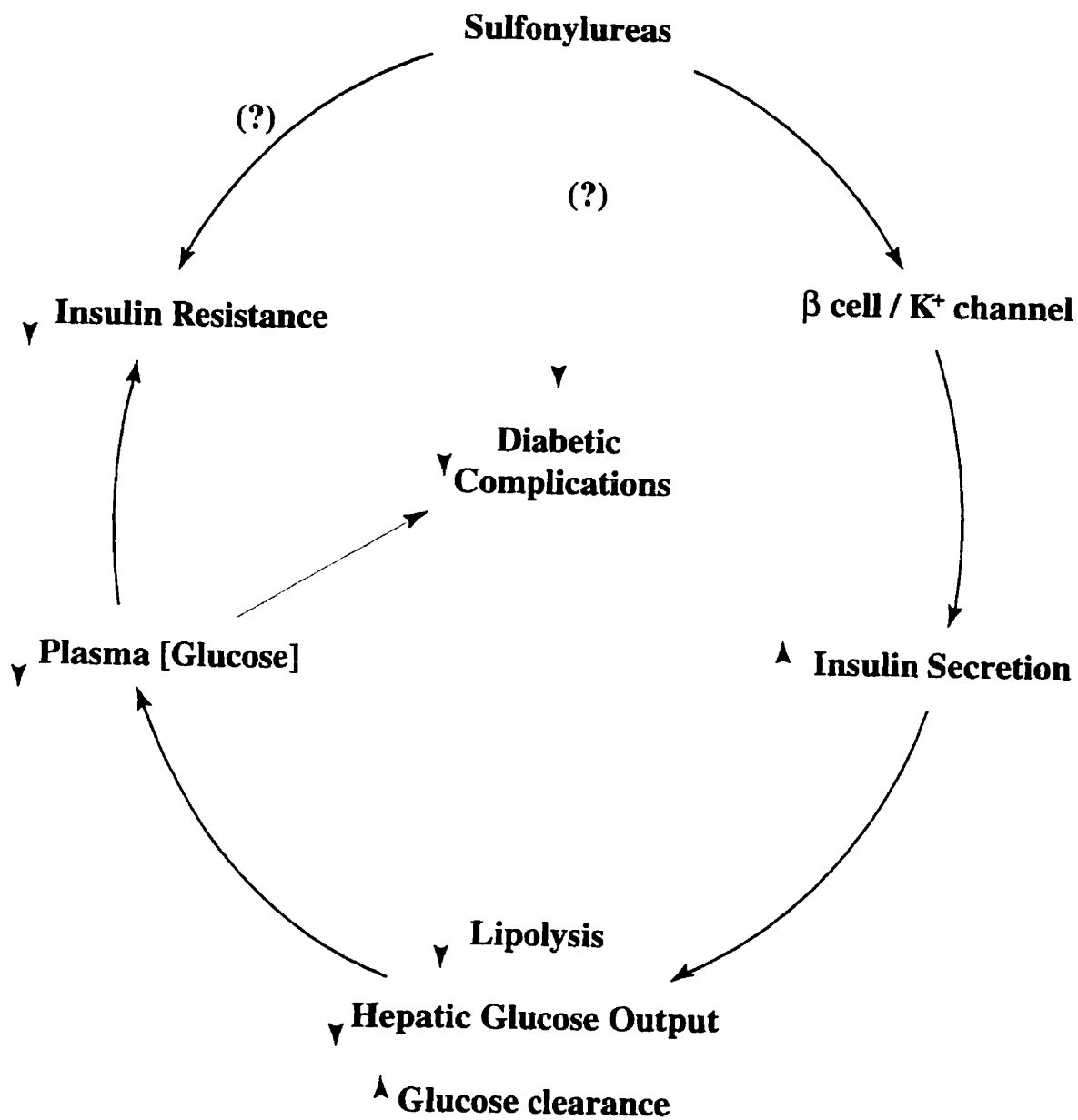

Sulfonylureas act on β -cell to increase insulin release, on peripheral tissues to ameliorate insulin resistance and may also have direct effects to reduce diabetic complications.

CHAPTER 3

EFFECTS OF THE SULFONYLUREAS GLICLAZIDE AND GLYBURIDE ON GLUCOSE TRANSPORT AND GLUCOSE TRANSPORTERS IN MUSCLE CELLS

3.1 ABSTRACT

Many studies suggest that sulfonylureas (SU) have direct extra-pancreatic actions. The action of gliclazide, a new SU, was examined and compared to that of glyburide in L6 myotubes, an in vitro model of skeletal muscle. Gliclazide and glyburide increased 2-deoxy-D-glucose (2DG) uptake in a time and dose-dependent fashion after 24 h to a maximum of 179% and 202% of basal levels respectively ($p < 0.001$). Acute (30 min) insulin (10^{-7} M) stimulated 2DG uptake to similar levels (203% of basal) but this effect was absent after maximum stimulation by SU. Sulfonylurea action did not require insulin and was not blocked by the protein synthesis inhibitor cycloheximide. To investigate the mechanism of stimulation of 2DG uptake, cells were fractionated and total, plasma membrane (PM) and internal membrane (IM) levels of glucose transporter (GLUT) isoforms were determined by immunoblotting. Both drugs significantly ($p < 0.05$) increased the total content (1.7 fold) and PM (1.8 fold) level of GLUT1 with no change in IM. Total content and PM levels of GLUT4 and GLUT3 did not change. It is concluded that the stimulation of glucose uptake in L6 cells by gliclazide and glyburide is not associated with a redistribution but rather an increase in total membrane content and PM level of GLUT 1 which is independent of protein synthesis. These data suggest a novel action of sulfonylureas to stabilize the GLUT1 protein at the plasma membrane.

3.2 INTRODUCTION

Although evidence exists supporting the extra-pancreatic actions of sulfonylureas this issue is still controversial and needs further clarification (247). Furthermore, the molecular mechanism of action of sulfonylurea compounds to increase glucose disposal by peripheral tissues is not known and it is not clear whether endogenous insulin is required. In in vitro studies, various sulfonylurea compounds; i.e., tolazamide, tolbutamide and glyburide, have been shown to increase glucose uptake in primary cell cultures (292,299,300) as well as different adipocyte (297,298) and muscle cell lines (291,293-295) as it is discussed in section 2.3.2. and shown in Table 2.2.

Gliclazide is a new, second generation sulfonylurea drug with a different structure (shown in Figure 2.1) and a prominent effect on first phase insulin release (248,273,276), that has not been studied extensively. In order to determine whether gliclazide has any unique and direct extra-pancreatic effect to stimulate glucose uptake, the effects of both gliclazide and glyburide on glucose uptake and glucose transporter distribution was examined in L6 skeletal muscle cells, an in vitro model of rat skeletal muscle discussed in section 1.5.

In this study, it is demonstrated that gliclazide and glyburide can act in a time- and concentration-dependent manner, independently of insulin to stimulate glucose transport in L6 myotubes. This action was associated with an increase in the plasma membrane levels of the GLUT1 glucose transporter isoform apparently mediated by a posttranslational mechanism.

3.3 MATERIALS AND METHODS

3.3.1 Materials

Alpha-minimum essential medium (α -MEM), fetal bovine serum (FBS) and antibiotics were obtained from Gibco (Burlington, ON, Canada). HEPES, bovine serum albumin (BSA), Tris base, protease inhibitors, 2-deoxy-D-glucose, cycloheximide and cytochalasin B were purchased from Sigma (St. Louis, MO). D-glucose, KCl, NaCl and CaCl₂ were from BDH (Toronto, ON, Canada). Dimethyl sulfoxide (DMSO) and MgSO₄ were from Anachemia

(Mississauga, ON, Canada). 2-Deoxy-[³H]-glucose was purchased from New England Nuclear (Boston, MA) and human insulin was a gift from Eli Lilly (Indianapolis, IN). Gliclazide was kindly provided by Servier (Neuilly-Sur-Seine Cedex, France) and Glyburide by Hoechst (Varenes, QC, Canada). Rabbit anti-rat GLUT1 and GLUT4 antibodies were purchased from East Acres Biologicals (Southbridge, MA). Rabbit anti-mouse GLUT3 was a kind gift from Dr. I. Simpson (NIH, Bethesda, MD). [¹²⁵I]-protein A was purchased from ICN (Costa Mesa, CA).

3.3.2 Cell cultures and Drug treatment.

L6 cells (kindly provided by Dr. A. Klip) were grown and maintained in a-MEM containing 5 mM glucose, 2% (v/v) FBS and 1% (v/v) antibiotic-antimycotic solution (final concentrations: 100 units/ml penicillin, 100 µg/ml streptomycin, 250 ng/ml amphotericin-B) in a humidified atmosphere of 5% CO₂:95% air at 37°C. The cells were fed fresh medium every 48 h and were allowed to reach confluence, align and fuse into myotubes before being used for experiments. All experiments were conducted on cells below passage 12. The cells were grown in 6 well plates for glucose transport measurements or in 15 cm diameter dishes for preparation of membrane fractions for 7 days.

In all experiments the cells were incubated in medium containing 15 mM D-glucose for a total of 48 h before the glucose uptake assay or the preparation of the membrane fractions. These levels of glucose mimic those commonly found in individuals with poorly controlled NIDDM and it has been shown to lower plasma membrane GLUT1 levels in L6 cells (334).

Gliclazide and glyburide stock solutions were prepared using DMSO and subsequently diluted with α-MEM before application to the cells. The final concentration of gliclazide or glyburide in the incubation medium and the time of incubation are indicated in each figure. In the untreated, control cells the same volume of diluent was added to match the DMSO concentrations in the drug-treated cells. To determine the acute insulin response, the drug-treated and control cells were incubated with 10⁻⁷ M insulin for 30 min before the glucose uptake assay.

3.3.3 Glucose uptake (2-deoxyglucose uptake assay).

At the end of the incubation of the cells with the different stimuli, the medium was removed, the cells were rinsed twice with HEPES-buffered saline solution (HBS) (140 mM NaCl, 5 mM KCl, 20 mM HEPES, 2.5 mM MgSO₄, 1mM CaCl₂, pH 7.4) and subsequently glucose uptake was measured in HBS containing 10 μM 2-Deoxy-D-[³H]-glucose (1 μCi/ml) for 5 min at 22⁰C. It has been previously shown (220) and I confirmed in preliminary experiments (not shown) that the uptake of glucose in L6 skeletal muscle cells is linear for at least 30 min under basal and insulin-stimulated conditions. The glucose uptake assay was terminated by washing the cells 3 times with 3 ml of ice-cold 0.95% saline solution followed by solubilization of the cells with 0.05 N NaOH and radioactivity was determined by scintillation counting. For the non-carrier mediated glucose transport cytochalasin B (CB), a fungal alkaloid that binds to glucose transporters and blocks their glucose transport capacity, at final concentration 10 μM was used in parallel wells. Carrier-mediated glucose uptake was determined after subtraction of the non-specific (presence of CB) from the total (absence of CB) uptake. All experiments were assayed in triplicate and performed at least 4 times. Basal glucose uptake varied somewhat over the course of the entire study ranging from 5.3 to 17.2 pmol/mg/min. For each series of experiments the control and treated cells were assayed in parallel and the intraassay coefficient of variation was ≤7.1%.

3.3.4 Preparation of membrane fractions.

Cells grown in 15 cm diameter dishes were incubated in medium containing 15 mM glucose for 24 h followed by 24 h incubation in the same medium with or without 100 μM glyburide or 4 mM gliclazide. After this incubation period myotubes were gently scraped in their own incubation medium with a rubber policeman, centrifuged (700xg for 8 min) and placed on ice. All subsequent steps were done at 4⁰C. The cell pellet was resuspended in homogenization buffer (250 mM sucrose, 20 mM HEPES pH 7.4, 2 mM EGTA, 3 mM NaN₃ and freshly added protease inhibitors : 200 μM phenylmethylsulfonylfluoride (PMSF), 10 μM trans-epoxysuccinyl-L-leucyl amido [4-guanidino]butane (E-64), 1μM leupeptin, 1μM pepstatin A),

and homogenized with 20 strokes in a 40 ml glass Dounce type A homogenizer. The homogenate was centrifuged at 1,000 x g for 5 min. The pellet (P1) was re-homogenized and centrifuged at 1,000 x g for 5 min. The pellet (P2) was discarded and the supernatants SN1 and SN2 were pooled and an aliquot used to obtain total membranes (TM) by centrifugation at 177,000 x g for 60 min. The remaining supernatant (SN1 and SN2) was centrifuged at 31,000 x g for 60 min. The resulting supernatant (SN3) was used to collect internal membranes (IM) by centrifugation at 177,000 x g for 60 min (P4). The 31,000 x g pellet (P3) was gently rinsed without disturbing with homogenization buffer and then resuspended in the same buffer to a final volume of 3 ml using a Wheaton 5 ml teflon glass homogenizer. Pellet 3 was placed on a discontinuous sucrose gradient of 3 ml each of 32%, 40% and 50% (w/w) sucrose solution in 20 mM HEPES pH 7.4. The membranes banded on top of the 32% sucrose layer at the 32%/40% and at the 40%/50% sucrose interfaces were collected and pelleted. Membranes isolated atop the 32% sucrose layer are enriched in plasma membrane markers and therefore this fraction is denoted plasma membrane (PM). Membrane protein was determined by the Bicinchoninic acid method (335).

3.3.5 Immunoblotting.

Samples of total membranes, plasma membrane and intracellular membrane fractions were solubilized in electrophoresis sample buffer and separated by SDS-polyacrylamide gel electrophoresis. The samples were subsequently transferred electrophoretically to PVDF (polyvinylidene difluoride, BIORAD) membranes. The membranes were incubated for 1 h at room temperature with 3% (w/v) BSA in Tris-buffered saline containing 0.04% NP-40 (buffer A) and then incubated overnight at 4 °C with anti GLUT4 polyclonal antibody R820 (1:500 dilution), anti-GLUT1 polyclonal antibody (1:1000 dilution), or anti-GLUT3 antibody (1:500 dilution) in the same buffer. Primary antibodies were detected with 1 µCi/10 ml [¹²⁵I]-labelled protein A and were visualized by autoradiography using Kodak XAR-5 film and quantified by laser scanning densitometry.

Statistical analysis

Results are presented as mean \pm SEM. The significance of the differences between groups was determined using analysis of variance (ANOVA).

3.4 RESULTS

3.4.1 Time-dependent effect of gliclazide and glyburide on glucose uptake.

Incubation of L6 myotubes with 4 mM gliclazide (Figure 3.1.A) or 100 μ M glyburide (Figure 3.1.B) resulted in the stimulation of glucose uptake in a time-dependent manner. Both sulfonylureas increased glucose uptake in L6 cells to significant levels within 12-24 h of incubation. Maximum stimulation by both sulfonylureas was observed by 24 h and in all subsequent experiments 24 h incubation with the two agents was used. It should be noted that the non-carrier mediated glucose uptake determined as cytochalasin B non-inhibitable uptake was less than 5% of the total uptake and was not affected by drug treatment.

3.4.2 Concentration-dependent effect of gliclazide and glyburide on glucose uptake

The effect of gliclazide and glyburide on glucose uptake was dose-dependent (Figure 3.2.A and 3.2.B). Significant increases in glucose uptake were seen with 4 mM gliclazide (17.2 ± 1.2 pmol/mg/min vs control 11.0 ± 0.8 pmol/mg/min, $p < 0.05$) and 50 μ M glyburide (15.7 ± 1.1 pmol/mg/min vs control 12.5 ± 0.8 pmol/mg/min, $p < 0.05$). Maximum stimulation by gliclazide (19.7 ± 1.5 pmol/mg/min $p < 0.001$) and glyburide (25.3 ± 2.6 pmol/mg/min ($p < 0.001$)) was reached at concentrations of 8 mM and 500 μ M respectively. Higher concentrations, up to 10 mM gliclazide and 1000 μ M glyburide did not result in any greater stimulation of glucose uptake (data not shown). To determine whether the "hyperglycemic" medium containing 15 mM glucose influenced this action, the experiments were repeated using 5 mM glucose containing medium. The stimulation of glucose transport above control values induced by gliclazide and glyburide treatment was of similar magnitude (data not shown) suggesting that glycemia does not influence the net effect of the drugs. Additionally, the presence of the two sulfonylureas did

Figure 3.1 Effect of gliclazide (A) and glyburide (B) on 2-deoxyglucose uptake in L6 myotubes. Time-course

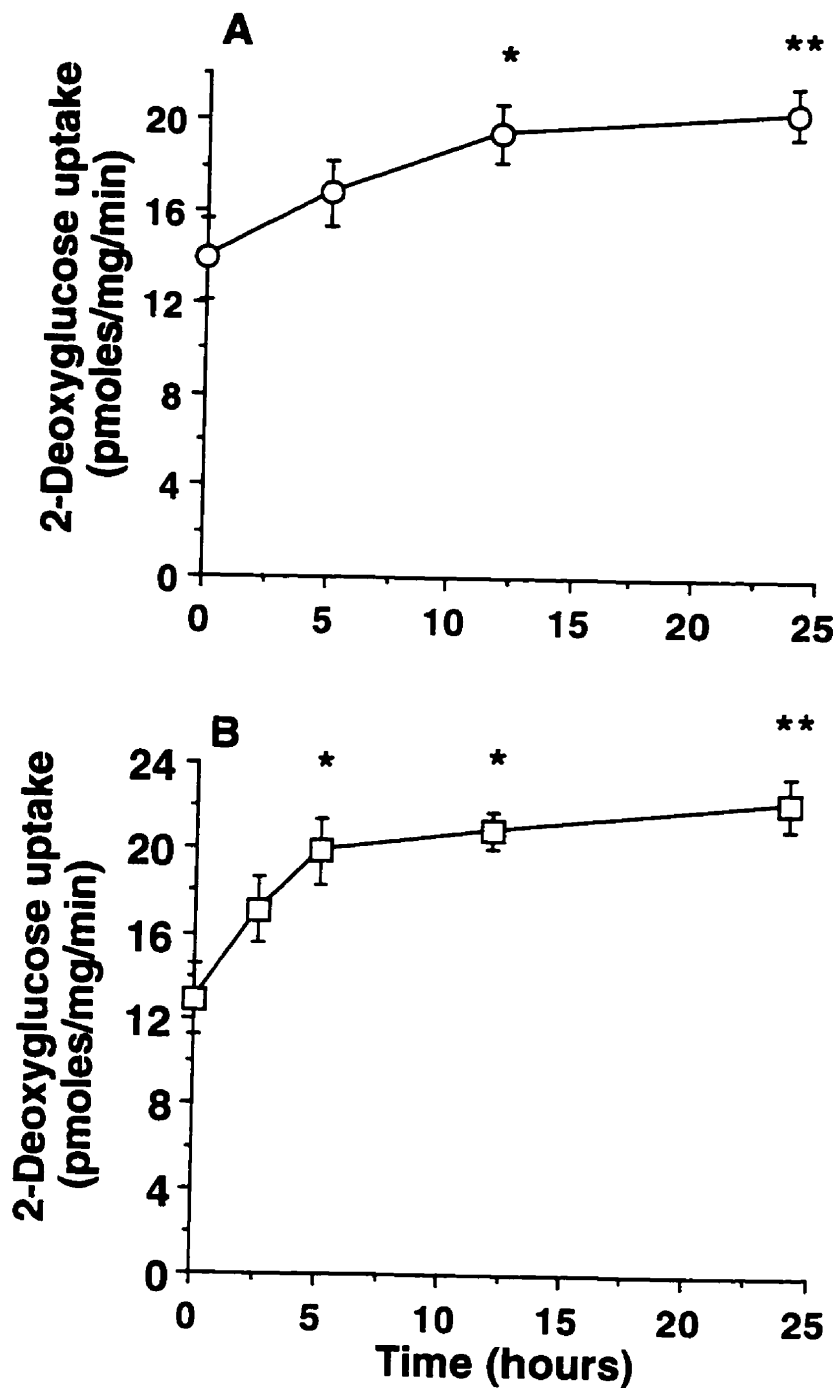

L6 myotubes were incubated in a-MEM containing 15 mM glucose and 4 mM gliclazide (A) or 100 μ M glyburide (B) at 37 $^{\circ}$ C for the time indicated. At the end of the incubation period, glucose uptake was determined as described in Materials and Methods. The results (mean \pm SE) are from 4-9 independent experiments each performed in triplicate. (*, $p < 0.05$, **, $p < 0.001$). Note that both sulfonylureas required long incubation time to increase glucose uptake.

Figure 3.2 Effect of gliclazide (A) and glyburide (B) on 2-deoxyglucose uptake in L6 myotubes. Dose-response

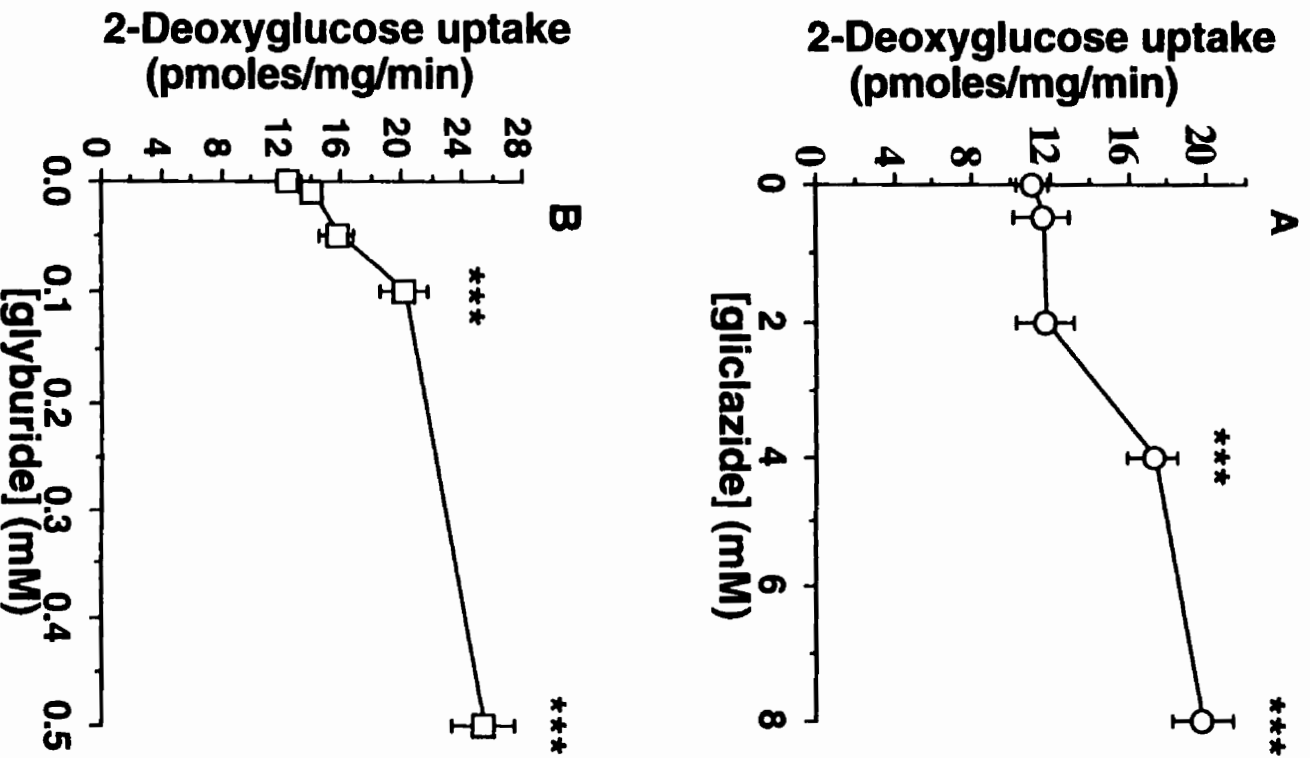

Cells were incubated with the indicated concentrations of gliclazide and glyburide for 24 h at 37 °C followed by assay of glucose uptake. The results shown are the mean \pm SE of 4-9 independent experiments each performed in triplicate. (***, $p < 0.001$). Note that gliclazide stimulated glucose uptake at concentrations much higher than that of glyburide.

not alter the level of glucose in the medium (as measured by the Beckman method) throughout the duration of the incubations. Cell viability, as measured by trypan blue staining, was not affected by drug treatment.

3.4.3 Effect of sulfonylurea treatment on insulin-stimulated glucose uptake

To investigate whether sulfonylurea action to increase glucose uptake affects the acute insulin-induced increase in glucose uptake the interaction between acute insulin exposure and sulfonylurea treatment was examined (Figure 3.3). Insulin was added to the cells for 30 min before the measurement of glucose uptake in the control and drug pre-treated cells. Drug treatment was continued in parallel with insulin treatment. Insulin alone at 10^{-7} M for 30 min resulted in a significant increase in glucose uptake ($203 \pm 10.43\%$ of control, $p < 0.001$). Treatment of myotubes for 24 h with gliclazide (8 mM) or glyburide (100 μ M) alone or with insulin added for the final 30 min resulted in a significant increase in glucose uptake above basal values. No statistically significant differences were observed between the responses of cells treated with insulin or sulfonylurea alone and those treated with both agents (Figure 3.3). Thus there was no apparent additivity or potentiation of insulin response when combined with sulfonylurea and the sulfonylurea actions did not require the presence of insulin. It should be noted that the cells were cultured and exposed to the sulfonylureas in the presence of 2% (v/v) FBS which may contain a small amount of insulin. Thus the concentration of insulin in the FBS employed (Gibco Lot No. 42N7125) was measured by radioimmunoassay and was 30 pM resulting in a final concentration of 0.6 pM in the medium. Although this concentration of insulin does not appear to have acute effects on glucose transport or transporters in L6 cells ((220) and data not shown) it could not be ruled out that this marginal amount of insulin was required to observe the effects of the sulfonylurea compounds. Thus in separate experiments L6 cells were exposed to 4 mM gliclazide or 100 μ M glyburide in culture medium in the absence of FBS for 24 h. The sulfonylureas increased glucose uptake to a similar extent, 153% (gliclazide) and 185% (glyburide) of control.

Figure 3.3 Effect of sulfonylurea treatment on basal and insulin-stimulated glucose uptake

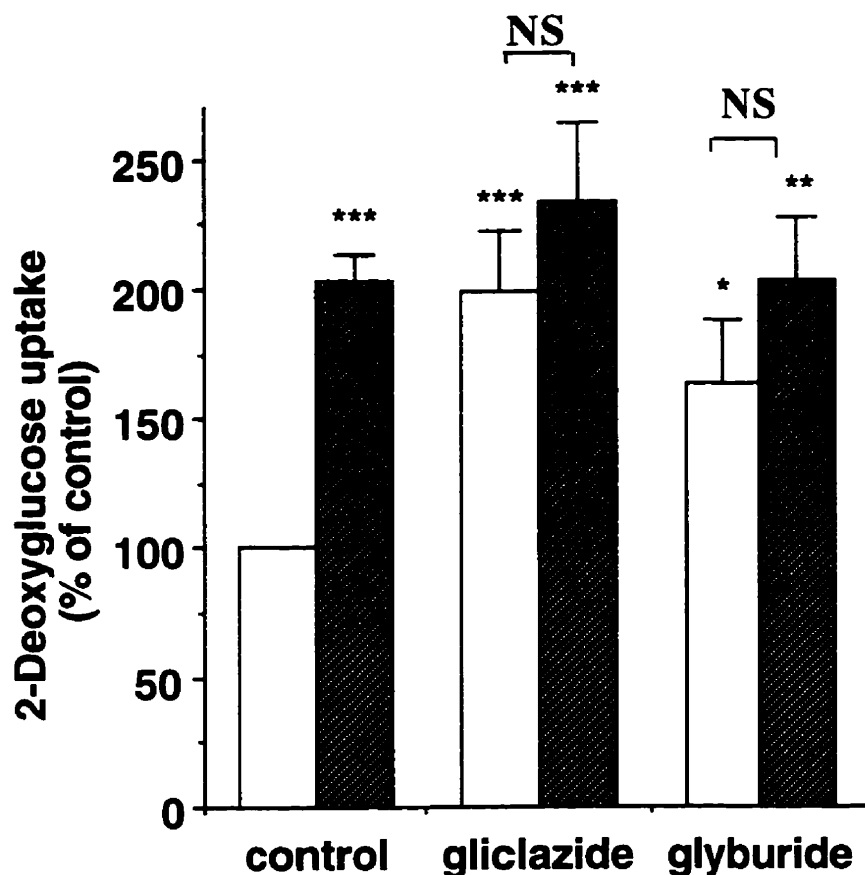

After 24 h treatment with sulfonylureas (as described in the legend to Figure 3.1) the myotubes were incubated with (shaded bars) or without (open bars) 10^{-7} M insulin for 30 min followed by assay of glucose uptake. The results shown are the mean \pm SE of 6-7 independent experiments performed in triplicate. *, $p < 0.05$, **, $p < 0.01$, ***, $p < 0.001$ all compared to untreated control. NS, not significant. Note that there was no additivity or potentiation of insulin response when combined with sulfonylureas.

3.4.4 Effect of cycloheximide on gliclazide and glyburide-stimulated glucose uptake

The relatively long incubation required to observe a significant response of the cells to gliclazide or glyburide (Figure 3.1) suggested that the two agents might induce the synthesis of a protein relevant for the stimulation of glucose uptake. To test this hypothesis the effect of the two agents in the presence of 1 $\mu\text{g/ml}$ cycloheximide (CHX), an inhibitor of protein synthesis was examined. Cycloheximide alone decreased the basal glucose uptake to a value of $71\pm 15.3\%$ of control ($p=0.143$) in 24 h. The stimulation of glucose uptake was $175\pm 17.8\%$ and $179\pm 21.4\%$ of control in the absence of cycloheximide with 8 mM gliclazide and 100 μM glyburide respectively, and a stimulation of similar magnitude, $153\pm 25\%$ and $157\pm 41\%$ of control (without CHX) was found in the presence of the drugs co-incubated with 1 $\mu\text{g/ml}$ of cycloheximide (Figure 3.4). This concentration of cycloheximide has previously been demonstrated to effectively block protein synthesis over 24 h in L6 cells as measured by ^{35}S -methionine incorporation into protein (252), which was confirmed in the present study by measurements of ^3H -leucine incorporation (data not shown). Thus, although the basal glucose uptake was partially inhibited by cycloheximide, the increase in glucose uptake induced by gliclazide and glyburide was not prevented. These results suggest that the increase in glucose uptake induced by gliclazide and glyburide is not dependent on protein synthesis.

3.4.6 Effect of gliclazide and glyburide on glucose transporter levels and distribution

To investigate the mechanism of action of the sulfonylureas the effect of gliclazide and glyburide on glucose transporter levels and their subcellular distribution was examined. Total membranes, internal membranes and plasma membranes from control and gliclazide- or glyburide-treated myotubes were prepared as described in Methods. The proteins in each fraction were separated by SDS-PAGE, transferred to PVDF membranes and examined by immunoblotting with specific antibodies against the different glucose transporter isoforms. A representative western blot is shown in Figure 3.5.

Figure 3.4 Effect of cycloheximide (CHX) on basal and gliclazide or glyburide-stimulated glucose uptake in L6 myotubes

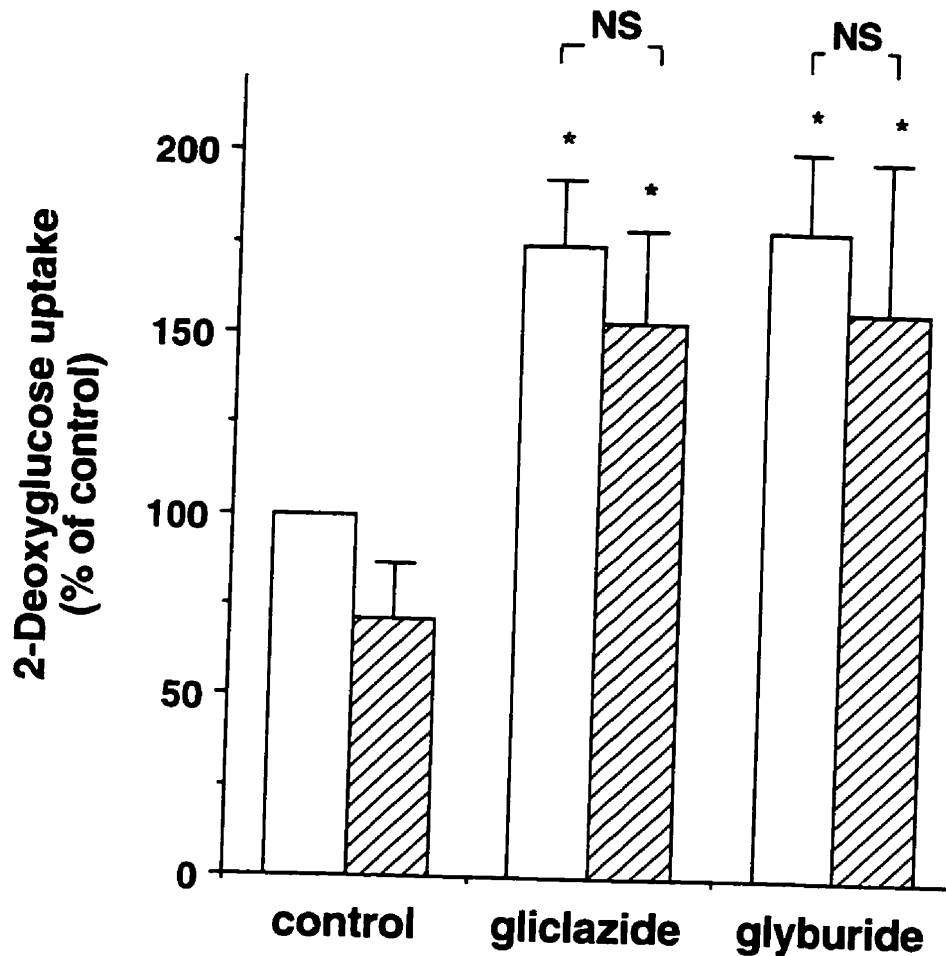

The cells were incubated with 8 mM gliclazide or 100 μ M glyburide with (hatched bars) or without (open bars) 1 μ g/ml CHX for 24 h. Control cells were also incubated with or without 1 μ g/ml CHX under exactly the same conditions. The results are the mean \pm SE of 4-7 independent experiments performed in triplicate. *, $p < 0.05$, compared to untreated control. NS, not significant. Note that cycloheximide did not affect the response of the cells to sulfonylureas used.

Figure 3.5 Effect of gliclazide and glyburide on the levels and distribution of glucose transporters in L6 skeletal muscle cells

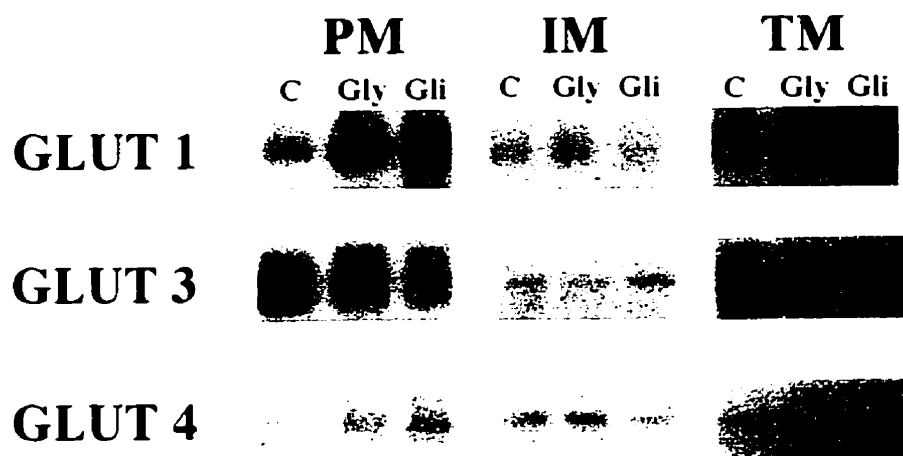

L6 myotubes were cultured and treated as described in the legend to Fig. 3.1 with 4 mM gliclazide (Gli) or 100 μ M glyburide (Gly) for 24 h. At the end of this incubation total membrane (TM), internal membrane (IM) and plasma membrane fractions from L6 myotubes were prepared as described in Materials and Methods and immunoblotted using the antibodies against the different glucose transporter isoforms. Results shown are from a representative of 8 separate experiments. The relative intensities of the bands were determined by laser densitometry and corrected for protein. The values are expressed in arbitrary units relative to control=1, and were: GLUT1-PM, Gly 2.9, Gli 3.1; IM, Gly 1.0, Gli 0.7; TM, Gly 2.0, Gli 1.6; GLUT3-PM, Gly 1.0, Gli 0.8; IM, Gly 0.6, Gli 0.6; TM, Gly 0.9, Gli 0.6; GLUT4-PM, Gly 1.4, Gli 1.6; IM, Gly 1.2, Gli 0.6; TM, Gly 2.0, Gli 1.0.

The results of 8 independent experiments (expressed in arbitrary densitometric units, mean \pm SE, and normalized for control=1) demonstrated significant increases in total membrane GLUT1 levels with both gliclazide and glyburide treatment (1.66 \pm 0.24 and 1.74 \pm 0.09 fold respectively compared to control untreated cells ($p < 0.05$)) (Figure 3.6). No significant changes in the levels of GLUT4 were seen with gliclazide or glyburide treatment in total membranes while the levels of GLUT3 show a small but significant decrease in this fraction only in response to gliclazide (Figure 3.6). Gliclazide and glyburide significantly increased the GLUT1 levels in the plasma membrane fraction (1.80 \pm 0.33 and 1.81 \pm 0.32 fold compared to control respectively ($p < 0.01$)) (Figure 3.7). No significant changes in the levels of GLUT3 and GLUT4 glucose transporter isoforms were observed in the plasma membrane fraction in response to sulfonylurea treatment (Figure 3.7). No changes were seen in the internal membrane fraction in GLUT1 transporters but there was an apparent decrease of GLUT3 levels in this fraction in response to both agents (Table 3.1). There was also a significant decrease in GLUT4 levels in the internal membrane fraction only after gliclazide exposure (Table 3.1).

3.4.7 Effect of cycloheximide on glyburide-induced increase in plasma membrane GLUT1

The extent of the specific increase in plasma membrane levels of GLUT1 stimulated by the sulfonylureas was similar to that of glucose uptake and suggested that this transporter isoform was responsible for the observed increase in glucose uptake. To further investigate this correlation the effect of cycloheximide on the glyburide-induced increase in plasma membrane GLUT1 was determined. While 1 μ g/ml cycloheximide alone did not significantly alter the plasma membrane content of GLUT1 protein, exposure of cells for 24 h to 100 μ M glyburide resulted in a similar fold increase (expressed in arbitrary densitometric units, mean \pm SE, and normalized for control=1) in plasma membrane GLUT1 in the absence (2.81 \pm 0.11) and presence (2.82 \pm 0.23) of cycloheximide (Figure 3.8) ($p < 0.001$ for both compared with control). Total membrane GLUT1 levels were not significantly changed in the presence of

Figure 3.6 Effect of gliclazide and glyburide on the total levels of glucose transporters in L6 skeletal muscle cells

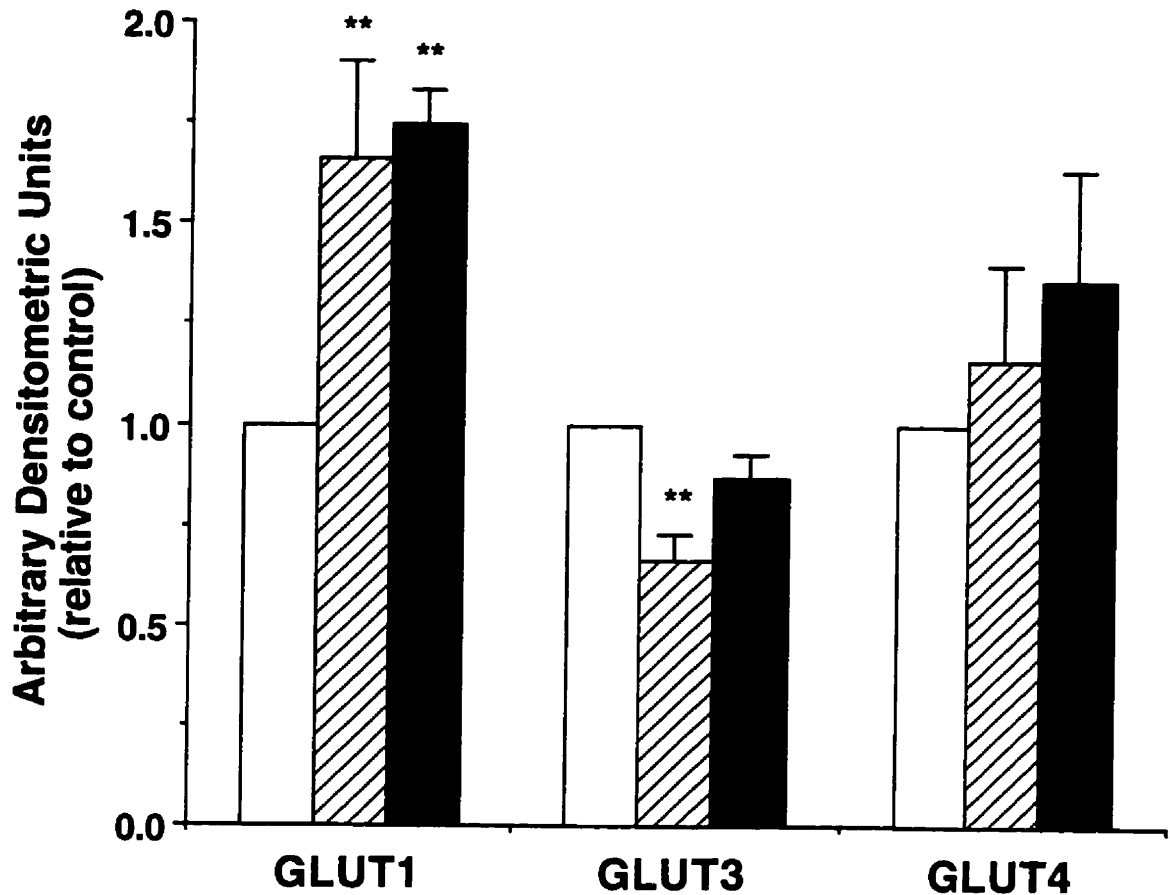

Total membranes from control (open bars), gliclazide (hatched bars) or glyburide (shaded bars) treated cells were prepared and immunoblotted using the different anti-glucose transporter antibodies as described in Methods. The results shown are the mean \pm SE of 8 independent experiments. Gliclazide and glyburide caused a significant increase in total membrane levels of GLUT1, 1.66 ± 0.24 and 1.74 ± 0.09 fold respectively compared to untreated control cells. **, $p < 0.01$. Note that GLUT 4 levels did not change and that there was a decrease in GLUT 3 levels with gliclazide only.

Figure 3.7 Effect of gliclazide and glyburide on the plasma membrane levels of glucose transporters in L6 skeletal muscle cells

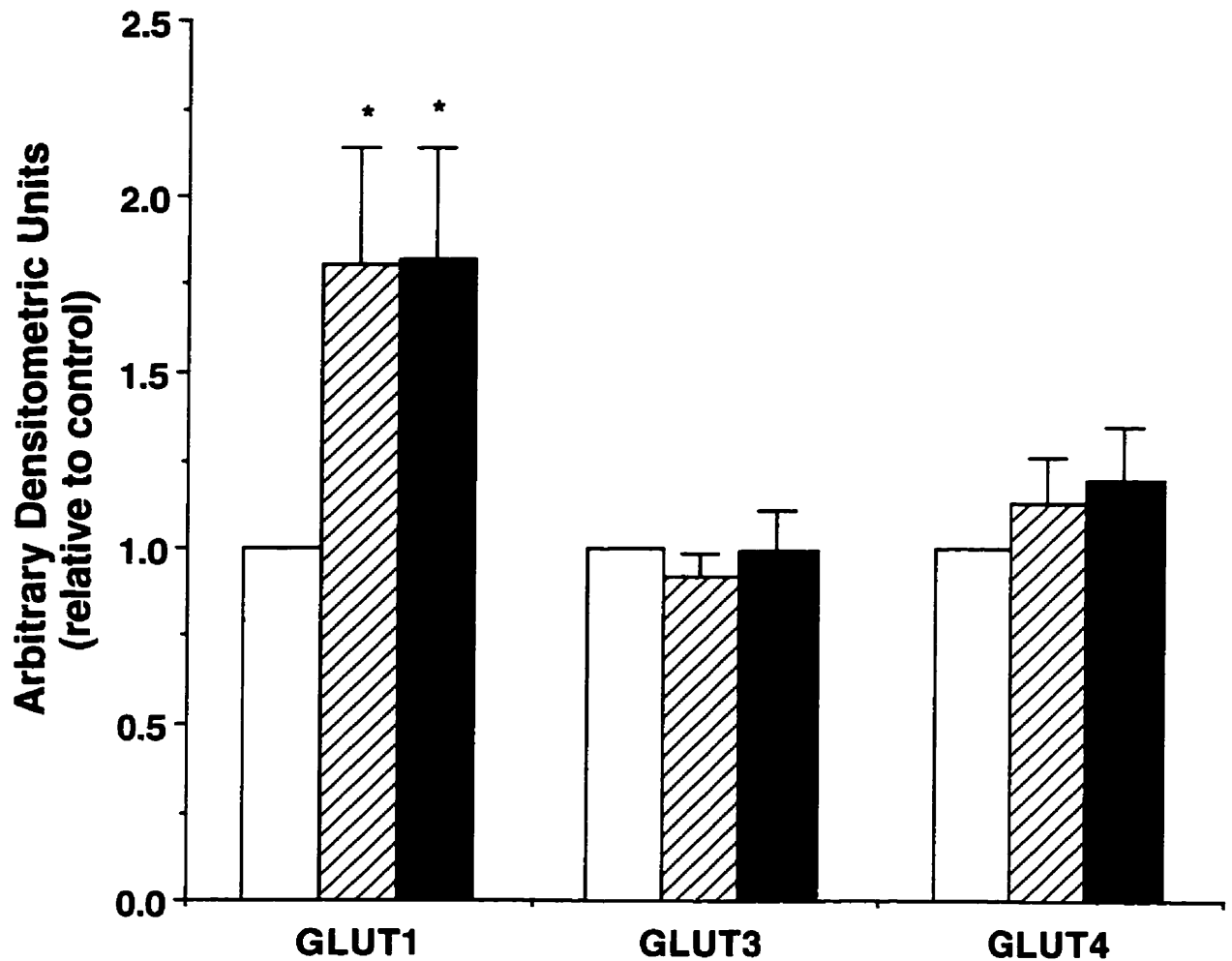

Plasma membranes (PM) from control (open bars), gliclazide (hatched bars) or glyburide (shaded bars) treated L6 cells were prepared and immunoblotted using specific anti-glucose transporter antibodies as described in Methods. The results shown are the mean \pm SE of 8 independent experiments. *, $p < 0.05$ compared to untreated control. Note that GLUT1 levels were significantly increased with both sulfonylureas while no significant changes were observed in GLUT3 and GLUT4 levels.

Table 3.1 Effect of gliclazide and glyburide on the internal membrane levels of glucose transporters in L6 myotubes.

Internal membranes were prepared from control, gliclazide- or glyburide-treated cells and immunoblotted using the different anti-glucose transporter antibodies as described in Methods. The results shown are mean \pm SE of 8 independent experiments. For each experiment values were normalized with respect to control untreated cells. (NS: not significant, **, $p < 0.01$, ***, $p < 0.001$). Note that there was a significant decrease in GLUT3 levels with both gliclazide and glyburide and a decrease in GLUT4 levels with gliclazide only while the levels of GLUT1 glucose transporter were not changed with any of the treatments.

Transporter Isoform	Control	Gliclazide	Glyburide
GLUT1	1	0.98 \pm 0.22 (NS)	0.99 \pm 0.10 (NS)
GLUT3	1	0.47 \pm 0.07 (***)	0.56 \pm 0.05 (**)
GLUT4	1	0.51 \pm 0.07 (***)	0.83 \pm 0.09 (NS)

Figure 3.8 Effect of cycloheximide (CHX) on basal and glyburide induced changes in plasma membrane and internal membrane levels of GLUT1.

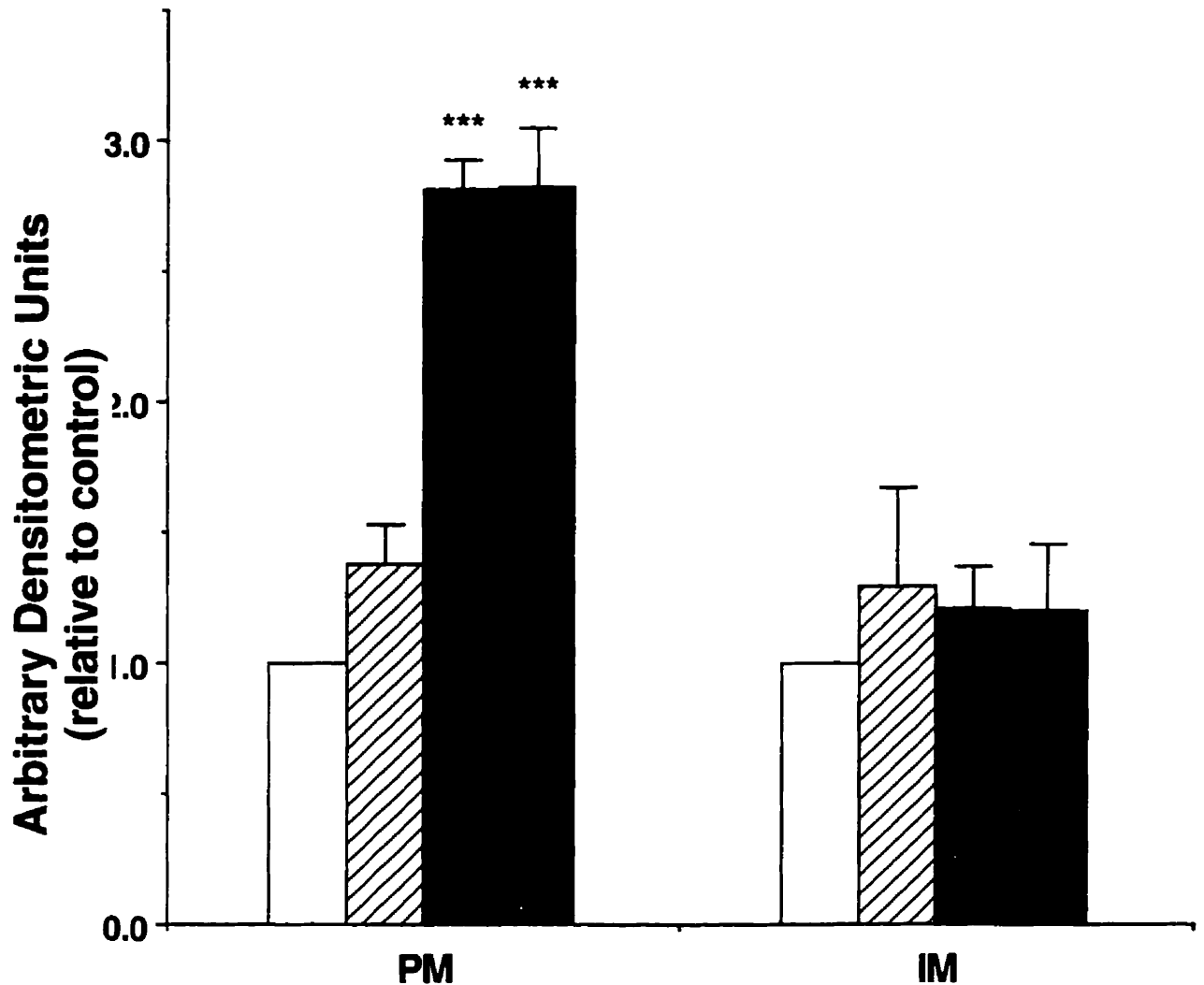

Myotubes were treated without (open bar) or with (cross-hatched bar) 1 $\mu\text{g/ml}$ CHX alone, with 100 μM glyburide alone (shaded grey bar) or the combination of CHX and glyburide (shaded black bar) for 24 h. Plasma membrane and internal membrane fractions were prepared and immunoblotted with anti-GLUT1 antibody as described in Methods. Results are the mean \pm SE of 3 experiments, each performed in duplicate and normalized to control = 1.0. Glyburide treatment resulted in a significant increase in plasma membrane GLUT1 content in the absence, 2.81 ± 0.10 , and the presence, 2.82 ± 0.23 , of CHX. CHX alone did not alter plasma membrane GLUT1 level and there were no significant changes in internal membrane GLUT1.***, $p < 0.001$.

cycloheximide (arbitrary densitometric units: 1.08 ± 0.23 compared to control). Also internal membrane levels of GLUT1 were not significantly altered by any of these treatments.

3.5 DISCUSSION

The results of the present study show that the sulfonylureas gliclazide and glyburide have a direct effect to stimulate glucose uptake in cultured L6 skeletal muscle cells. This action is dose- and time-dependent requiring several hours of exposure to the drugs. Previous *in vitro* studies with sulfonylureas have yielded in general two patterns of response; that is, an insulin-independent stimulation of glucose uptake (293,294) or a potentiation of insulin-stimulated glucose uptake with no effect on basal rates (291,300). Thus, in freshly isolated rat adipocytes, both a potentiation of acute insulin-stimulated glucose uptake by glyburide (301) and an acute (30 min) insulin-independent stimulation of glucose uptake by tolbutamide and glyburide (299) have been reported. In cultured 3T3-L1 adipocytes tolbutamide increased basal glucose uptake after prolonged exposure, similar to the results presented here (297). In cultured BC3H1 myoblasts (293) and in aligned but not fully differentiated L6 muscle cells (295) glyburide acutely (30 min) stimulated glucose uptake independently of insulin. Similar to the results presented here long term incubation with tolbutamide, glipizide and glyburide increased the basal glucose uptake in BC3H1 myoblasts in the absence of insulin (294). In fully differentiated L6 myotubes Wang and colleagues (291) reported that chronic treatment (22 h) with tolazamide increased only insulin-stimulated glucose uptake with no effect on basal. Thus the variable effects may depend, at least in part on the tissue type and the culture model system used, as well as possibly on the specific drug employed.

In this study a new agent, gliclazide, which has a somewhat different structure and has been suggested to preferentially stimulate the first phase of insulin release (273,276) was examined. Comparison of its actions in L6 myotubes with glyburide did not reveal any significant differences other than the concentrations required to stimulate glucose uptake. Interestingly there was a 16 fold higher concentration necessary to achieve maximum effects with gliclazide (8 mM versus 500 μ M) compared to glyburide consistent with the ratio of the doses

used in vivo to treat human subjects with NIDDM (80 mg tablet of gliclazide versus 5 mg tablet of glyburide).

The investigations presented here into the mechanism of the stimulatory effect of the sulfonylureas revealed that the increased glucose uptake was associated with a significant increase in total and plasma membrane GLUT1 protein without a change in the internal membrane GLUT1 levels. Furthermore, there were no substantial changes observed in total or plasma membrane GLUT4 or GLUT3. It was also found that cycloheximide while it inhibited protein synthesis did not inhibit these actions, indicating that new protein synthesis was not required. The results of Tordjman and colleagues of chronic tolbutamide action in 3T3-L1 adipocytes are very similar to these data (297). Chronic sulfonylurea exposure increased glucose uptake and total GLUT1 protein expression in these cells but did not alter total GLUT4. In addition GLUT1 steady state mRNA levels were increased. This suggested the possibility of increased gene expression and transcription. However the effects of protein synthesis inhibitors or transcriptional inhibitors were not examined. Furthermore in that study membrane fractionation was not performed and the distribution of glucose transporters was not examined. In differentiated L6 muscle cells Wang and colleagues reported that the sulfonylurea tolazamide increased total GLUT1 protein and GLUT1 steady state mRNA levels after 22 h (291). It is not clear why at the same time basal glucose uptake was not found to be increased in that study. The fact that the enhanced basal glucose uptake is associated with an effect on GLUT1 may explain some of the variable results using different models since the expression of GLUT1 in vivo (e.g. freshly isolated adipocytes) and in cultured cells may be different (336). The results presented here are supported by in vivo data obtained in high sucrose and fat diet-induced insulin resistant rats treated for 10 days with glyburide (331). An improvement in basal muscle glucose uptake after glyburide treatment was observed without any changes in total membrane GLUT4 content. Similarly, GLUT4 mRNA and protein levels were not changed in skeletal muscle of NIDDM patients treated with gliclazide for 8 weeks (337). GLUT1 was not examined in any of these in vivo studies. Taken together, the correlation of the increase in both glucose uptake and plasma membrane GLUT1 content and the lack of inhibition of both effects by cycloheximide strongly

support the notion that the sulfonylurea-stimulated increase in GLUT1 mediates the stimulation of glucose uptake. However the possibility that small simultaneous changes in glucose transporter intrinsic activity may have contributed cannot be excluded.

The observations of the present study showing no change in the distribution of GLUT1 and no inhibitory effect of cycloheximide suggest that the increase in plasma membrane GLUT1 is not due to translocation of transporters from intracellular stores or new protein synthesis. The increase in the number of glucose transporters may be due to a prolongation of their half-life. The data suggest that the sulfonylureas may cause a decrease in GLUT1 degradation and a preferential stabilization of the protein at the plasma membrane. In this context Gorray (296) reported that glyburide inhibits protein degradation in L6 skeletal muscle cells within 2-6 h. The results presented in this study indicate that there is likely some specificity associated with this action. It is also possible that the stabilization of GLUT1 at the plasma membrane may not be associated with inhibition of degradation. Total GLUT 1 levels did not change in the presence of cycloheximide suggesting that GLUT1 has a long half life (also supported by studies in 3T3 L1 adipocytes where GLUT1 half life was found to be 19h (338)), and that longer incubation with cycloheximide is required to see a decrease. Therefore, the increase in plasma membrane GLUT1 levels with sulfonylureas may be due to inhibition of GLUT1 internalization or acceleration of GLUT1 recycling which may or may not be associated with inhibition of degradation. It is also possible that GLUT1 transporters are recruited to the plasma membrane from another intracellular storage pool that is not identified in the present study. Further experiments in the future are needed to be done to determine the contribution of all the above possibilities in the increased plasma membrane GLUT1 levels in response to sulfonylureas (see section of overall discussion for future directions).

The acute effect of insulin on glucose uptake after exposure to the sulfonylureas was also studied. The relative effect of insulin appeared blunted but the absolute maximum transport rates were not different. The acute effect of insulin in L6 myotubes is associated with translocation of all three glucose transporters GLUT1, GLUT3 and GLUT4 from an internal pool to the plasma membrane (339,340). The already enhanced plasma membrane GLUT1 and

the reduced internal membrane pool of both GLUT3 and GLUT4 may explain in part the poor response to insulin after chronic exposure to the sulfonylureas. The significance of the decrease in the internal membrane compartment of GLUT3 and GLUT4 and the small decrease in total membrane GLUT 3 in response to gliclazide remains to be determined.

The mechanism of the peripheral actions of the sulfonylureas is not known. Some investigators have demonstrated the activation of protein kinase C by glyburide which correlated best with the more rapid effects observed (293,299). Davidson (295) demonstrated that in aligned L6 myoblasts glyburide-stimulated glucose uptake was inhibited by both cycloheximide and H7 and thus appeared to require protein synthesis and to be mediated by the activation of protein kinase C. In BC₃H1 myoblasts PKC activation was also observed in response to the sulfonylureas (293). In contrast, the long term action of gliclazide or glyburide could not be inhibited with the protein kinase C inhibitors staurosporine or H7 (data not shown). The reasons for these different results are not clear but the present studies were conducted with differentiated L6 myotubes and under different culture conditions. It is possible that the state of cellular differentiation will influence the response to these drugs.

Another possible mechanism is that similar to their well documented effects in insulin secreting B-cells (312), the sulfonylureas act via closure of ATP-sensitive K⁺ channels in peripheral tissues. However, it has been difficult to document the existence of these channels in L6 myoblasts (295). Studies using the patch clamp technique suggest that ATP-sensitive K⁺ channels exist in frog (318), mouse (314,317,319) and human (320) skeletal muscle but have decreased sensitivity and different binding affinities for the sulfonylureas compared with these K⁺ channels in B-cells (314) as it is discussed in 2.4.1. In preliminary experiments it was found that the effects of the sulfonylureas on glucose uptake in L6 myotubes were not blocked by cromakalim (data not shown), a sulfonylurea antagonist which opens the ATP-sensitive K⁺ channels (341,342).

Finally the question of the relevance of these peripheral actions of sulfonylureas to in vivo glucose homeostasis is not yet answered. This study demonstrates that the ratio of drug concentrations used in vivo is similar to that found to exert these peripheral effects suggesting a

common mechanism. The relatively high concentrations required in vitro do not rule out in vivo relevance since in many tissue culture systems cells are less responsive to drug and hormone effects. This was observed in the case of the hypoglycemic agent metformin in L6 cells (343). For example the concentration of metformin required to see an effect on glucose transport in L6 cells was 0.8 - 2 mM (maximum stimulation of glucose transport was observed at 5 mM) which is much higher than the concentration of metformin found in the plasma of people treated with the drug (12-100 μ M) (250). Furthermore, it is not known whether sulfonylurea receptors are present in L6 cells. One possibility which would explain the higher concentrations required to see an effect in L6 cells might be a lower affinity of the sulfonylurea receptor or an isoform in these cells. On the other hand it is also possible that the higher concentration indicate a totally unrelated mechanism of action. Although in vivo studies are difficult to interpret because of simultaneous changes in either insulin and/or glucose concentrations, Hirshman and Horton found that several days of administration of glyburide to normal rats resulted in increased basal and insulin-stimulated glucose disposal under euglycemic clamp conditions (287).

3.6 CONCLUSIONS

From the results presented in this Chapter it is concluded that there is a direct effect of the sulfonylureas gliclazide and glyburide to enhance glucose uptake in L6 skeletal muscle cells in vitro independent of insulin, associated with an increased level of total and plasma membrane GLUT1. In addition there is no decrease in GLUT1 content of internal membranes. Thus, the mechanism appears to involve a stabilization of GLUT1 protein at the plasma membrane as new protein synthesis is not required and there is no translocation of GLUT1 from the internal to the plasma membrane compartment. The data strongly suggest that the increased number of plasma membrane GLUT1 glucose transporters is responsible for the sulfonylurea-stimulated increase in glucose uptake. Whether this direct effect contributes to the glucose-lowering action of sulfonylureas in vivo in NIDDM requires further study.

CHAPTER 4
BACKGROUND ON VANADIUM COMPOUNDS

4.1 VANADIUM

Vanadium is a common element that occurs in low concentration in the earth's crust. It is found in most living systems, and in high concentrations (0.15-1M) in specialized blood cells of sea squirts where it is thought to play a role in the oxygen carrying capacity, similar to that of the iron in the heme group of hemoglobin. Vanadium is widely distributed in tissues in mammals as an ultratrace element (344,345). The total body pool is estimated to be 100 µg on a daily intake of 10-60 µg. The serum concentration is 0.26-1.30 ng/ml (10 nM) according to Simonoff et al (346). Most tissues of higher animals contain intracellular vanadium at concentrations varying between 0.1-1 µM (347).

4.1.1. Physiological importance

The physiological importance of vanadium is not known. Nechay reported that vanadium is required (50-500 ng/g feed) for optimal growth of chickens and rats (344). Compounds of vanadium were given therapeutically for a variety of diverse disorders; as antiseptic, anti-tuberculous and anti-anemic agents, to boost resistance to infection and to improve appetite and general health (348). Its use was given up in 1930's.

The interest of biologists and biochemists increased when vanadate was discovered to be an inhibitor of Na⁺, K⁺ ATPase found in commercial preparations of ATP from equine and rabbit skeletal muscle (reviewed in (345,347,349). Subsequently, a new interest in vanadium compounds emerged when it was demonstrated in 1979 and 1980 that vanadate and vanadyl sulfate mimic the action of insulin on glucose metabolism in skeletal muscle and adipose tissue in vitro (350-352). In 1985, Heyliger first reported the successful treatment of streptozotocin-injected insulin-deficient rats with oral vanadate (353). Blood glucose concentrations were lower without a change in insulin concentrations substantiating the ability of vanadate to mimic insulin in vivo. Since then extensive studies exploring vanadium chemistry as well as the biological effects of vanadium on cells and tissues in vitro and in vivo have been performed. Additionally, aqueous solutions of peroxides of vanadium (peroxovanadium or pervanadate) (354) have also

been shown to have strong in vitro and in vivo insulin mimetic properties and novel vanadium and peroxovanadium compounds have been synthesized (355,356). More recently, studies carried out in human subjects have demonstrated the insulin-mimetic potential of these agents (357,358). Some of these data will be reviewed in the following sections where a summary of the chemistry, the in vivo and in vitro effects and toxicity of vanadium compounds is given.

4.2 CHEMISTRY OF VANADIUM AND PEROXOVANADIUM COMPOUNDS

4.2.1 Vanadate

Vanadium was discovered in 1801 by del Rio who called it erythronium. Later he retracted his claim because mistakenly he thought that it was a form of chromium. Swedish chemist Nils Sefstrom identified it in 1831 and named it after the Norse goddess of beauty Vanadis, because its solutions gave bright and different colors upon changes in pH and concentration. Vanadium has a complex chemistry due to multiple oxidation states (-1 to +5) and the tendency to polymerization at high concentrations (359). Vanadate is the name commonly used to describe the form of vanadium that exists in aqueous solution and will be used throughout this thesis. Vanadate can exist as a monomer (V1), dimer (V2), tetramer (V4) and pentamer (V5) which are in rapid equilibrium with each other in solution on a millisecond scale so that none of these species can be isolated and tested separately for aqueous biological studies. In the monomeric form (VO_4^{3-}) vanadate is structurally (tetrahedral or trigonal bipyramidal) and electronically related to phosphate (PO_4^{3-}) (see Figure 4.1). Different species (HVO_4^{2-} , H_2VO_4^- , H_3VO_4) are formed upon protonation of VO_4^{3-} which are presumed to be analogs of the corresponding phosphate derivative. The vanadate monomer oligomerizes to a dimer ($\text{V}_2\text{O}_7^{4-}$) which can exist in several protonated forms ($\text{HV}_2\text{O}_7^{3-}$, $\text{H}_2\text{V}_2\text{O}_7^{2-}$, $\text{H}_3\text{V}_2\text{O}_7^-$) depending on the pH. After formation of the dimer, vanadate tetramers may form ($\text{V}_4\text{O}_{12}^{4-}$) which are the major species in concentrated solutions. The x-ray structures of vanadate tetramer salts have been reported to be cyclical. The pentamer ($\text{V}_5\text{O}_{15}^{3-}$) is also presumed to be cyclic even though no structural information is available. Vanadate decamer (V10) forms between pH 2

Figure 4.1 Similarity of structure and charge among phosphate, vanadate and peroxovanadate.

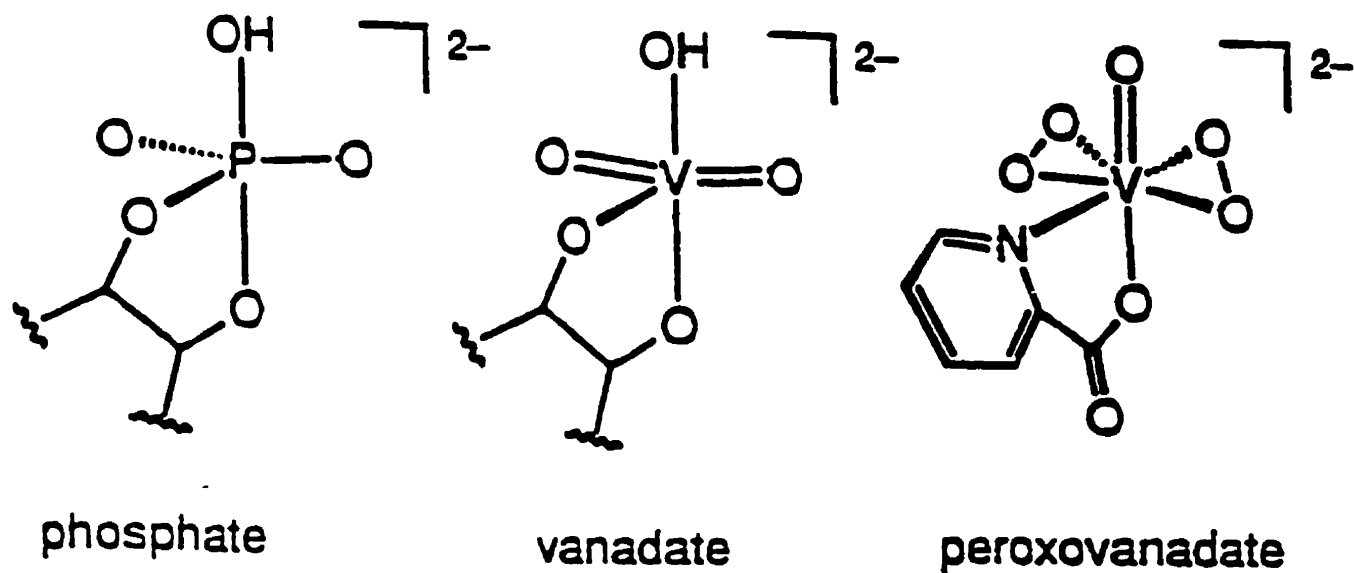

Source of Figure: A. Shaver et al. (Mol. Cell. Biochem. 153: 5-15, 1995).

and 6 and is thermodynamically unstable at neutral and basic pH. Vanadate reacts with reducing agents to form vanadyl ion (VO^{2+}), also discussed in literature as vanadyl (IV). This occurs in the presence of several compounds commonly found in the cell and /or in assay solutions such as L-ascorbic acid, glutathione (GSH), cysteine and possibly NADH (359,360). Each vanadate oligomer gives resolved resonances in the ^{51}V NMR spectrum and variable temperature NMR spectroscopy can be used to measure the rates of interconversion of the vanadate oligomers in aqueous solution (359,360). In contrast vanadyl complexes have an unpaired electron, are paramagnetic and thus not suitable for NMR studies. However electron spin resonance (ESR) can be used for their characterization (361,362).

Vanadate has been shown to interact strongly with organic buffers such as triethanolamine, tricine and bicine and therefore these buffers should be avoided in biological studies with vanadate. Also vanadate interacts with inorganic buffers. It forms a complex with phosphate and presumably also with carbonate and borate. Thus phosphate buffers are not recommended for biological studies of vanadate. Other assay components added to protect against heavy metal ions (EDTA, citrate), to maintain a reducing environment and prevent the oxidation of an enzyme (DTT), to prevent either protein dissociation or association with glass or plastic containers (glycerol, ethylene glycol, BSA) can interact with vanadate. Although these assay components (with the exception of EDTA) do not interact as strongly as the organic buffers tricine and triethanolamine, they should be maintained at sufficiently low concentrations so that even if complexes will form in an assay solution they will be negligible and not affect enzyme activity. Hepes is the best buffer for studying vanadate chemistry and the effects of vanadate on enzyme reactions. The choice of buffer, temperature, pH and ionic strength should be carefully controlled in biological studies.

In biological systems the +5 (vanadate or V) and the reduced +4 (vanadyl or IV) oxidation states are the predominant forms. The existence of two major oxidation states may complicate the interpretation of some biological actions. Electron spin resonance spectroscopy showed that vanadate intracellularly exists in the reduced vanadyl VO^{2+} (+4) form (347). Vanadyl is complexed with GSH in a 1:1 stoichiometry and its oxidation to vanadate which

could occur at a neutral intracellular pH is prevented. In other studies it was estimated that intracellularly most vanadyl (only 1% is free) is bound to ATP, ADP and phosphocreatine in muscle and is protected from oxidation to the +5 state (363). It is not clear which of the two species is responsible for insulin mimetic actions since both vanadate and vanadyl compounds are used in both *in vivo* and *in vitro* studies but recent studies (reviewed in (364)) suggest that vanadate may be the active species (see below).

Because inorganic vanadium is poorly absorbed from the gastrointestinal (GI) tract and GI disturbances have been reported with the different orally administered vanadium compounds, a number of organic vanadium compounds have been synthesized. One of the first and best studied is bis (maltolato) oxovanadium (IV) (355,365). This "organovanadium" compound demonstrates increased absorption and apparently, at least in rodents, decreased GI toxicity. The different vanadium compounds available today are shown in Table 4.1. Among these, sodium orthovanadate (Na_3VO_4), sodium metavanadate (NaVO_3) and vanadyl sulfate (VOSO_4) have been the most commonly used in research.

4.2.2 Pervanadate

In the course of study of insulin mimetic agents (discussed later) it was discovered that vanadate in combination with H_2O_2 had a synergistic effect to mimic insulin biological effects and to activate the insulin receptor kinase. Adding catalase an enzyme found in almost all cells, that catalyzes the breakdown of H_2O_2 prevented synergism between vanadate and H_2O_2 while delaying this addition for 15 min allowed full synergism suggesting that a reaction occurred which resulted in a new species. This was a peroxide of vanadate, named pervanadate (354). In 1893 A. Werner formulated the coordination theory for chemistry for which he received the Nobel prize in 1913. According to this theory every metal ion has one outer and one inner coordination sphere and species such as water, ammonia, chloride ion and peroxide ion can occupy either sphere. Occupation of the outer sphere does not substantially affect their properties but once they enter the inner sphere, these species form covalent bonds with the metal and are not easily lost. The inner sphere has a well defined geometry and crystalline materials are

Table 4.1 Available vanadium salts

Name	Chemical formula
Sodium orthovanadate	Na_3VO_4
Sodium metavanadate	NaVO_3
Ammonium metavanadate	NH_4VO_3
Vanadyl sulfate	VOSO_4
Bis(cysteine, amide N-octyl) oxovanadium (IV)	Naglivan
Bis (maltolato) oxovanadium (IV)	(BMOV)
Bis (maltolato)dioxovanadate (V)	(BMO2V)
Bis (kojato)oxovanadium (IV)	(BKOV)

formed. In the reaction of pervanadate formation, it was concluded that the peroxide ion (O_2^{2-}) enters the inner coordination sphere of the ion metal of vanadate and is not consumed by catalase. More recently different peroxovanadium compounds have been synthesized (356) all of which contain a central vanadium atom, an oxo group, one or two peroxo ligands and an ancillary ligand. From these the most potent PTP inhibitors and insulin mimetics (356) are the bisperoxo-phenanthroline (bvp (phen)) with the chemical formula $K[VO(O_2)_2 \text{ phen}] \cdot 3H_2O$ and bisperoxo-picolinic acid (bvp(pic)) with the chemical formula $K_2[VO(O_2)_2 \text{ pic}] \cdot H_2O$. Peroxovanadium compounds also resemble the phosphate structure but the addition of peroxo group(s) sequentially increases their potency as protein tyrosine phosphatase inhibitors (see below) presumably by increasing their abilities to oxidize irreversibly the bound thiols (361).

Vanadate, and peroxovanadate or pervanadate in aqueous solution were used in the studies presented in this thesis and their structure is shown in Figure 4.1 together with the structure of phosphate. It should be noted that the observed stability of vanadium compounds in stock solutions does not imply stability after administration and uptake by cells. The stability under the latter conditions should be examined. Also, it has been shown that the reactivity of vanadium compounds with cell components will affect the compounds' insulin-mimetic properties (359). Therefore a focus exists to explore compounds with increased stability and a modified reactivity pattern in order to facilitate the development of vanadium compounds for therapeutic use as oral insulin substitutes.

4.3 TRANSPORT INTO CELLS

The availability of radioactive vanadium compounds is lacking and therefore studies on cellular uptake are very limited. It is thought that the cellular uptake of vanadate probably takes place by an anion transporter with high affinity for phosphate (366-368).

4.4 ENZYME INTERACTIONS

Vanadate has been shown to alter the activity of many enzymes in vitro. It inhibits the "P" type phosphorylated membrane ATPases such as Na⁺, K⁺ ATPase, Ca⁺⁺ ATPase, Mg⁺⁺ ATPase, (366,369,370). This has been demonstrated directly in vitro and involves the formation of a relative stable vanado-enzyme transition state analog. Subsequently vanadate was found to inhibit a number of phosphatases including acid and alkaline phosphatases (371), as well as protein tyrosine phosphatases (PTPs) (372-375). The latter observation, made during the time when the importance of tyrosine phosphorylation in cellular function was recognized (376) led to great interest in using vanadate both as a pharmacological probe as well as a standard ingredient of cell and tissue isolation buffers to preserve endogenous levels of protein tyrosine phosphorylation. Furthermore the cloning and sequencing of the insulin receptor and its recognition as a tyrosine protein kinase (12) strongly supported the concept that PTP inhibition was relevant to most if not all of the insulin-mimetic actions of vanadate. It should be noted that vanadate does not inhibit serine/threonine phosphatases. Other enzymes which are inhibited by vanadate include RNase, dynein ATPase, phosphoglucomutase and glucose-6-phosphatase (G6Pase) (377,378), (reviewed in (379)). It has been suggested that inhibition of G6Pase may contribute to the glucose lowering action of vanadate in vivo ((378), see below)

In contrast to the inhibition of most enzymes with which it interacts vanadate has been reported to activate adenylate cyclase. This was first demonstrated in rat adipocyte membranes (380) and may be an indirect effect mediated by an interaction of GDP-V with GTP binding proteins to activate the enzyme or mediated by oligomers since high (mM) concentrations are required (381). Although this action in adipocytes would be expected to stimulate lipolysis, vanadate treatment of intact adipocytes results in an antilipolytic action (347,382). A vanadyl sulfate-GSH solution was shown to inhibit purified cAMP dependent protein kinase (383). Whether or not this latter action is involved in the insulin-like antilipolytic effect of vanadate is not clear. However this example illustrates that caution is required when extrapolating from in vitro to in vivo actions.

4.5 METABOLIC ACTIONS

Almost all of insulin's effects on glucose uptake and metabolism have been stimulated by vanadate in cultured cells and isolated tissues as is shown in Table 4.2 (reviewed in (347,363)). However, the effects of vanadate on fat and protein metabolism have not been evaluated in as much detail. In rat adipocytes vanadate effectively inhibits lipolysis and stimulates lipogenesis (347,382), and also mimics insulin in isolated hepatocytes to inhibit VLDL release (384).

Pervanadate also mimics many of the actions of insulin in vitro. In almost all the studies reported pervanadate has been found to be 100-1000 times more potent than vanadate as an insulin mimicker and in some cases, where no effect of vanadate can be detected, the action of pervanadate is clear and significant (385).

4.5.1 Actions opposite to insulin

There are reports suggesting that vanadate has effects opposite to insulin or that it fails to mimic a certain action of insulin. Bosch et al, found that vanadate inactivated glycogen synthase and activated glycogen phosphorylase in liver cells isolated from both fasted and fed rats. This effect was similar to glucagon action in liver cells (386) but was found at relatively high concentrations. In rat epitrochlearis muscle, although vanadate stimulated glucose uptake, glycogen synthesis and glycolysis, unlike insulin it did not stimulate protein synthesis or inhibit protein degradation (387). Thus the anabolic effect of insulin on protein metabolism in skeletal muscle is not mimicked by vanadate in vitro. Stimulation of protein synthesis has been reported in adipocytes by the more potent peroxovanadium (382) but in contrast to glucose metabolic effects this was not as effective as insulin. The reasons for this discrepancy is not clear but one might speculate that this signal transduction pathway involves a PTP. Therefore the net action on a given signalling pathway will dependent on the relative amounts and activities of the PTPs

Table 4. 2 Insulin-like effects of vanadium compounds in insulin target tissues.

I; increase, D; decrease, ND; not determined, NE; no effect observed. IR; insulin receptor, IRTK; insulin receptor tyrosine kinase, PTP; protein tyrosine phosphatase, *; hepatoma cells. Some of the differences between vanadate and pervanadate have been outlined in Bevan et al (Mol. Cell Biochem. 153:49-58, 1995).

Action	Skeletal muscle	Adipocytes	Hepatocytes
glucose transport	I	I	I
glucose oxidation	I	I	ND
glycolysis	I	I	ND
glycogen synthesis	I	I	I
glycogen synthase	I	I	I
lipogenesis	ND	I	I
lipolysis	ND	D	ND
amino acid transport	I/D	ND	D*
protein synthesis	NE	I	ND
IR phosphorylation	ND	I	I
IRTK activity	NE	I	I
PTP activity	D	D	D
GLUT translocation	ND	I	ND
IGF-II binding	ND	I	ND
Transferin binding	ND	I	ND
IR downregulation	ND	I	ND
Insulin sensitivity	ND	I	ND

involved in that pathway and their relative sensitivities to inhibition by vanadate. Variable results have also been observed in regard to vanadate's effect on amino acid transport which may be explained by a similar phenomenon. While some have found stimulation of amino acid uptake in muscle (388) vanadate inhibits amino acid uptake in intestinal cells (389) and in cultured L6 myotubes (see Chapter 5 of this thesis).

4.6 NONMETABOLIC ACTIONS OF VANADATE

The role of tyrosine phosphorylation in mitogenic signalling is well documented and one would predict that vanadate, by inhibiting PTPs would increase the level of tyrosine phosphorylation in cells and therefore may act as a growth stimulator. Indeed many studies of cultured cells show a stimulation of cell growth in the presence of vanadate alone or an enhancement of mitogenesis when it is combined with growth factors (390-392) and reviewed in (393).

However, at the same time a number of reports indicate that vanadate may inhibit cell proliferation and vanadium compounds have been proposed as potential chemotherapeutic agents to inhibit tumor cell growth (394,395) and reviewed in (396). Recently, a number of PTPs such as SHP2/SYP and the dual specificity phosphatase cdc 25 have been described which are involved in the propagation of cell proliferation (397-399). This combined with the relative lack of specificity of vanadate as a PTP inhibitor provide a potential mechanism. Thus vanadate may inhibit cell proliferation by inhibiting the phosphatases that are involved in cell cycle progression and mitogenesis. Both vanadate (400) and pervanadate (401) interrupted the cell cycle at the G2/M phase in which the activation of the cyclin dependent kinase (CDK1/cdc2)-cyclin B complex is dependent on cdc2 dephosphorylation by cdc25. Thus the net effect of vanadate on cell growth in vivo will depend on the stage of the cell cycle, the relative concentrations of vanadate and specific PTPs and, in tumor cells, particular mutations which may render a cell more or less responsive.

Other actions of vanadium compounds may also occur subsequent to PTP inhibition. Examples include activation of NADH oxidase in neutrophils (402), activation of the JAK-STAT

(Janus kinase-signal transducers and activators of transcription) pathway (403), a tyrosine kinase-dependent signalling system utilized by various hormones and cytokines (404) and alterations of receptor protein trafficking (405).

4.7 IN VIVO EFFECTS OF VANADATE

The insulin-mimetic properties of vanadium compounds in vitro prompted investigators to examine the possible in vivo insulin-like effects. Vanadium compounds were therefore tested in animal models of diabetes mellitus. The most widely used models of type I diabetes in animals are:

- 1) Alloxan and streptozotocin (STZ) induced diabetes: Alloxan or STZ injection of animals induces a model of type I diabetes mellitus. The animals are hyperglycemic and hypoinsulinemic. The severity of the diabetic state depends on the dose of the drug used and the degree of destruction of the pancreatic β -cells.
- 2) Pancreatectomy: Partial pancreatectomy by removal of approximately 90 % of the pancreas of animals produces a hypoinsulinemic model of diabetes mellitus.
- 3) Strains of animals that are genetically prone to type I diabetes. There are commercially available strains of rats such as the BB Wistar rats that are genetically prone to the development of insulin dependent type I diabetes. BB rats are diabetic due to an autoimmune destruction of the B cells.

Several animal models of type II diabetes and /or insulin resistance are also available which are characterized by mild to marked hyperglycemia, hyperinsulinemia, obesity and glucose intolerance. These models include:

- 1) ob/ob mice
- 2) db/db mice
- 3) fa/fa Zucker rats
- 4) High sucrose fed rats
- 5) Spontaneously hypertensive rats (SHR)

6) Fructose-induced hypertensive rats

Vanadium compounds have been administered to all of the above mentioned models of diabetes and their abilities to lower blood glucose and/or improve various characteristics of the insulin resistant state such as hyperlipidemia and hypertension were examined (Table 4.3). Heyliger et al (353) were the first to demonstrate that vanadate has insulin-mimetic actions in vivo. Control and STZ-induced diabetic rats were given sodium orthovanadate (Na_3VO_4) at 0.8 mg/ml in 0.9 % NaCl in the drinking water. In diabetic vanadate-treated rats plasma glucose levels were restored to normal without an increase in circulating plasma insulin levels. Furthermore, in almost all studies of the various diabetic models elevated glucose concentrations were decreased, hypertriglyceridemia was improved and in the spontaneously hypertensive rat (SHR) the development of hypertension was mitigated (reviewed in (347,406,407)). Although there has been some variability in success rates in the hands of different investigators, the effectiveness of these compounds, at least in rodents is established. Many studies also demonstrated improvement or normalization of physiological and biochemical components of insulin action. Hepatic glucose output was decreased and peripheral glucose uptake enhanced. Enzyme activities such as glucose-6-phosphatase, fructose-2,6 bisphosphatase and pyruvate kinase as well as gene expression were normalized (372).

In some cases of streptozotocin-induced diabetes withdrawal of vanadate did not result in a return of the diabetic state suggesting that insulin secretory capacity was preserved (408). These data combined with the observation that vanadate administration lowered insulin requirements but could not completely replace insulin in the BB (biobreeding) Wistar diabetic rat (406) suggest that in vivo some insulin is required for vanadate effectiveness.

Recently two short term studies in human subjects with diabetes mellitus have been completed (357,358). In 5 patients with IDDM (Type I diabetes) there was an average 14% reduction in insulin requirements after 2 weeks of therapy with Na metavanadate (125 mg/d) (357). Although changes in peripheral glucose uptake and hepatic glucose output were not observed in IDDM, in NIDDM (Type II diabetes) there was an enhancement of peripheral insulin sensitivity manifested as an increase in nonoxidative glucose disposal into muscle. In the second

Table 4. 3 Rodent models of diabetes and/or insulin resistance treated with vanadium compounds.

In all these models vanadium compounds were found to decrease hyperglycemia and bring the blood glucose levels to normal or near normal levels.

Model of diabetes	vanadium compound	References
Streptozotocin- injected	Sodium orthovanadate (Na ₃ VO ₄)	Heyliger et al, (353) Brichard et al, (409) Gil et al, (372)
	Sodium metavanadate (NaVO ₃)	Meyerovitch, (410) Bendayan et al, (411)
	Vanadyl Sulfate (VOSO ₄)	Domingo et al, (412) Cam et al, (413)
	BMOV	Yuen et al, (414)
	Naglivan	Yuen et al, (414)
Pancreatectomized	Vanadyl Sulfate (VOSO ₄)	Rossetti et al, (415) Rossetti et al, (416)
	Vanadyl Sulfate	Battell et al, (417)
BB wistar rats	Pervanadate	Yale et al,(418)
ob/ob mice	Na ₃ VO ₄	Meyerovitch, (419) Brichard et al, (420)
	Na ₃ VO ₄	Meyerovitch, (419)
db/db mice	Na ₃ VO ₄	Meyerovitch, (419)
fa/fa zucker rat	Na ₃ VO ₄	Brichard et al, (421)

study 3 weeks of treatment of 6 NIDDM subjects with vanadyl sulfate (100 mg/d) resulted in improvement in metabolic control, no change in fasting or stimulated insulin and an increase in insulin-stimulated peripheral glucose uptake, particularly enhanced glycogen synthesis, as well as inhibition of hepatic glucose production (358). These human studies are consistent with those in rodents (419,422,423) and *in vitro* (424,425) which demonstrate not only direct insulin-mimetic actions but also enhancement of insulin sensitivity. In contrast to NIDDM, 3 weeks of vanadyl sulfate administration to obese nondiabetic subjects did not alter insulin sensitivity (426).

Although the data obtained from the studies performed in humans and animals are consistent the effects observed in humans are smaller than those seen in rodents. This may reflect differences in doses, blood levels and /or the time course of action of vanadium compounds. The dose of oral vanadate in rodents which has been found to improve blood glucose is about 100 mg/kg/day while in humans the doses used were about 1.5 mg/kg/day. The serum concentrations of vanadium achieved in rodents was between 10 to 20 μ M, while the level in human studies was between 1 and 5 μ M (357,358). In STZ-diabetic and BB rats vanadate added to the drinking water lowered blood glucose levels within 3-4 days (353,410,427) while in ob/ob and db/db mice the same effect required 10-20 days (419,420) demonstrating a different time course of action in the different models of diabetes. In humans the treatment period in these initial studies was only 2-3 weeks and therefore studies of longer duration are needed in order to fully evaluate the potential of vanadium compounds.

It was reported that delaying treatment of STZ-induced diabetic rats with vanadyl sulfate for 3, 10 or 17 days after STZ injection did not alter the vanadyl sulfate glucose lowering properties (413) suggesting that the effectiveness of vanadium treatment is the same regardless of the timing of therapy in relationship to onset of diabetes. Also removal of vanadyl treatment for 13 weeks after an initial 3 week period of treatment of STZ-diabetic rats showed that plasma glucose remained normalized (428). The maintenance of improved metabolic control after withdrawal of vanadium therapy was suggested by the human studies as well since lower blood glucose concentrations were observed two weeks after cessation of therapy (357,358). The

mechanism of action for the sustained euglycemia observed after withdrawal of vanadium therapy is not known.

4.8 MECHANISM OF INSULIN MIMETIC ACTION OF VANADATE

4.8.1 Protein Tyrosine Phosphatase (PTP) inhibition.

There are two major classes of PTPs. The large transmembrane receptor like molecules and the cytoplasmic PTPs (429). There are over 20 PTP genes that have been cloned but the role of many of these enzymes in normal cell physiology has yet to be defined (430). Vanadate is a potent inhibitor of cellular PTPs and especially cytosolic ones (374,375,430,431)

As discussed in the background on insulin action, the regulation of tyrosine phosphorylation of the insulin receptor itself and its substrates and the balance between tyrosine phosphorylation and dephosphorylation are potential key mechanisms for altering insulin action. Vanadate via its inhibitory action on PTPs can alter the balance of tyrosine phosphorylation and dephosphorylation in the cell and therefore modulate or mimic the action of insulin. Most data support the inhibition of PTPs and resultant indirect stimulation of tyrosine phosphorylation as the mechanism by which vanadium compounds promote their insulin-like effects (Figure 4.2).

In *in vitro* studies where isolated cell systems are used the inhibitory effect of vanadium compounds on PTPs is easily demonstrated although somewhat higher concentrations are required than those achieved *in vivo* during treatment of diabetic animals or humans. Swarup et al were the first to show that sodium orthovanadate at 1-10 μM inhibited strongly and specifically tyrosine phosphatases present in A 431 cells without affecting serine/threonine phosphatases (374,375). Pervanadate is a more potent inhibitor of PTP activity and in rat adipocytes (382) and hepatocytes (432) it was demonstrated to be 100 -1000 times more effective in mimicking insulin compared to vanadate.

The ability of vanadate to inhibit PTPs allows the use of this agent to probe the role of PTP activity in the physiology of insulin action and resistance. The net hormonal signal will depend on the balance between receptor tyrosine kinase (RTK) and PTP activities. In the case of

Figure 4.2 Sites of potential protein tyrosine phosphatase (PTP) inhibition by vanadium compounds.

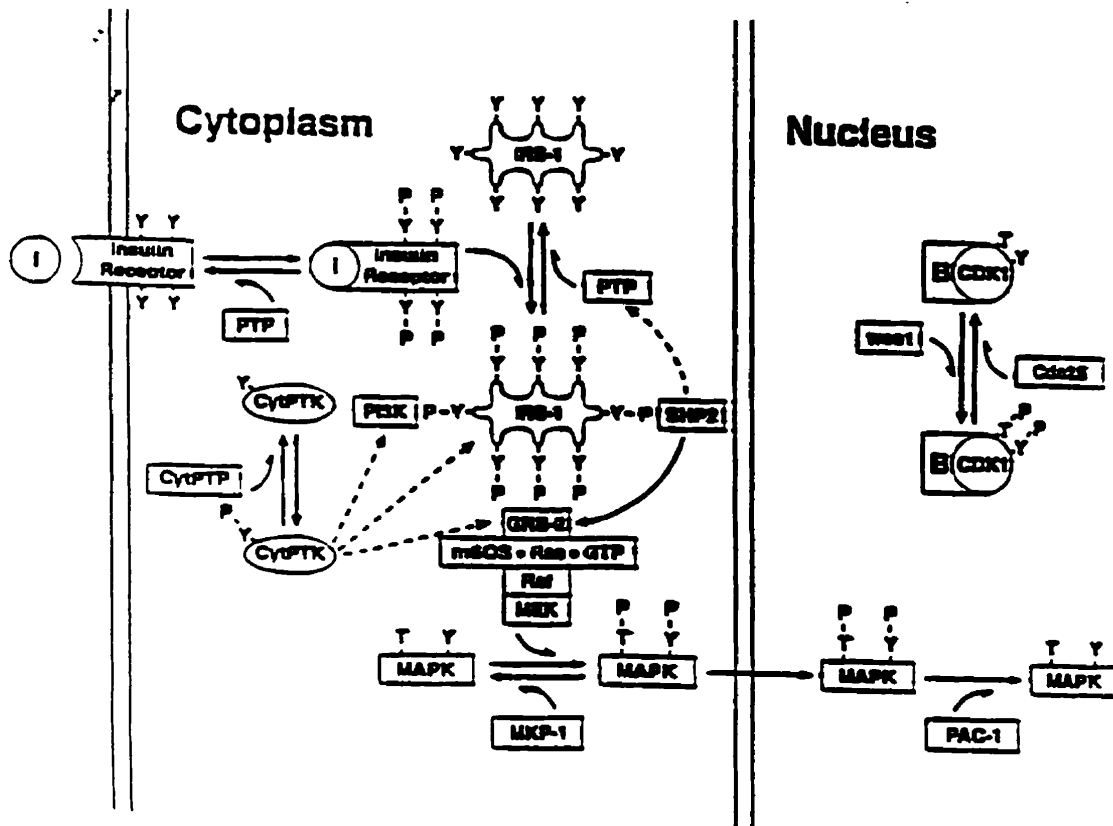

All tyrosine phosphorylation steps in the insulin signalling pathway are potentially also regulated by tyrosine phosphatases. The specific PTPs responsible for dephosphorylation of the IR and IRS-1 *in vivo* are not defined. SHP2 may contribute to IRS-1 dephosphorylation but has been shown to participate in the mitogenic response to insulin. MAPK activation by vanadate may not require ras activation but occur indirectly via inhibition of cytosolic (MKP-1) and/or nuclear (PAC-1) dual specificity phosphatases. Cytosolic tyr kinases are also activated by vanadate presumably by inhibition of cytosolic (cyt) PTPs. These cyt PTKs may signal similar and/or additional SH2 domain containing protein pathways. In the nucleus inhibition of other dual specificity phosphatases such as cdc25 may result in disruption of the cell cycle. CDK, cyclin dependent kinase. The Figure is a modification of the one originating in : Fantus et al 1995 (Mol. Cell. Biochem. 153: 103-11, 1995).

insulin there are "spare" receptors such that maximum response is achieved at subsaturating concentrations of hormone (23). The augmentation of RTK activity by vanadate in such a circumstance has been demonstrated to lead to an apparent increase in sensitivity to insulin as well as to a prolongation of insulin action (433). Thus, vanadate may render lower concentrations of endogenous or exogenous insulin more effective.

4.8.2 Effect on insulin receptor and insulin receptor kinase

Early studies focused on the possibility that vanadate stimulates phosphorylation of the insulin receptor either directly or via its inhibitory effect on phosphotyrosine phosphatase activity. In rat adipocytes Tamura et al showed that vanadate directly stimulates highly purified insulin receptor tyrosine phosphorylation in the absence of insulin (434). However these findings were not confirmed by other studies. Increased insulin receptor tyrosine kinase activity has been reported by others in isolated rat adipocytes (424,433) and in liver isolated from vanadate treated diabetic animals (435). Also vanadate treatment of 90% pancreatectomized rats increased basal activity (no change in insulin-stimulated activity) of the insulin receptor tyrosine kinase an effect not observed simply by correcting hyperglycemia with phlorizin (436). These results could be accounted by indirect activation of the IR by vanadate inhibition of PTPs. Furthermore in rat adipocytes vanadate was found to increase insulin binding by increasing the affinity of the receptor for insulin. This was also associated with an increase in insulin sensitivity (424).

In contrast to these findings the action of vanadate to activate the insulin receptor tyrosine kinase has not been observed in other studies (437-440) and when tissues of vanadate-treated diabetic animals were examined no increase in either receptor or substrate phosphorylation was observed (437). Therefore IR tyrosine phosphorylation is not consistently observed and it has been reported that inhibition of the IR kinase does not abolish several effects of vanadate on glucose metabolism (441) suggesting that vanadate may act at other sites. While this is the case for vanadate, there is some evidence that pervanadate and pV compounds do act predominantly via the IR (356,442). This may relate to differences in specificity and /or potency as PTP

inhibitors as well as more rapid entry of pV into tissues. Therefore, in contrast to vanadate which had minimal effect, pervanadate produced an activation of the insulin receptor tyrosine kinase as measured by ^{32}P incorporation into the insulin receptor β -subunit and a synthetic substrate (382,443). Furthermore in contrast to the effect seen in cells expressing normal insulin receptors in cells (HTC-M1030) overexpressing kinase deficient insulin receptors pervanadate compounds were unable to increase tyrosine phosphorylation of IRS-1 and other proteins and the association of IRS-1 with p85 of PI-3 kinase was not enhanced (444). Pervanadate complexes do not activate the insulin receptor kinase following partial purification of the receptor on lectin columns suggesting that their capacity to activate insulin receptor kinase in intact cells is due to inhibition of a PTP (356). It has been suggested that pervanadate inhibits PTPs that regulate the phosphorylation levels of tyrosines 1162 and 1163 of the insulin receptor kinase which then leads to increased phosphorylation levels of various intracellular proteins (445).

4.8.3 Role of cytosolic tyrosine kinase

Vanadate may promote some insulin-like effects via activation of a 54 kDa cytosolic tyrosine kinase in rat adipocytes (446). A number of such src-like tyrosine kinases exist and it is plausible that several similar downstream events are triggered by both the IR and such a tyrosine kinase or that such a kinase is a normal component of the insulin action pathway. It should be noted that recently the src-like tyrosine kinase Fyn binds to IRS-1 and may contribute to insulin signalling (447). Some bioeffects such as lipogenesis appeared to be mediated via a cytosolic tyrosine kinase pathway while others, such as glucose transport were not (446). Furthermore vanadate, although a nonspecific PTP inhibitor, was found to be 10-fold more efficacious in inhibiting cytosolic PTP activity (20 μM) as compared to that in the particulate fraction (200 μM) (357). Such an inhibition of cytosolic PTP may result in the activation of a cytosolic protein tyrosine kinase. Another group of cytosolic tyrosine kinases, the JAKs, have recently been found to phosphorylate the major IR substrates, IRS-1 and 2 (93) and may also function to transmit vanadate actions. Thus, there are likely differences in the signalling pathways utilized

for the various insulin-like bioeffects and possibly different but overlapping mechanisms for the various vanadium compounds, particularly vanadate versus peroxovanadium.

4.8.4 Role of insulin signalling molecules

4.8.4.1 Role of PI 3-kinase

Apart from the indirect activation of tyrosine kinases, vanadium compounds may stimulate signals downstream of the insulin receptor such as PI 3-kinase and MAPK. Injection of vanadate together with hydrogen peroxide (H_2O_2) (pV) to anesthetized rats resulted in increased phosphorylation of IRS-1 and its association with p85, (the regulatory subunit of PI-3 kinase) in liver similar to that seen with insulin. However the physiological importance of this event was not examined (445). Although PI 3-kinase activation is required for insulin-stimulated glucose transport (discussed in Chapter 1), it is demonstrated in this thesis (see chapter 6) that vanadate and pV can stimulate glucose transport in the presence of the PI 3-kinase inhibitor wortmannin. These data suggest that PI 3-kinase is not required for the increase in glucose transport seen with vanadate and pervanadate.

4.8.4.2 Role of MAPK

Vanadate has been shown to activate MAPK in studies in CHO cells overexpressing the human insulin receptor by a mechanism independent of the insulin receptor tyrosine kinase (448). Activation of MAPK may occur indirectly by inhibition of the vanadate sensitive dual specific MAPK phosphatase (MKP-1) (449). Vanadium salts also activated the 90 kDa ribosomal S6 kinase (p90^{rsk}) and 70 kDa ribosomal S6 kinase (p70^{s6k}) (450). Chronic treatment of STZ-diabetic rats with vanadate resulted in normoglycemia and restoration of MAPK and S6 kinase activity (451). NIDDM and IDDM patients were found to have a decreased insulin-stimulated MAPK and S6 kinase activity. Treatment with sodium metavanadate for 2 weeks increased the basal activity of both MAPK and S6 kinase to levels similar to the insulin-stimulated levels in control subjects. Insulin did not further stimulate these activities (357).

These data suggest that vanadate enhances the activity of these enzymes possibly by inhibition of a MAPK-specific phosphatase.

4.8.4.3 Vanadate effect on glucose transporters.

Vanadium compounds may modulate glucose transporters, the downstream effectors of glucose transport in the insulin signalling pathway. In 3T3-L1 adipocytes it has been reported that acute stimulation with vanadate results in increased glucose transport into the cells which was associated with a translocation of GLUT 4 glucose transporters from an intracellular storage pool to the plasma membrane (452). This findings suggested that vanadate, similar to insulin, increases peripheral glucose uptake by modulating the glucose transporter proteins. Chronic exposure to vanadate increased GLUT 1 protein and mRNA levels in rat fibroblasts (453). However, the *in vivo* effect of vanadate treatment on glucose transporters is not clear. Vanadate treatment of STZ-induced diabetic rats resulted in an increase in GLUT4 protein levels (187% of control) and mRNA levels (187%) in skeletal muscle tissue (454). In contrast chronic administration of vanadate in genetically obese fa/fa insulin resistant Zucker rats resulted in improved peripheral insulin sensitivity (as seen by an increase in insulin stimulated glucose uptake determined under hyperinsulinemic euglycemic clamp) without any changes in GLUT 4 mRNA or protein levels in all heart, skeletal muscle and adipose tissue (455).

It is most likely that acute vanadate treatment of cells causes translocation of GLUTs. Vanadate also acutely increased the binding of IGF-II (443,456), transferrin and LDL (405) in cells by causing translocation of the corresponding receptors all of which are examples of translocation processes similar to that of glucose transporters.

4.8.5. Pancreatic effects of vanadate

The possibility that vanadate reduces blood glucose levels by affecting plasma insulin levels was examined in various studies. In both STZ-diabetic rats and db/db mice oral administration of vanadate improved blood glucose levels without increasing serum insulin

levels (353,410). As well the insulin levels in control animals treated with vanadate were decreased without any change in plasma glucose values (353). Similar findings have been reported by others supporting the conclusion that the primary site of vanadate action is on insulin target tissues. Additionally from the *in vivo* studies in humans it was observed that sodium metavanadate treatment of NIDDM patients for 2 weeks did not change the basal, first phase or second phase insulin and C-peptide secretion while IDDM patients showed a small but significant decrease in mean daily insulin requirements (357). However some studies suggest that vanadate also has some effects on the pancreas. Pederson et al found that early treatment of STZ-diabetic rats with vanadate preserved islet insulin content and insulin secretion although circulating insulin levels were still subnormal (408). Long term correction of diabetes has been observed after withdrawal of vanadate treatment raising the possibility that endogenous insulin secretory capacity is preserved and/or restored (457,458). It is not clear however whether this is a direct effect on the pancreas or an indirect protective effect due to correction of hyperglycemia.

4.8.6 Other contributions to glucose-lowering action

Two other effects of vanadate may contribute to its glucose lowering action. First, it was noted in early studies performed in rodents that oral administration of vanadate decreased food and fluid intake (353). Indeed body weight gain was significantly reduced in the control animals receiving vanadate. The same decreased weight gain was observed in control animals treated with vanadyl sulfate and BMOV. These observations and one study by Malabu et al suggested that the effects of vanadate to reduce hyperglycemia might be due entirely to its inhibition of feeding (459). Furthermore intracerebroventricular administration of vanadate decreased food intake in rats (437) and insulin crossing the blood-brain barrier has been demonstrated to contribute to satiety (460). It is unknown whether any form of oral vanadate may access the CNS to exert insulin-like effects. However in other studies in partially pancreatectomized diabetic rats (415) and in obese hyperinsulinemic *fa/fa* rats (421) in which untreated diabetic rats were pair-fed to match the vanadate treated animals there was a similar improvement in blood glucose levels

attributable to the vanadate therapy suggesting that the insulin-mimetic actions could not be attributed to the reduction in food intake. Thus the contribution of decreased food intake to the improvement of hyperglycemia by vanadate as documented to happen in various models of diabetes remains controversial (459). It should be mentioned that in short-term studies in humans no significant changes in food intake were found.

Another effect of oral vanadate treatment of control and STZ-diabetic rats was a reduction in Na⁺-dependent glucose transport in the small intestine due to downregulation of the Na⁺-dependent glucose transporter raising the possibility that some of the effects of the vanadium compounds might be related to slower glucose absorption (461). However it is unlikely that at therapeutic doses, this effect plays a major role. In addition, administration of vanadium compounds by a route bypassing the intestine such as intraperitoneal or intravenous, results in a reduction in plasma glucose levels (418,462) establishing that these agents do have insulin-mimetic effects *in vivo* independent from the possible effects on food intake or absorption. It may be noted that consistent with its greater insulin-mimetic potency pV is effective by intravenous administration while this is not the case for vanadate which appear also to have a slower onset of action (418).

4.9 POTENTIAL SIDE EFFECTS AND TOXICITY OF VANADIUM COMPOUNDS

In early studies in rodents decreased fluid and food intake and diarrhea were the major toxic effects and led to increased morbidity and mortality (463). Introduction of the agents at low doses with a gradual increase to maintenance levels prevents these effects. In humans both vanadyl sulfate and Na metavanadate resulted in some nausea which responded to a decrease in dose. Studies in rodents suggest that modification of the vanadium species with organic ligands may decrease the GI side effects and enhance absorption resulting in an apparent increased potency (414). Peroxovanadium compounds are more potent PTP inhibitors but are degraded in the gastric acidic environment (464).

Long term administration of vanadate and vanadyl sulfate to rats has not been associated in most studies with any major toxicity (349). At higher doses there have been effects in male

mice to reduce sperm count (463). Other studies reported decreased hemoglobin levels in rats and Cohen et al (358) noted a very small drop in hematocrit in treated human subjects which was maintained for two weeks after discontinuation of treatment. One other important adverse effect has been developmental and embryotoxicity in rats and mice (463,465). This has important clinical implications since one might expect fetal tissues to be more sensitive and these agents would not likely be considered for use during pregnancy or lactation.

A most important concern in the long term use of any drug is its carcinogenic potential. While there is no evidence in long term studies in rats or in humans exposed to vanadium of an increased incidence of neoplasms, the known role of tyrosine kinases in mitogenesis and the many *in vitro* studies documenting the ability of vanadate to stimulate growth or potentiate the effects of growth factors indicates that this issue must be carefully evaluated. It is not known whether under certain circumstances oral vanadium compounds may promote or enhance tumor growth.

An additional measure of potential long term toxicity is tissue accumulation. In treated rats vanadium accumulated mostly in kidney, spleen, testes, liver and bone (463,466). Presumably some equilibrium is reached in most soft tissues which do not store vanadium, however its similarity to phosphate would result in a potential continuous accumulation in bone. Whether this is of clinical relevance remains to be determined.

4.10 SUMMARY

Vanadium is a trace element and its compounds are an interesting group of chemicals for which a function in mammals is still unknown. These compounds have been shown to exert a wide variety of insulin like effects in isolated cell systems and have the ability to lower blood glucose levels in several experimental models of diabetes mellitus as well as in humans with diabetes. Although the exact mechanism involved in the hypoglycemic effects is not clear, evidence suggest that they predominantly act in peripheral tissues to increase glucose uptake. The ability of vanadium compounds to inhibit protein tyrosine phosphatase activity (Figure 4.2) appears to be the most relevant for their hypoglycemic action. The pathway by which such an

action is mediated is not defined and is examined in chapter 6 where it is shown that the mediator of the insulin-induced increase in glucose transport, PI 3-kinase is not involved. An increased understanding of the molecular mechanisms by which vanadium compounds exert their actions is required since the possibility exists that they may be used as therapeutic agents to treat diabetes.

CHAPTER 5

THE INSULIN-MIMETIC AGENTS VANADATE AND PERVANADATE STIMULATE GLUCOSE BUT INHIBIT AMINO ACID UPTAKE IN MUSCLE CELLS.

5.1 ABSTRACT

The protein tyrosine phosphatase (PTP) inhibitors vanadate and pervanadate (pV) exert insulin-like biological effects. To study their actions in muscle, cultured differentiated rat L6 skeletal muscle cells were exposed to these agents and/or insulin and both 2-Deoxy-D-[³H]-glucose (2DG) and ¹⁴C-methylaminoisobutyric acid (MeAIB) uptake were measured. Vanadate and pV stimulated 2-DG uptake in a dose and time-dependent manner to a maximum after 90 min of $171 \pm 10\%$ and $167 \pm 6\%$ at 10 mM and 0.5 mM, respectively. Maximum insulin (10^{-7} M) stimulation was $167 \pm 11\%$ of control and there was no further increase by combining insulin with vanadate or pV. While 10^{-7} M insulin stimulated MeAIB uptake to $143 \pm 5\%$, 10 mM vanadate and 0.5 mM pV inhibited basal MeAIB uptake by $27 \pm 3\%$ and $69 \pm 7\%$, respectively. Insulin-stimulated MeAIB uptake was also inhibited in a dose-dependent manner and completely abolished by 5 mM Van or 0.1 mM pV. Furthermore vanadate completely blocked insulin-stimulated MeAIB uptake in rat hepatoma cells. Kinetic analysis revealed that the inhibitory effect on basal MeAIB uptake was associated with an increase in K_m and a small decrease in V_{max} while the insulin-stimulated increase in V_{max} was completely inhibited.

Ouabain, an inhibitor of Na^+/K^+ ATPase, did not inhibit MeAIB uptake and the inhibition by vanadate or pV was not blocked by cycloheximide. Twelve hours of amino acid deprivation of L6 cells resulted in stimulation of MeAIB uptake to $565 \pm 42\%$ of control in the absence but only to $209 \pm 25\%$ in the presence of 0.5 mM vanadate. In summary, vanadate and pV mimic insulin to stimulate glucose uptake in L6 cells but inhibit system A amino acid uptake. The relative inhibitory concentrations of vanadate and pV suggest that the mechanism may involve PTP inhibition.

5.2 INTRODUCTION

Skeletal muscle is a major target of insulin action and is the major site of postprandial glucose disposal (467,468). Insulin increases glucose uptake in muscle by inducing the translocation of glucose transporters from an intracellular compartment to the cell surface (127,139). Apart from its effects on glucose transport insulin also rapidly increases the transport of amino acids into skeletal muscle by the system A transporter (469). The system A carrier is membrane bound and transports short polar, straight-chain amino acids such as alanine and proline as well as the non-metabolizable analog 2-methyl-aminoisobutyric acid (MeAIB) (195). System A activity is pH sensitive, depends on the Na^+ electrochemical gradient and is also regulated by amino acid availability and exercise (470). In contrast to the recent advances in our knowledge of the mechanism involved in the stimulation of glucose transport by insulin (340) the mechanism of insulin stimulation of amino acid transport is very limited due in part to lack of information on the system A transporter at the protein and mRNA level.

The L6 myotubes represent a well-characterized cell culture model of skeletal muscle that allows the study of hormonal and metabolic regulation of the glucose and amino acid transport systems as it is discussed in 1.5. In myotubes insulin-stimulated glucose uptake is associated with a recruitment of glucose transporter proteins from an intracellular pool and their translocation to the plasma membrane (339). Insulin also stimulates system A amino acid transport activity (205) in these cells by increasing the maximum transport capacity (V_{\max}) without any change in transporter affinity (K_m) (211) a process that is similar to that observed in freshly isolated rat skeletal muscle (210).

Vanadium, a trace element which in its +5 oxidation state as vanadate structurally resembles phosphate, is found in mammalian tissues (345). Its normal physiological role remains unknown. It has been demonstrated to interact in vitro with several enzymes and to have biological effects in cultured cells and intact animals. It inhibits the "P" type phosphorylated ATPases (369,370) and PTPs (374,375). In cultured cells it enhances protein tyrosine phosphorylation and has been documented to mimic a number of the metabolic actions

of insulin (347,351-353,421,434,471,472). This has led to its successful use as a therapeutic agent in various rodent models of diabetes (353,415,419-421,473-475) and recently to short term clinical studies in human subjects with both insulin-dependent (Type I) and noninsulin-dependent (Type II) diabetes mellitus (357,358).

It is previously reported that upon mixing hydrogen peroxide with vanadate a novel compound we termed pervanadate (aqueous peroxovanadium species) was formed (354). Pervanadate is a more powerful PTP inhibitor and also mimics a number of insulin's biological effects in target tissues (356,382,385,446,476). Most in vitro studies of the action of these PTP inhibitors have focused on glucose transport and metabolism and/or have been carried out in adipose tissue. To investigate whether vanadate and pervanadate can mimic other acute metabolic actions of insulin, particularly in muscle and to determine the potential role of tyrosine phosphorylation in the signalling of these actions the effects of these compounds on glucose and amino acid transport were examined in differentiated L6 skeletal muscle cells.

5.3 MATERIALS AND METHODS

5.3.1 Materials

Methylaminoisobutyric acid (MeAIB), ouabain and sodium orthovanadate were purchased from Sigma (St. Louis, MO). α [1- ^{14}C] MeAIB (48.4 mCi/mmol) was obtained from Dupont NEN (Boston, MA). All other reagents were obtained as described earlier in section 3.3.1.

5.3.2 Cell Cultures

L6 cells were grown as described in 3.3.2 and were used in the myotube stage. Well differentiated rat hepatoma cells (H411E) (kindly provided by Dr. D. Granner) were grown in DMEM in the presence of 10% FBS and 1% v/v antibiotic-antimycotic solution (stock: 10,000 units/ml penicillin, 10 mg/ml streptomycin, 25 mg/ml amphotericin B) in 6-well plates in a

humidified atmosphere of 5% CO₂: 95% air at 37°C and were used at approximately 80% confluency as judged by morphological criteria.

5.3.3 Drug treatment, glucose and amino acid uptake assay.

Stock solution of 25 mM vanadate was prepared in 50 mM HEPES buffer and subsequently was diluted using HEPES-buffered saline (HBS) solution (final concentrations: 140 mM NaCl, 5 mM KCl, 20 mM HEPES, 2.5 mM MgSO₄, 1 mM CaCl₂, pH 7.4) containing 5 mM glucose. Pervanadate solutions were prepared in the same buffer by mixing vanadate and H₂O₂ stock solutions as previously described (354). The final concentration of the drugs in the incubation medium and the time of incubation are indicated in each figure. At the end of the incubation period the medium was removed, the cells were rinsed twice with HBS solution and subsequently glucose and MeAIB uptake were measured with 10 μM 2-Deoxy-D-³H glucose (1mCi/ml) and 10 μM ¹⁴C-MeAIB respectively in the same buffer for 10 min at 23°C. To determine non-carrier mediated glucose and MeAIB transport, cytochalasin B and cold MeAIB respectively, were added to a final concentration of 10 mM each in parallel wells. The glucose and amino acid uptake assays were terminated as previously described in section 3.3.3 and cell-associated radioactivity was measured. Transport was determined as it is described before for glucose transport by subtraction of the non-specific from the total uptake. The nonspecific glucose and MeAIB uptake were less than 3% of total. The transport of both glucose and MeAIB were linear for at least 30 min under all conditions (data not shown).

5.3.4 Statistical analysis

The results are presented as means ± SE and the number of experiments is indicated in the legends to the figures. Statistical significance was assessed using Students paired t-test or analysis of variance (ANOVA) and differences accepted as significant at $p < 0.05$.

5.4 RESULTS

5.4.1 Effect of vanadate and pervanadate on glucose and amino acid uptake.

Exposure of L6 myotubes to vanadate (Fig 5.1A) or pervanadate (pV) (Fig. 5.1B) resulted in a time-dependent stimulation of 2-deoxyglucose uptake which reached a plateau at 90 min and 30 min respectively. Dose response curves revealed that vanadate stimulated 2-deoxyglucose uptake at 0.1 mM ($116 \pm 2.9\%$ of control, $p < 0.05$) reaching levels at 10 mM ($170.7 \pm 10.4\%$) which were similar to those seen with maximum insulin (10^{-7} M, 30 min) treatment ($167 \pm 11\%$) (Fig 5.2A). Maximum stimulation by pV was $171.7 \pm 12\%$. The difference between the dose-response curves of vanadate and pV to mimic insulin in L6 cells is similar to previous observations in rat adipocytes (382). Thus the concentration required for half maximum stimulation of glucose uptake was ~ 200 fold lower for pV (5 μ M) compared to vanadate (1.1 mM).

In contrast to the stimulating effect on glucose uptake both vanadate and pV caused a time- and dose-dependent inhibition of MeAIB uptake. Maximum inhibition was attained after 60 - 90 min (Figure 5.1). Significant inhibition was seen with 0.5 mM vanadate and maximum inhibition to $73.0 \pm 5.5\%$ of basal was reached with 10 mM. Concentrations of pV up to 10 μ M did not significantly alter basal MeAIB uptake. However pV concentrations of 50 μ M and above produced inhibition. At 500 μ M pV, MeAIB uptake was $22.7 \pm 6.5\%$ of control (Figure 5.2B). The half maximum concentration of pV required to inhibit basal MeAIB uptake was 70 μ M while that for vanadate was not measured directly since concentrations above 10 mM were not used to avoid cell toxicity. From the vanadate dose-response curve an estimate of 15 mM for the IC_{50} can be made. Thus the inhibitory effect of pV on MeAIB uptake was approximately 200-fold more efficacious than that of vanadate.

5.4.2 Effect of vanadate and pervanadate in combination with insulin.

To investigate the effect of vanadate and pV on insulin-stimulated glucose and amino acid uptake the effect of each agent in combination with insulin was examined. The cells were incubated with or without 5 mM vanadate or 100 μ M pV for a total of 90 min in the absence and

Figure 5.1 Effect of vanadate and pervanadate on glucose and amino acid transport. Time course

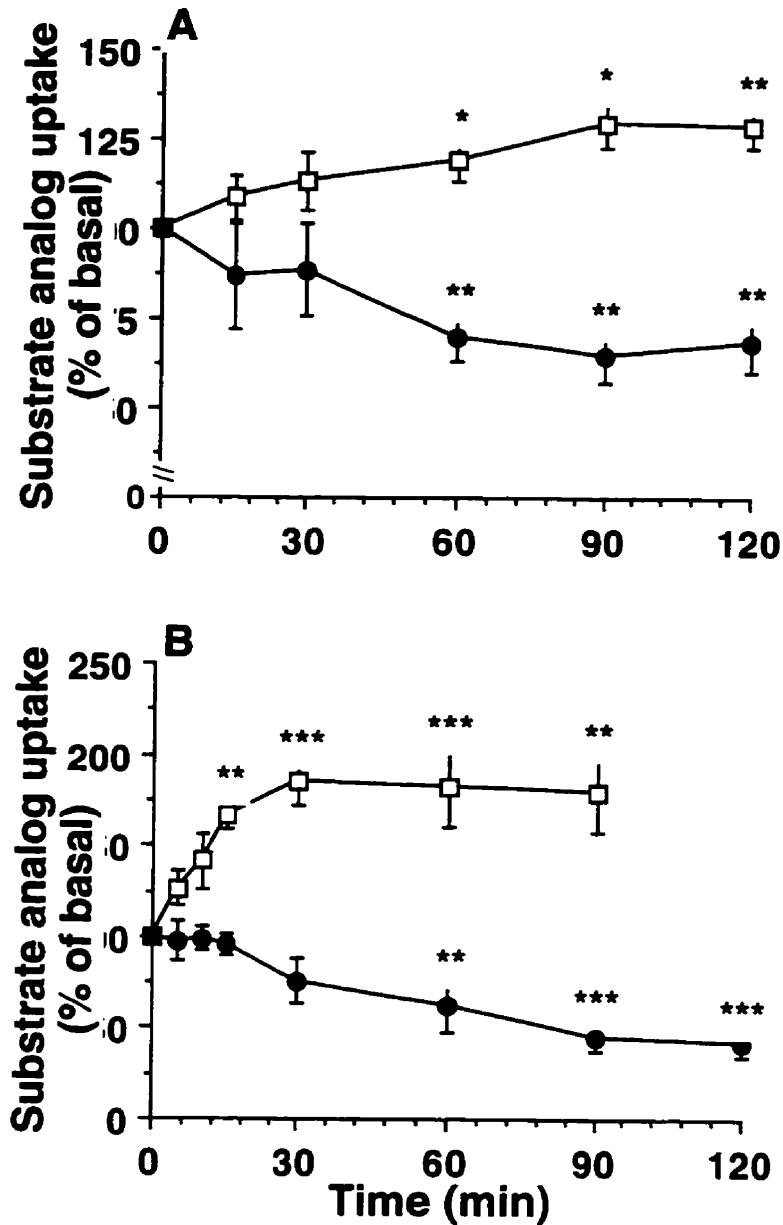

Differentiated L6 muscle cells were incubated with 5 mM vanadate (A) or 100 μ M pervanadate (B) for the indicated periods of time. At the end of the incubation 2-deoxyglucose (open squares) and MeAIB (closed circles) uptake were measured as described in Methods. The results are the mean \pm SE of 3 - 5 experiments performed in duplicate. Basal 2-deoxyglucose uptake was 9.98 ± 0.65 pmoles/mg/min and MeAIB uptake was 28.01 ± 3.5 pmoles/mg/min. * $p < 0.05$, ** $p < 0.01$, *** $p < 0.001$ compared with basal. Note the time-dependent stimulation of glucose transport and the inhibition of amino acid transport.

Figure 5.2 Effect of vanadate and pervanadate on glucose and amino acid transport. Dose-response

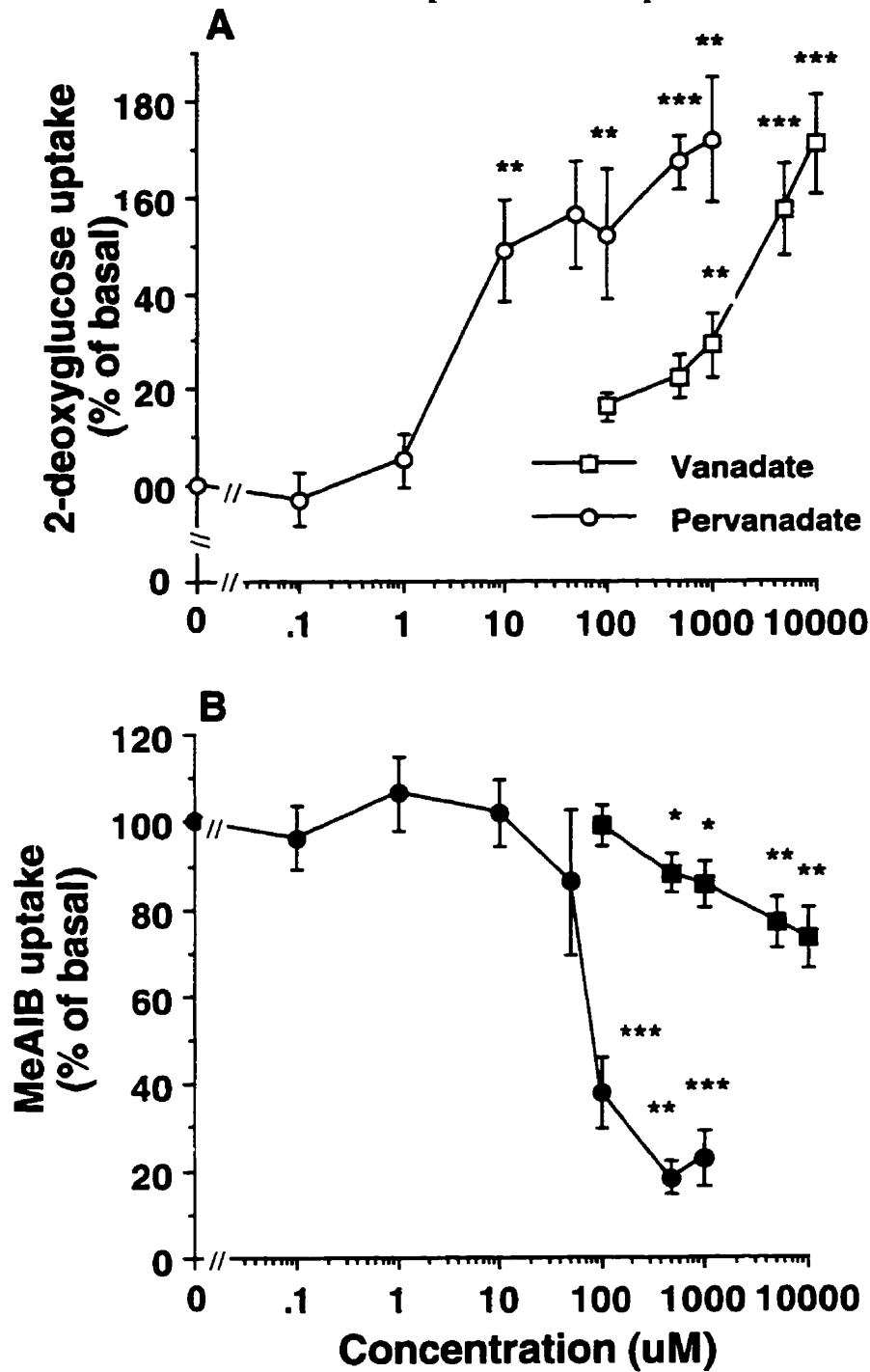

Cells were incubated for 90 min with the indicated concentrations of vanadate (closed squares) or pervanadate (closed circles) followed by measurements of glucose (A) and MeAIB (B) uptake. The results shown are the mean \pm SE of 4 - 9 separate experiments performed in duplicate. * $p < 0.05$, ** $p < 0.01$, *** $p < 0.001$ compared with basal. Both the stimulation of glucose transport and the inhibition of amino acid transport are dose-dependent.

presence of 10^{-7} M insulin during the final 30 min. The maximum responses of 2-deoxyglucose uptake to stimulation by vanadate and pV in combination with insulin ($191.4 \pm 20\%$ and $209.5 \pm 7.5\%$ of basal) were not different from that achieved after insulin alone ($194.8 \pm 10\%$) (Table 5.1). Similar results were obtained by addition of any concentration of the PTP inhibitors up to a maximum of 10 mM vanadate or 1 mM pV (data not shown). The lack of additivity between insulin at maximum stimulatory concentrations and vanadate or pV suggests that insulin and the PTP inhibitors mediate their effects via a common pathway or via different pathways which converge.

Insulin alone stimulated MeAIB uptake to $143 \pm 4.7\%$ of basal. In combination with 5 mM vanadate or 100 μ M pV insulin was no longer able to stimulate MeAIB uptake which was reduced to $97.8 \pm 7.2\%$ and $67.0 \pm 14.2\%$ of basal respectively (Table 5.1). Thus these concentrations of the PTP inhibitors completely abolished the insulin-stimulated component of amino acid uptake suggesting that insulin-stimulated MeAIB uptake is more sensitive than basal. A dose-response curve of inhibition of the insulin-stimulated component of MeAIB uptake by pV showed complete inhibition by 50 μ M and an IC_{50} of 10 μ M, a concentration 7-fold lower than the IC_{50} for inhibition of basal uptake (Figure 5.3). This sensitivity is similar to that found for stimulation of glucose uptake.

5.4.3 Effect of insulin and pervanadate on the kinetics of amino acid transport.

The decrease in amino acid transport in response to vanadate and pV could be due to a decrease in the maximum capacity of transport (V_{max}), a decrease in the affinity of the transport system for the amino acid, that is, an increase in the substrate concentration at which transport is half maximum (K_m) or both. To investigate these possibilities the effect of pV on the kinetics of MeAIB uptake was compared with that of insulin. It has been demonstrated previously that the rate of MeAIB uptake is linear for at least the first 20 min of incubation of L6 cells with 10-400 μ M MeAIB (211). A linear transformation of the uptake data at various concentrations of MeAIB

Table 5.1. Effect of vanadate and pervanadate (pV) on insulin-stimulated glucose and amino acid transport.

After 60 min treatment with 5 mM vanadate or 100 μ M pV, insulin (10^{-7} M) was added and the incubation of the cells continued for another 30 min in the same buffer. The results are the Mean \pm SE of 6 - 10 separate experiments performed in duplicate. *** $p < 0.001$ compared with basal. ^b $p < 0.001$ compared with insulin alone. Note that vanadate and pervanadate combined with insulin did not stimulate glucose transport over and above the levels seen with insulin alone while both agents completely inhibited the insulin-stimulated MeAIB uptake.

Treatment	2-Deoxyglucose uptake (% of basal)	MeAIB uptake (% of basal)
Insulin	194.8 \pm 10***	143.4 \pm 4.6***
Insulin + Vanadate	191.4 \pm 20***	97.8 \pm 7.2 ^b
Insulin + Pervanadate	209.6 \pm 7.5***	67.1 \pm 14.2 ^b

Figure 5.3 Dose-dependent inhibition of insulin-stimulated MeAIB uptake by pervanadate

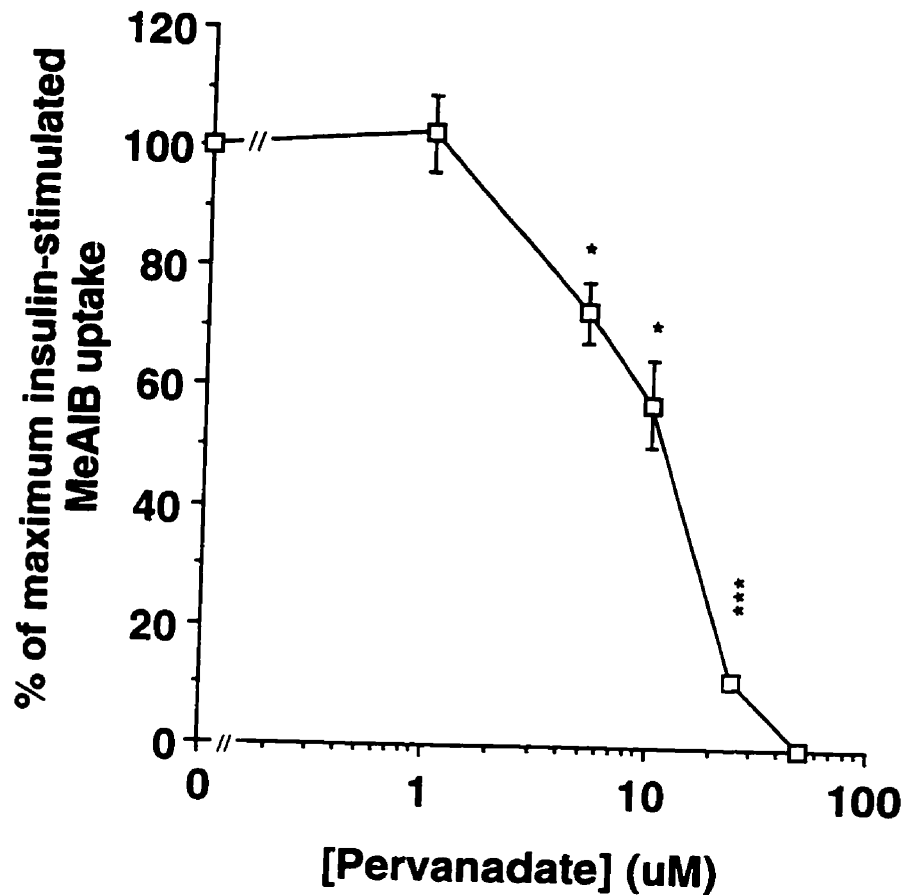

L6 cells were incubated with 0 - 100 μM pervanadate for a total of 90 min with the addition of 10^{-7}M insulin for the final 30 min. At the end of the incubation MeAIB uptake was measured as described in Methods. The results shown are the mean \pm SE of 3 - 4 experiments performed in duplicate. Insulin-stimulated MeAIB uptake in the absence of pervanadate was designated as 100%. * $p < 0.05$, *** $p < 0.001$. Note the dose-dependent inhibition of insulin-stimulated amino acid uptake by pervanadate.

(10–400 μM) was performed using a Hanes plot to allow a more accurate assessment of V_{max} and K_{m} . Insulin significantly increased the V_{max} of MeAIB transport as reported previously (211). Pervanadate (100 μM) completely abolished this increase. (V_{max} , pmoles/min per mg protein: control, 271; insulin, 385; pV + insulin, 199) (Figure 5.4). While insulin alone did not alter K_{m} , in the presence of pV K_{m} was increased (K_{m} , μM , control, 84; insulin 107; pV + insulin, 162). Kinetic analysis of MeAIB uptake performed with pV alone showed a small decrease in V_{max} (245 pmoles/min per mg protein) but more than a doubling of K_{m} (186 μM) compared to control (data not shown).

5.4.4 Effect of ouabain on basal and insulin-stimulated MeAIB uptake

Since vanadate has been reported to inhibit Na^+ , K^+ ATPase (369,370) we used ouabain, a widely used inhibitor at concentrations of 2 mM which have been reported to inhibit the Na^+ , K^+ ATPase (477). Ouabain did not inhibit MeAIB uptake. On the contrary, ouabain alone stimulated MeAIB uptake ($158.0 \pm 5\%$ of control) and augmented the stimulatory effect of insulin (insulin alone $143.4 \pm 4.6\%$ of control, insulin plus ouabain $208.0 \pm 3.5\%$) (Figure 5.5). Ouabain had no effect on the basal or insulin-stimulated glucose uptake (data not shown). These results suggest that vanadate and pV action is not related to inhibition of the Na^+ , K^+ ATPase.

5.4.5 Effect of vanadate on adaptive regulation of amino acid uptake

System A amino acid transport activity is increased in response to amino acid deprivation (205). This increase is referred to as adaptive regulation, occurs over several hours and appears to be dependent on protein synthesis. The effect of vanadate on adaptive regulation of system A activity was examined. L6 myotubes were deprived of all amino acids for up to 12 h. This resulted in a time-dependent increase in MeAIB uptake reaching ~5-fold that of control after 9–12 h of deprivation (Table 5.2). Vanadate, 500 μM , significantly reduced the increase in MeAIB uptake in response to amino acid deprivation. Amino acid deprivation for 12 h increased MeAIB uptake to $565.3 \pm 42\%$ of control in the absence but to only $237.7 \pm 28.4\%$ ($p < 0.02$) in the

Figure 5.4 Effect of insulin and pervanadate on the kinetics of amino acid transport in L6 muscle cells

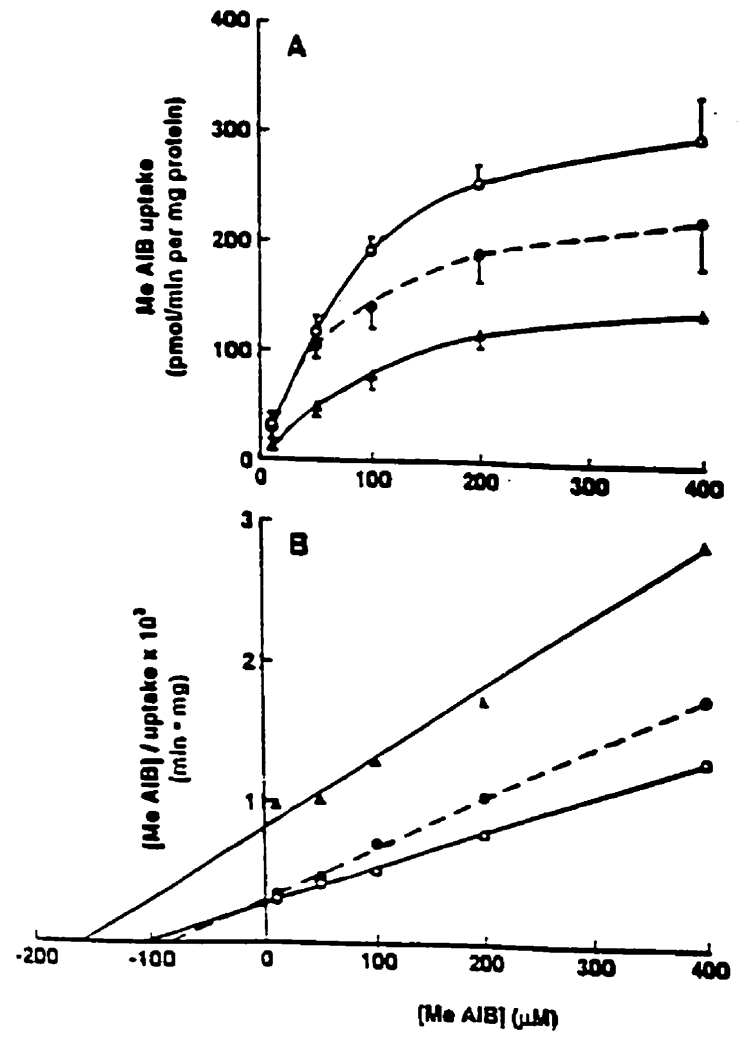

In control and pervanadate (100 μM) treated cells for 60 min, insulin (10⁻⁷M) or buffer alone were added and the incubation continued for a further 30 min. A. MeAIB uptake was measured as described in Methods in the presence of various concentrations (10 - 400 μM) of MeAIB. Control (closed circles), insulin (open circle), insulin plus pervanadate (closed triangle). Values for uptake in the presence of pV alone overlapped substantially with those in the presence of both pV plus insulin and were omitted for clarity. The results shown are the mean ± SE of 3 separate experiments performed in duplicate. B. Linear Hanes transformation of the data presented in A. (see text for numerical values of Km and Vmax).

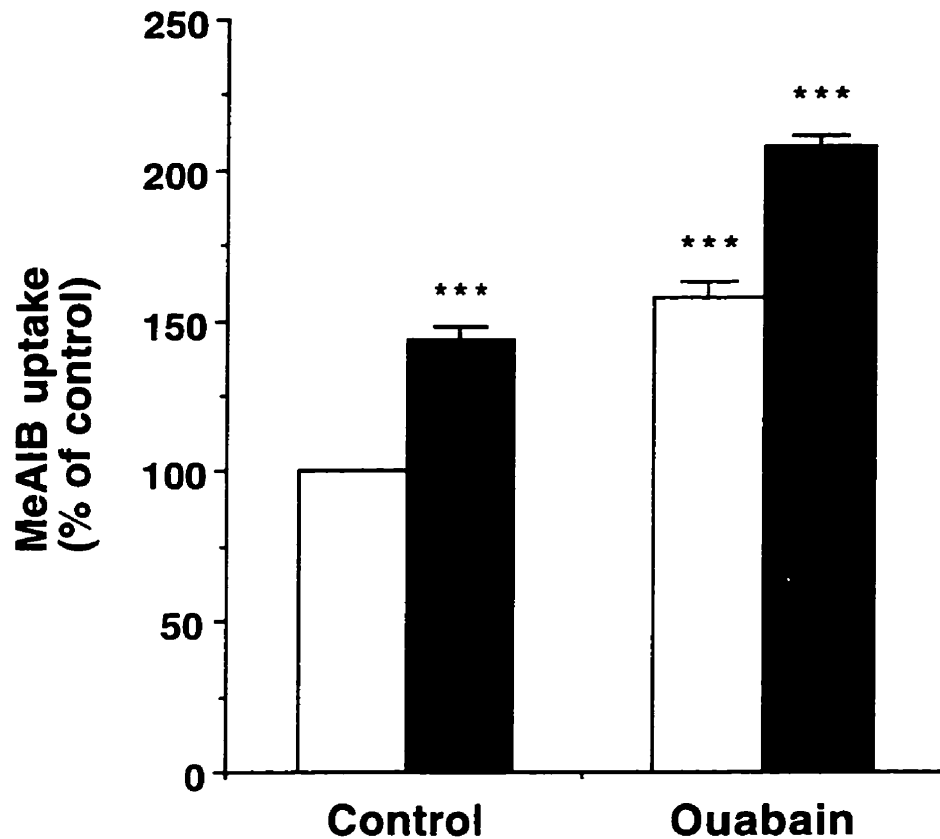
Figure 5.5 Effect of ouabain on basal and insulin-stimulated MeAIB uptake

Cells were treated with 2 mM ouabain for 90 min at 37°C in the absence (open bars) and the presence (shaded bars) of insulin (10^{-7} M) added during the final 30 min of this incubation. Values are the mean \pm SE of 3 separate experiments performed in duplicate. *** $p < 0.001$ compared with untreated control. Note that in contrast to vanadate and pervanadate, ouabain did not inhibit basal or insulin-stimulated MeAIB uptake (see Figure 5.2 and Table 5.1).

Table 5. 2. Effect of vanadate on adaptive regulation of system A amino acid transport.

Myotubes were incubated for the time indicated in HBS buffer containing 5 mM glucose in the presence and absence of amino acids and in the presence and absence of 500 μ M vanadate. The results are the Mean \pm SE of 3 -4 separate experiments performed in triplicate. MeAIB uptake is expressed as percent of control cells not deprived of amino acids which were assayed in parallel in the same experiment. Basal MeAIB uptake in the presence of amino acids (Time 0) was inhibited by vanadate to 88.1 ± 4.3 % of that in the absence of vanadate and was designated as 100 % at 0 h for + vanadate. In these experiments insulin stimulated MeAIB uptake to 166.1 ± 12.8 % of control. ** $p < 0.02$, *** $p < 0.01$ compared to -vanadate. * $p < 0.05$, ^b $p < 0.001$ compared to control.

Time (h)	MeAIB uptake (% of control)		2-Deoxyglucose uptake (% of control)
	- Vanadate	+ Vanadate	+ Vanadate
0	100	100	100
3	164.1 ± 25.2	144.2 ± 16.5	$152.7 \pm 19.6^*$
6	331.7 ± 18.4^b	$231.3 \pm 15.8^{**}$	192.4 ± 13.6^b
9	465.4 ± 43.4^b	$274.3 \pm 30.5^{***}$	215.7 ± 15.0^b
12	565.3 ± 42.0^b	$237.7 \pm 28.4^{**}$	226.7 ± 43.9^b

presence of vanadate. Under these conditions there was no cell toxicity observed by trypan blue exclusion and vanadate stimulation of 2-deoxyglucose uptake was maintained (Table 5.2).

5.4.6 Effect of cycloheximide on PTP inhibitor action

Since adaptive regulation has been shown to require protein synthesis it was tested whether the more acute (up to 90 min) actions of vanadate and pV described above require protein synthesis by using cycloheximide, a protein synthesis inhibitor. Previously it was demonstrated that 1 mg/ml cycloheximide inhibits protein synthesis in L6 myotubes (478). Coincubation with cycloheximide had no effect on the ability of insulin, vanadate or pV to either stimulate glucose or stimulate/inhibit amino acid uptake (Table 5.3) indicating that the mechanism of action of vanadate and pV is independent of protein synthesis.

5.4.7 Effect of vanadate and pervanadate on MeAIB uptake in hepatoma cells

The L6 muscle cell line was originally derived from rat neonatal tissue (219) and may represent a unique insulin target cell. To determine whether the inhibitory action of vanadate and pV on MeAIB uptake was a response confined to L6 muscle cells the effects of the two agents were examined in the well differentiated cultured hepatoma cell line, H4IIE. Insulin (10^{-7} M for 30 min) stimulated MeAIB uptake to $152.9 \pm 12\%$ of control. Vanadate at concentrations of 0.1 to 10 mM did not significantly lower basal amino acid uptake although a tendency towards inhibition was observed at the higher concentrations (data not shown). However insulin-stimulated MeAIB uptake was completely inhibited by 0.5 mM vanadate (Figure 5.6). Pervanadate at 500 μ M decreased basal MeAIB uptake which did not reach statistical significance but completely abolished insulin-stimulated MeAIB uptake ($76.8 \pm 9.3\%$ of basal, $p < 0.001$) (Figure 5.6). Neither agent affected glucose uptake in hepatoma cells under these conditions (data not shown).

Table 5.3. Effect of cycloheximide on insulin, vanadate and pervanadate induced changes in glucose and amino acid uptake.

Insulin (10^{-7} M for 30 min), vanadate (10 mM for 60 min) or pervanadate (500 μ M for 60 min) were used to treat cells in the absence and the presence of 1 μ g/ml cycloheximide. The results shown are from one of 3 experiments with similar results. Note that cycloheximide did not abolish the responses of the cells to any of the agents used.

Treatment	2-Deoxyglucose uptake (% of control)		MeAIB uptake (% of control)	
	-	+	-	+
Cycloheximide	-	+	-	+
Control	100	105.8	100	92.3
Insulin	242.5	247.8	158.4	157.1
Vanadate	152.2	150.6	76.9	76.3
Pervanadate	267.0	255.0	39.1	35.6

Figure 5.6 Effect of vanadate and pervanadate on basal and insulin-stimulated MeAIB uptake in hepatoma cells

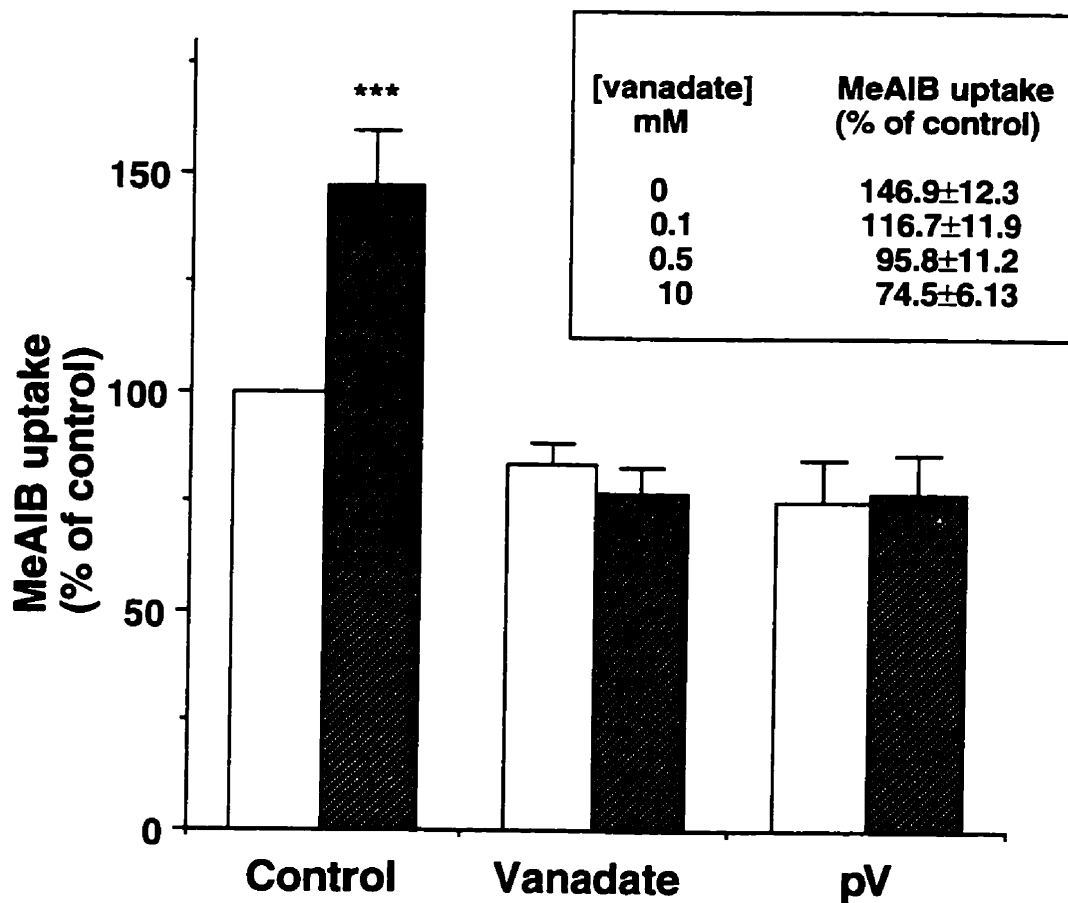

Hepatoma cells (H4IIE) at 80% confluency were incubated with 10 mM vanadate or 500 μ M pervanadate (pV) for 90 min at 37°C in the absence (open bars) and presence (shaded bars) of 10^{-7} M insulin during the final 30 min. MeAIB uptake was assayed as described in Methods for the L6 myotubes. Uptake was linear for at least 30 min under these conditions. The results shown are the mean \pm SE of 3 separate experiments performed in duplicate. Inset: dose-dependent inhibition of insulin-stimulated MeAIB uptake by vanadate. *** $p < 0.001$ compared with control.

5.5 DISCUSSION

In the study presented here it was found that vanadate and pV mimic insulin to stimulate glucose uptake in cultured differentiated L6 skeletal muscle cells, a cell line which has been used extensively as an in vitro model of a major insulin target tissue. The relative efficacies of vanadate and pV were similar to those previously found in rat adipocytes (382) and correlate with their relative potencies to inhibit PTPs (356,382). In contrast to these actions on glucose uptake and to the action of insulin, both vanadate and pV inhibited MeAIB uptake. MeAIB is an amino acid analog which is specifically transported by the insulin-sensitive system A amino acid carrier. Therefore the data indicate a paradoxical effect of these PTP inhibitors to inhibit this insulin biological response. Although previous studies in cultured L6 cells have not been performed, vanadate and peroxovanadium have been demonstrated to have insulin-mimetic actions in rat skeletal muscle (385,387,476,479). Thus glucose uptake, glycogen synthesis and lactate production were stimulated, but stimulation of protein synthesis and inhibition of proteolysis could not be demonstrated (385,387). Amino acid transport was examined in one study by Munoz et al (388) who found that in freshly isolated rat epitrochlearis muscle MeAIB uptake was increased by vanadate. An attempt to define the mechanism suggested that the stimulation was mediated by an alteration of intracellular pH rather than via a stimulation of the insulin signalling pathway. In view of these different results it was asked whether L6 cells have a unique response to vanadate. Both vanadate and pV also inhibited insulin-stimulated MeAIB uptake in H4IIE hepatoma cells. Thus other than the model systems used, there is no explanation for the different results since even at the high concentrations of vanadate employed by Munoz et al, no stimulation of MeAIB uptake was observed in the present study.

The mechanism of the insulin-like effects of vanadate and pV remain controversial. Vanadate can interact directly with and inhibit a number of enzymes such as P-type phosphorylated ATPases (366,369,370), glucose-6-phosphatase (377) and PTPs (364,374,375). Previous studies suggested that inhibition of Na⁺, K⁺ ATPase is not the mechanism of action and that this inhibition may not occur in intact living cells exposed to

vanadate (351,370). Whether the insulin receptor itself or another tyrosine kinase or both are responsible remains controversial (438,439,446,480). The importance of tyrosine phosphorylation in the signalling of insulin biological effects is well established (4,29). Insulin-stimulated receptor tyrosine autophosphorylation and subsequent tyrosine phosphorylation of IRS-1/IRS-2 are two early events in the signal transduction pathway (2,4,10). Inhibition of PTP activity by agents such as vanadate and pervanadium is thought to be the major mechanism by which these agents mimic many of the actions of insulin both in vitro and in vivo (347,356,364,374,375,382,433).

The mechanism of the inhibition of amino acid uptake by vanadate and pV is not known. Neither protein synthesis nor inhibition of the Na⁺, K⁺ ATPase appeared to be required. There are three findings in this study which suggest that two mechanisms for the inhibitory action may be involved. First the inhibition of basal as compared with insulin-stimulated MeAIB uptake manifested different sensitivity to vanadate and pV. The IC₅₀ for inhibition of basal uptake was 70 μM for pV and estimated to be 15 mM for vanadate, both ~ 14-fold greater than the concentrations required to stimulate glucose uptake. In contrast the insulin-stimulated component of MeAIB uptake was inhibited at lower concentrations (IC₅₀ for pV, 10 μM). Second the inhibitory effect of pV on MeAIB uptake was associated with both a decrease in V_{max} as well as an increase in K_m. In the basal state the predominant effect was an increase in K_m while inhibition of insulin-stimulated MeAIB uptake by pV was associated with a marked decrease in V_{max}. Finally, MeAIB uptake stimulated by amino acid deprivation was also inhibited by vanadate suggesting an effect that was independent of the insulin signalling pathway.

Several actions of insulin have now been found not to be stimulated by vanadate in some tissues. Bosch et al reported that in isolated rat hepatocytes glycogen synthase was inactivated and glycogen phosphorylase was stimulated by vanadate (386). However the concentrations used were very high, 8 mM, and Bruck et al demonstrated an inhibition of hepatic glucose output in perfused rat liver by much lower concentrations (481). In skeletal muscle the concentrations of vanadate (385,388) and pervanadate (476,482) required to promote insulin biological effects are

higher than those required in adipocytes (354,433,442). However at the same concentrations that stimulate glucose uptake and metabolism, the insulin-like effects on protein metabolism are not mimicked (387). The results from the study presented here showing that glucose uptake is increased but insulin-stimulated amino acid uptake is inhibited at similar concentrations and that the relative potencies of vanadate and pV for the two effects are also similar suggest that inhibition of PTPs may be involved in both actions. A number of recent studies indicate the importance of PTP activity not only in termination or dampening of growth factor signalling but also in signal propagation. In the case of insulin the SH2-domain containing PTP, PTP1D/SYP/SHPTP2, has been found to play a role in the mitogenic response (398,483). Since vanadate and pV are relatively nonspecific in their PTP inhibitory actions, it is conceivable that insulin actions requiring PTP activity may be inhibited. Presently little is known about the regulation of system A amino acid transport and the mechanism by which insulin exerts its stimulatory effect. Further work is required to determine whether PTP action is required. Vanadate and its various derivatives have been used successfully in various rodent models of diabetes mellitus and proposed as potential therapeutic agents in humans (347). Recent studies in humans *in vivo* (357,358) and in human skeletal muscle *in vitro* (425) have demonstrated effects of vanadate on glucose metabolism but effects on amino acid and protein metabolism remain to be determined.

It should be mentioned that measurements of glucose and amino acid uptake in all the experiments presented in this section were performed simultaneously. Under exactly the same conditions where an inhibition of amino acid transport was observed with vanadate and pV the transport of glucose was increased suggesting that the inhibitory effect seen was not associated with cell toxicity. The morphology of the cells, as examined under a light microscope, was not affected by vanadate and pV treatment as was indicated by the appearance of normal healthy cells identical to control. Furthermore, cell viability, as measured by trypan blue staining, was not affected by vanadate and pV treatment. It is possible that muscle cells do not take up vanadate and pV as other cells do and for this reason high concentrations of the compounds are required in order to see an effect. It should be kept in mind however that similarly high

concentrations are also required in isolated muscle preparations for an effect of these compounds to be observed (385,388)(378,381,469).

In summary, it is shown in the results presented here that although the PTP inhibitors vanadate and pervanadate increase glucose uptake in L6 myotubes, they inhibit amino acid uptake in a concentration-dependent manner.

5.6 CONCLUSIONS

It is concluded that the PTP inhibitors vanadate and pervanadate mimic insulin action with regard to glucose uptake but have actions opposite to insulin with regard to amino acid uptake in L6 cells.

CHAPTER 6

MECHANISM OF ACTION OF VANADATE AND PERVANADATE TO STIMULATE GLUCOSE UPTAKE IN MUSCLE CELLS

6.1 ABSTRACT

Vanadate and pervanadate (pV) are PTP inhibitors which mimic insulin in stimulating glucose transport. However, their mechanism of signal transduction is not defined. In this study the role of PI 3-kinase, known to be required for insulin-stimulated glucose transport, MAPK kinase (MEK) and PKC in the stimulation of glucose uptake by the two agents was examined. In L6 myotubes vanadate and pV stimulated glucose transport to levels similar to insulin ($178 \pm 5.7\%$ of control). The PI 3-kinase inhibitor wortmannin (WM) blocked insulin stimulation of glucose transport ($117.0 \pm 12.3\%$ of basal) but it did not alter significantly the response to vanadate or pV ($152 \pm 12.3\%$ and $240 \pm 9.2\%$ of basal respectively in the presence of WM). Vanadate and pV induced an increase in PI 3-kinase activity associated with phosphotyrosines to levels comparable to that of insulin, as detected by anti-phosphotyrosine immunoprecipitations, and this increase was blocked by wortmannin. Furthermore, pretreatment of myotubes with WM was effective in abolishing vanadate, pV and insulin stimulated production of PI(3,4,5)P₃ and PI(3,4)P₂, in intact cells. Pretreatment of myotubes with the recently identified inhibitor of MEK, PD098059, did not alter the vanadate- and pV- stimulation of glucose uptake. Acute stimulation of L6 cells with phorbol myristate acetate (PMA) resulted in an increase in glucose transport which was blocked after PKC downregulation by chronic incubation with PMA. In contrast the stimulation by vanadate and pV was not changed by PKC downregulation nor by pretreatment of myotubes with the PKC inhibitors calphostin C or bisindolylmaleimide (BIM). Disassembly of the actin network of myotubes with cytochalasin D (CD) was shown to block the insulin stimulation of glucose transport. The role of the actin network in the vanadate and pV stimulation of glucose transport was examined. CD pretreatment of myotubes inhibited glucose uptake in response to both vanadate and pV suggesting that an intact actin network is required for the response of the cells to vanadate and pervanadate. These data suggest that in contrast to insulin, vanadate and pV stimulate glucose transport in L6 skeletal muscle cells by a mechanism independent of PI 3-kinase activation. PKC and MEK also do not appear to be involved in the mechanism of action of vanadate and pV. However, similar to insulin, the mechanism of

regulation of glucose transport by vanadate and pV appears to require the presence of an intact actin network. In conclusion, vanadate and pV may mimic insulin to stimulate glucose transport by using an alternate pathway to signal events downstream of PI 3-kinase.

6.2. INTRODUCTION

As it is shown in chapter 5 vanadate and pervanadate stimulated glucose uptake in L6 skeletal muscle cells to levels similar to that of insulin. Insulin increases glucose uptake in skeletal muscle by inducing the translocation of glucose transporters from an intracellular compartment to the cell surface (discussed in 1.3.2.2) The mechanism by which this translocation of glucose transporters is regulated remains poorly understood. The insulin signalling cascade is initiated by the activation of the tyrosine kinase of the insulin receptor leading to tyrosine phosphorylation of intracellular proteins such as insulin receptor substrate 1 (IRS-1), which acts as a docking site for proteins containing SH2 domains (reviewed in 1.2.2). Phosphatidylinositol 3-kinase (PI 3-kinase) through the SH2 domain of its p85 regulatory subunit binds to IRS-1. This results in increased activity of the p110 catalytic subunit which phosphorylates inositol phospholipids on the D3 position (4,45,71). Recently (as discussed in section 1.3.2.4.1.1) it was demonstrated that the fungal metabolite wortmannin (WM) inhibits both PI 3- kinase activity and the insulin-induced increase in glucose transport in rat adipocytes (61), 3T3L1 adipocytes (63) as well as in rat skeletal muscle (60) and L6 muscle cells (65). PI 3-kinase plays an important role in this insulin-signalling pathway. Similarly, overexpression of a mutant p85 which fails to bind the p110 catalytic subunit blocked both insulin stimulated PI 3-kinase activation and glucose uptake (171). These data strongly support the concept that PI 3-kinase plays an important role in this insulin signalling pathway. PI 3-kinase phosphorylates inositol phospholipids on the D3 position (45). The major *in vivo* substrate has been determined to be PI (4,5) P₂ and the product PI (3,4,5) P₃. A second intracellular product, PI (3,4) P₂ may be derived from dephosphorylation of the former substrate. Additionally, PI (3,4) P₂ may be derived from phosphorylation of PI (4) P by PI 3-kinase. The biochemical events involved in

the stimulation of glucose transport by insulin subsequent to PI 3-kinase remain poorly defined. One downstream requirement appears to be an intact actin network since its disruption by CD inhibits insulin-stimulated glucose uptake (185). It is demonstrated in chapter 5 that vanadate and pervanadate stimulate glucose uptake in L6 cells to a similar extent as insulin. Paquet demonstrated that the acute stimulation of glucose uptake by vanadate in 3T3 L1 adipocytes was associated with glucose transporter translocation similar to insulin (452). In the present study the role of PI 3-kinase was examined and found that the insulin-mimetic agents can stimulate glucose transport independent of PI 3 kinase. Furthermore, it was found that neither MAPKK (MEK) nor PKC appear to be involved. Finally, all the stimuli, insulin, vanadate and pV do require an intact actin network to stimulate glucose uptake.

6.3. MATERIALS AND METHODS

6.3.1. Materials

Phorbol myristate acetate (PMA), wortmannin and cytochalasin D were purchased from Sigma (St.Louis, MO). Anti-phosphotyrosine antibody coupled to agarose beads was purchased from UBI (Lake Placid,NY). ^{32}P i and $\gamma\text{-}^{32}\text{P}$ -ATP were obtained from Amersham (Oakville, ON, Canada). Oxalate treated thin layer chromatography (TLC) plates were obtained from Analtech (Newark,DL) and purified L- α -phosphatidylinositol was purchased from Avanti Polar Lipids (Alabaster, AL). Calphostin C and Bisindolylmaleimide (BIM) were obtained from Calbiochem (San Diego, CA). PD 098059 was a gift from Dr. A. Saltiel (Parke Davis, MI). All other reagents were obtained as described in 3.3.1.

6.3.2. Cell cultures

L6 cells were grown as previously described (3.3.2). All experiments were carried out with fully differentiated myotubes. The cells were grown in 6-well plates for the transport experiments and in 10 cm-diameter dishes for immunoprecipitations and PI 3-kinase activity measurements as well as for ^{32}P labeling experiments.

6.3.3. Drug treatment and glucose uptake assay

Solutions of vanadate and pervanadate were prepared as previously described (5.3.3). Wortmannin and cytochalasin D stock solutions were prepared in DMSO. Cells were exposed to the different agents and to insulin in Hepes buffered saline solution (HBS, see section 3.3.3) containing 5 mM glucose. The final concentration of the drugs in the incubation medium and the time of incubation are indicated in each figure. In the experiments with wortmannin the cells were exposed to 100 nM wortmannin for the time indicated in each figure before the addition of insulin, vanadate or pervanadate and throughout the stimulation period. For the PKC downregulation experiments the cells were pre-incubated with or without 100 nM PMA for 24 hours in α -MEM. At the end of this period PMA was removed, the cells were washed with HBS (containing 5 mM glucose) buffer twice and then incubated with or without insulin, vanadate, pervanadate or PMA. For the acute stimulation with PMA the cells were exposed to 1 μ M PMA for 1 hour. In the experiments where the PKC inhibitors calphostin C and BIM were used, the cells were incubated with the inhibitors (at concentrations given in each figure) for 1 hour before the addition of vehicle, insulin, vanadate or pervanadate. The same volume of diluent (DMSO) was added to cells not treated with wortmannin, calphostin C and BIM to match the DMSO concentrations in the cells treated with these inhibitors. At the end of the incubation period the medium was removed, the cells were rinsed twice with HBS solution and glucose uptake (2DG uptake) was measured immediately as described in sections 3.3.3. and 5.3.3. for 10 min.

6.3.4. Immunoprecipitations

Myotubes were incubated for 18 h in low serum (0.1 %)-containing medium and then were treated with the different agents as described above. After the drug treatments the cells were immediately washed once with ice-cold phosphate buffered saline containing 100 μ M Na_3VO_4 and twice with buffer A (20 mM HEPES, 137 mM NaCl, 1 mM MgCl_2 , 1 mM CaCl_2 , 100 μ M Na_3VO_4 , pH 7.5) and then lysed in 1 ml of lysis buffer (buffer A containing 10% glycerol, 1 %

NP40 and 2 mM PMSF). The cell lysate was spun at 16,000rpm for 10 min at 4 °C and the supernatants were incubated overnight with anti-phosphotyrosine antibody coupled to agarose beads (25 µl to 1 ml sample was added) which had been washed twice with PBS and preincubated with lysis buffer containing 10 % BSA. The immunocomplexes were used for in vitro PI 3 -kinase activity.

6.3.5. In vitro PI3 Kinase activity assay

The immunocomplexes were washed 3 times with solution I (PBS containing 1 % NP40 and 100 µM Na₃VO₄, pH 7.5), 3 times with solution II (0.5 M LiCl, 0.1 M Tris, and 100 µM Na₃VO₄, pH 7.5), 2 times with solution III (10 mM Tris, 100 mM NaCl, 1 mM EDTA and 100 µM Na₃VO₄, pH 7.5) and then were incubated for 5 min with 50 µl of solution III, 10 µl of 100 mM MgCl₂ and 20 µg of PI resuspended by sonication in 10 µl of 10 mM Tris pH 7.5 and 1 mM EGTA. The reaction was initiated by the addition of 5 µl of 1 mM γ-³²P-ATP (10 mCi/ml) in 20 mM MgCl₂ and terminated after 10 min at 23 °C with the addition of 20 µl of 6 M HCl. Lipids were extracted with 160 µl of CHCl₃:MeOH (1:1) followed by centrifugation for 10 min at 16,000 rpm. To separate the lipids 50 µl of the extracted lower phase were applied to TLC plates that had been prebaked at 110 °C for 1 hour. The lipids were separated with CHCl₃:MeOH: H₂O: NH₄OH ((ml) 60:47:11.6:2) and detection and quantitation of ³²P-PI3P was determined by densitometry using a Molecular Dynamics PhosphorImager System.

6.3.6. Determination of PI 3 kinase lipid products in intact cells

Myotubes grown in 10 cm-diameter dishes were incubated overnight in media containing 0.1 % FBS followed by incubation for 4 h in phosphate free medium supplemented with 0.5 % BSA and containing ³²Pi to a final concentration of 250 µCi /ml. The cells were rinsed 3 times with HBS containing 5 mM glucose and then were stimulated with the concentrations and for the times indicated with insulin, vanadate and pV in the same buffer. At the end of the incubation the buffer was rapidly aspirated and 1 ml of ice-cold 2.4 M HCl was added to each dish. The cells were scraped and transferred to 5 ml polypropylene tubes. Ice-cold chloroform (CHCl₃) (1ml)

was added followed by 1.5 ml of CHCl₃/methanol (MeOH) (1/2 (v/v)). The samples were vortexed thoroughly and spun at 1500 rpm at 4 °C for 5 min to separate the organic and aqueous phase. The lower organic phase was aspirated and the remaining aqueous phase was similarly extracted twice more and all 3 lipid extracts were pooled and dried under nitrogen (N₂). The dried lipids were redissolved in 50 µl of CHCl₃/MeOH (1:1, v/v), and then resolved by thin layer chromatography. ³²P-labeled lipids were visualized by autoradiography, and deacylated without elution from silica (C). The resulting glycerol phosphoinositol polyphosphate species were separated by HPLC on a Whatman Partisphere 5 SAX 25 cm column. Quantitation of eluting [³²P] was performed using a radioisotope flow detector (Beckman model 171). Retention times have been determined by comparison with ³H standards of glycerol phosphoinositol polyphosphates and inositol polyphosphates.

6.4. RESULTS

6.4.1. Effect of wortmannin on insulin- vanadate- and pV-stimulated glucose uptake

As previously demonstrated in chapter 5 (Figures 5.1 and 5.2) vanadate and pV stimulated glucose transport into L6 myotubes in a time- and dose-dependent manner. In the set of experiments presented here, maximum stimulation reached levels similar to that achieved with maximum insulin. (% of basal; Insulin (100 nM), 178±5.8%; vanadate (5 mM), 144±8.5 %; pV (100 µM) 179±3.9 %) (Figure 6.1).

To determine the role of PI 3-kinase, L6 myotubes were exposed to 100 nM insulin (30 min), 5mM vanadate or 100 µM pV (60 min), in the absence and presence of 100 nM wortmannin which was added for 35 min prior to insulin and 5 min prior to vanadate and pV so that the duration of wortmannin treatment was identical in all groups. Wortmannin significantly inhibited basal glucose transport to 58.6±2.0 % of control (p<0.001), as previously reported (65). Thus the ability of the agents to stimulate glucose uptake in the presence of wortmannin was expressed as a percent of the basal transport in the presence of wortmannin. Stimulation of

Figure 6.1 Effect of insulin, vanadate and pV on glucose transport in muscle cells

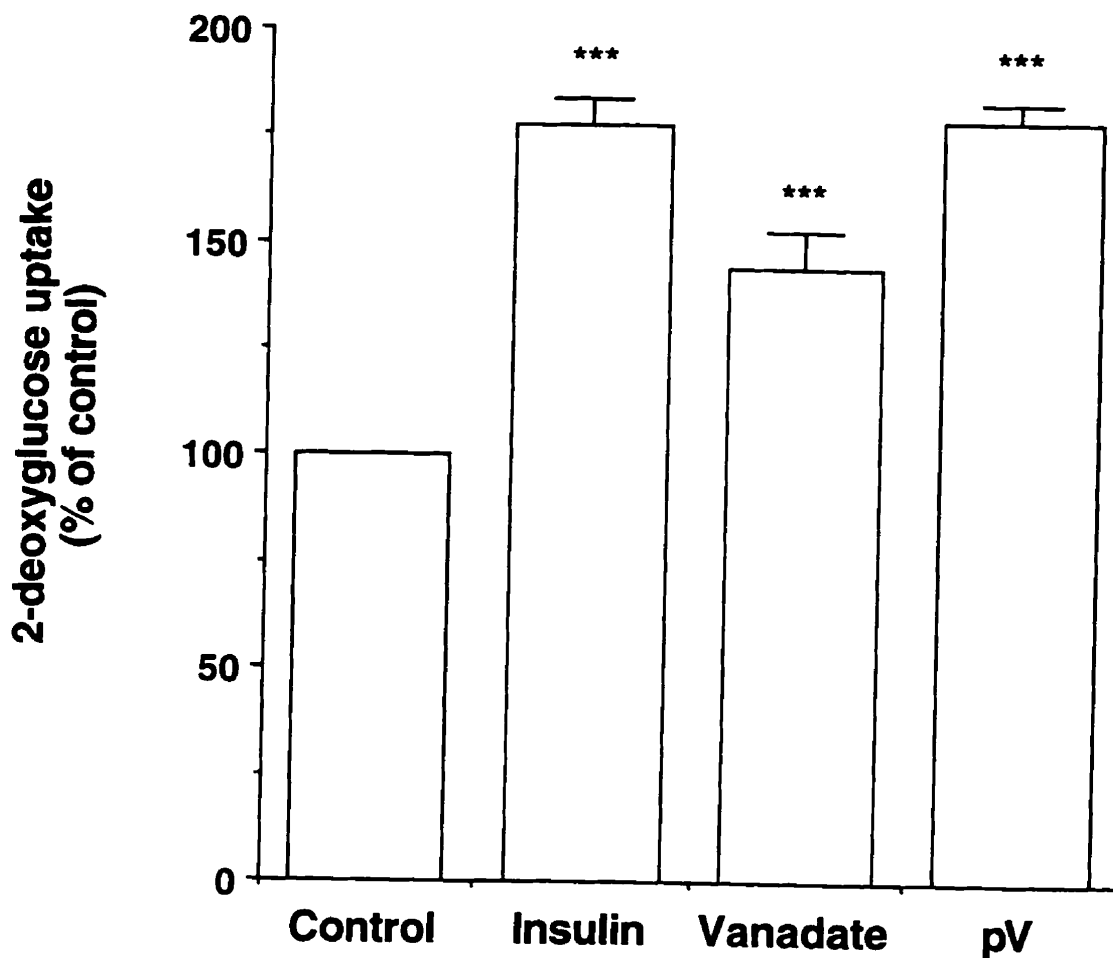

Vanadate and pV increased glucose transport into cells to levels similar to that reached by insulin. Treatment of cells with vanadate (5 mM) or pervanadate (100 μ M) for 90 min, with insulin (100 nM) for 30 min. The results are the mean \pm SE of 4-8 experiments performed in duplicate. ***, $p < 0.001$ compared to untreated control. Basal 2-deoxyglucose uptake was 10.5 ± 1.5 pmoles/mg/min.

glucose transport by insulin was inhibited by wortmannin (117 ± 5.3 %, NS compared to basal), while stimulation by vanadate (144.4 ± 8.5 %, $p < 0.05$) and pV (240.3 ± 9.2 %, $p < 0.01$) was not affected (Figure 6.2). It should be noted that higher concentrations of wortmannin up to $1 \mu\text{M}$ also did not result in any inhibition of glucose transport by vanadate or pV (data not shown), nor did longer incubation time (wortmannin added 30 min instead of 5 min prior to the addition of vanadate or pV) (data not shown). These results suggested that in contrast to insulin, vanadate and pV are able to increase glucose transport in L6 muscle cells independent of PI 3-kinase.

6.4.2. Wortmannin blocks in vitro PI 3-kinase activity

To determine whether vanadate and pV were in fact activating PI 3-kinase in myotubes and that any activation was blocked by wortmannin, PI 3-kinase activity was measured in vitro in anti-phosphotyrosine immunoprecipitates. L6 myotubes were treated with 100 nM insulin, 5 mM vanadate or $100 \mu\text{M}$ pV for 15 min following which the cells were solubilized and total lysates were subjected to immunoprecipitations with anti-phosphotyrosine antibody and PI 3-kinase activity was measured as described in Methods. Insulin, vanadate and pV increased PI 3-kinase activity to a similar extent (2-2.5 fold compared to untreated control). pV increased PI 3-kinase activity with a time-course similar to that of insulin reaching maximum levels within 5 min while activation by vanadate was somewhat slower and maximum levels were reached within 15 min (data not shown). Pretreatment with 100 nM wortmannin inhibited basal PI 3-kinase activity and abolished the increase induced by insulin and pV (Figure 6.3). Wortmannin also abolished the increase in PI 3 kinase activity in response to vanadate (not shown).

6.4.3. Generation of the PI 3-kinase lipid products in intact cells

To confirm the validity of the results of the PI 3-kinase assays described above, the effects of insulin, vanadate and pV on the PI 3-kinase activity in situ was determined by measurement of the synthesis of the lipid products. Serum deprived myotubes were labeled with ^{32}P for 4 hours followed by stimulation with insulin, vanadate and pV in the absence and the presence of 100 nM wortmannin as described above. Insulin, vanadate and pV all increased the

Figure 6.2 Effect of wortmannin on insulin, vanadate and pV stimulation of glucose transport in myotubes

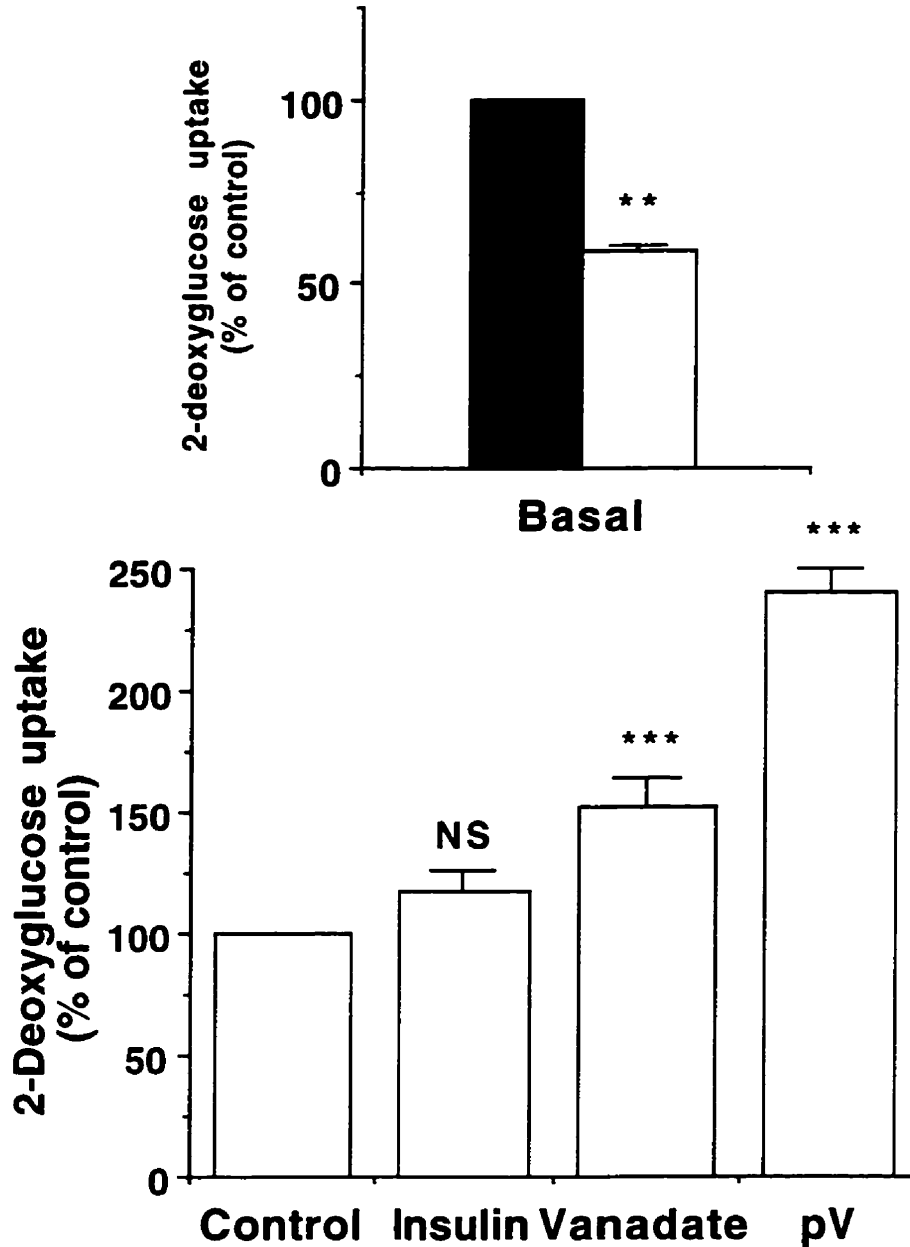

Myotubes were incubated without or with 100 nM wortmannin for 35 min followed by the addition of insulin (10^{-7} M) for 30 min, and 5 min with wortmannin followed by addition of vanadate (5 mM) or pV (100 μ M) for 60 min and glucose transport was measured as described in Methods. The results are the mean \pm SE of 3-4 experiments performed in duplicate and are expressed as percent of basal uptake in the presence wortmannin. The effect of wortmannin on basal glucose transport is shown in the inset (control: shaded bar, wortmannin: open bar). (**, $p < 0.01$ compared to control in the absence of wortmannin; ***, $p < 0.001$ compared to wortmannin-treated control). Note that in the presence of wortmannin the response of the cells to insulin was abolished while their response to vanadate and pV was not affected.

Figure 6.3 Effect of wortmannin on PI 3-kinase activity stimulated by insulin and pV

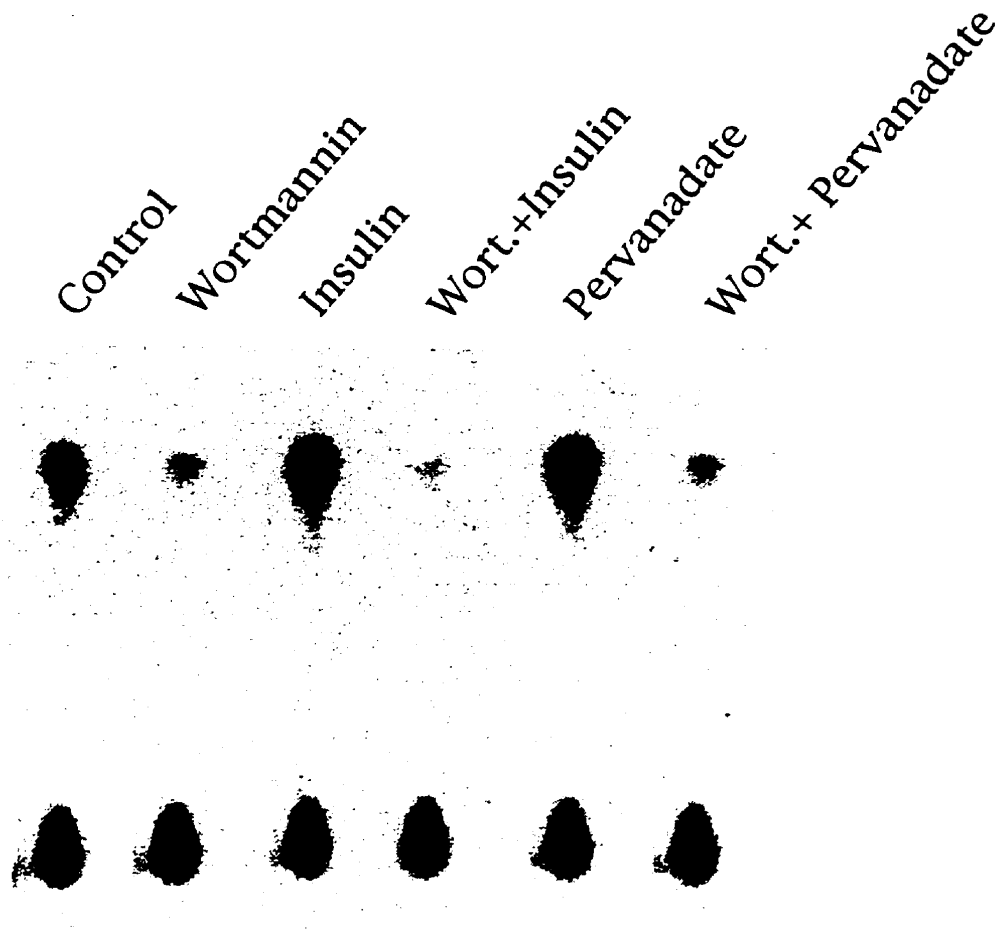

Serum deprived L6 myotubes were incubated without or with 100 nM wortmannin for 15 min followed by stimulation with insulin (100 nM, 5 min) or pV (100 μ M, 15 min). Following, immunoprecipitations were performed with antiphosphotyrosine-specific antibody and PI 3-kinase activity was measured as described in Methods. The picture is from a TLC plate of one of three experiments with similar results.

levels of PI (3,4)-P₂ and PI (3,4,5)-P₃ (Figure 6.4). Wortmannin was effective in blocking the effect of all three agents on the generation of the PI 3-kinase lipid products in intact live cells (Figure 6.4) consistent with an inhibition of the stimulation of PI3-kinase activity detected in vitro (Figure 6.3).

6.4.4. Inhibition of MEK does not block glucose transport stimulation

Insulin stimulates the activation of two major signalling pathways, the PI 3-kinase and the Ras-Raf-MEK-MAPK cascade (discussed in section 1.2.2.3). Although most studies support the concept that metabolic actions of insulin, particularly glucose uptake are mediated via the PI-3 kinase pathway as reviewed in Chapter 1, there is some evidence that the Ras pathway may contribute to stimulation of glucose uptake under certain conditions (170,171). To investigate the possibility that vanadate or pV may utilize this pathway a MAPK Kinase (MEK) inhibitor (PD 09805) was used. The myotubes were incubated with 10 μ M PD 098059 for 1 h before and during stimulation with insulin (100 nM, 30 min) vanadate (5mM, 60 min) or pV (100 μ M, 60 min). PD 098059 did not affect either basal glucose transport or the stimulation by insulin, vanadate or pV (Figure 6.5) suggesting that MAPK activation by MEK is not important in the signalling pathway of any of the agents examined.

6.4.5. Vanadate- and pV-stimulated glucose transport does not involve PKC

It has been previously reported that acute activation of protein kinase C (PKC) by phorbol myristate acetate (PMA) leads to an increase in glucose uptake (177). To determine whether the mechanism of action of vanadate and pV to increase glucose transport involves PKC, the glucose transport response of the cells to insulin, vanadate and pV was examined after downregulation of PKC or in the presence of PKC inhibitors. Acute exposure of L6 myotubes to 1 μ M PMA resulted in the stimulation of glucose transport (171 ± 2.7 % of control) to levels similar to that of insulin (182 ± 2.1 % of control) (Figure 6.6). After chronic exposure (24 h) to 100 nM PMA to downregulate PKC (293) the cells were washed and restimulated with 1 μ M

Figure 6.4 Effect of wortmannin on insulin, vanadate and pV stimulation of synthesis of lipid products

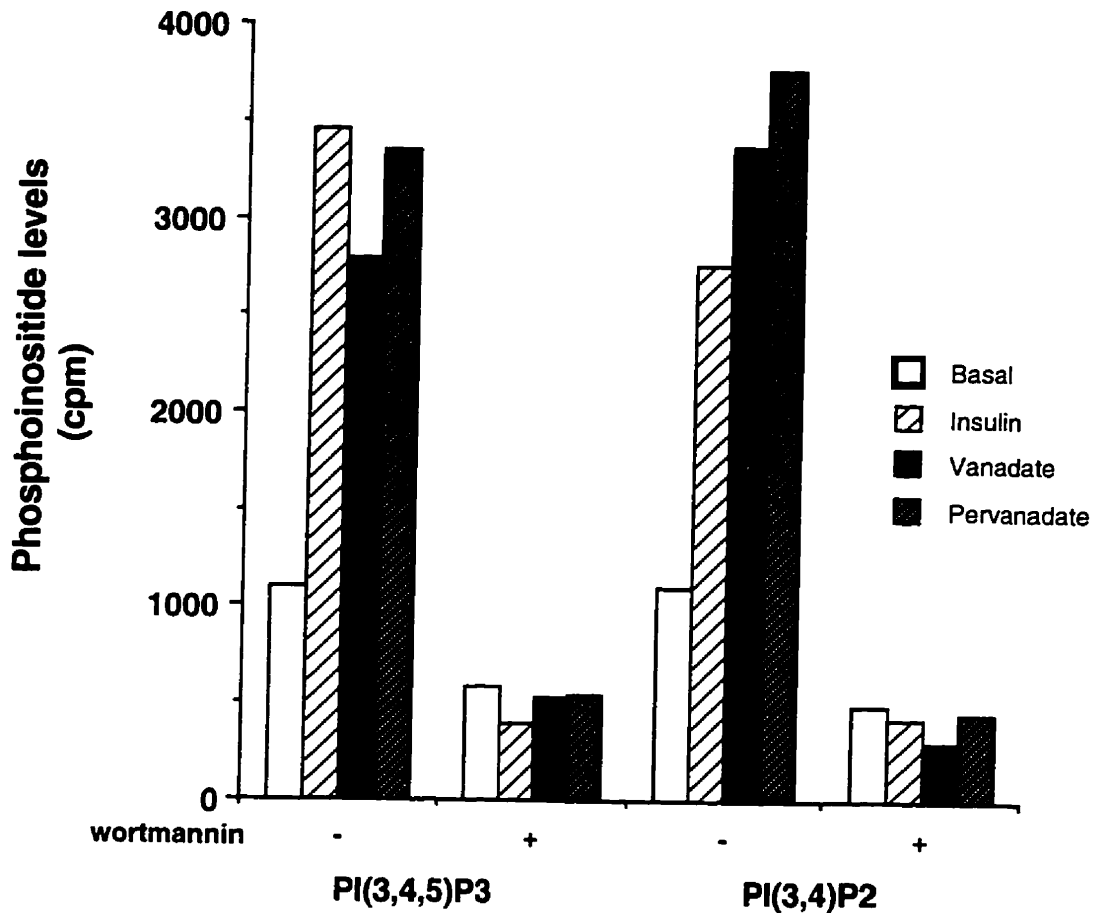

Cells were ^{32}P phospholabelled followed by incubation with (+) or without (-) wortmannin (100 nM) for 15 min and stimulation with insulin (100 nM) for 5 min, vanadate (5 mM) and pervanadate (100 μM) for 15 min. Lipids were extracted, separated and determined as described in the Methods. The results shown are from one of 3 experiments with similar results. Note that all three stimuli increased the levels of the phospholipids measured and that wortmannin prevented this increase.

Figure 6.5 The MEK inhibitor PD 098059 does not affect insulin-, vanadate- or pV-stimulated glucose transport

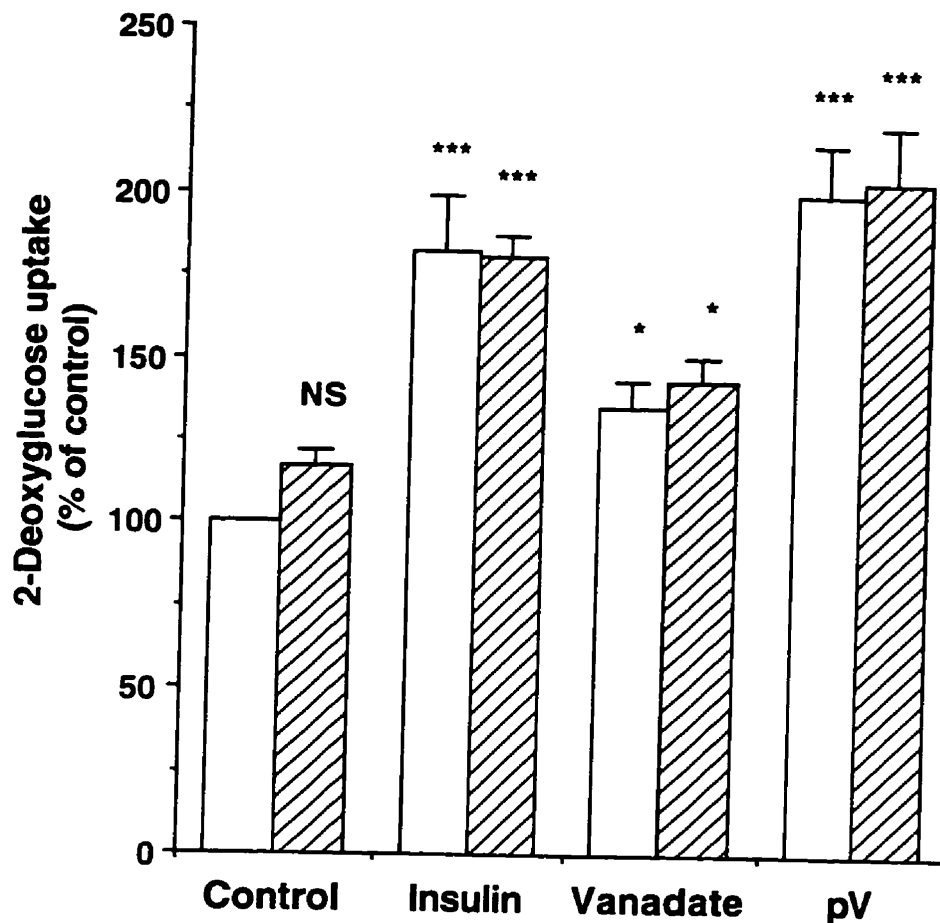

Cells were incubated without (open bars) or with (crosshatched bars) the MEK inhibitor PD 098059 (10 μ M) for 1 h before their stimulation with insulin (100 nM, 30 min) vanadate (5mM, 60 min) or pV (100 μ M, 60 min). The results are the mean \pm SE of 3 experiments performed in duplicate. (NS, nonsignificant; *, $p < 0.05$; ***, $p < 0.001$ compared to untreated control). Note that PD 098059 did not affect the response of the cells to any of the agents used.

Figure 6.6 Effect of PKC downregulation on insulin and pV action on glucose transport in myotubes

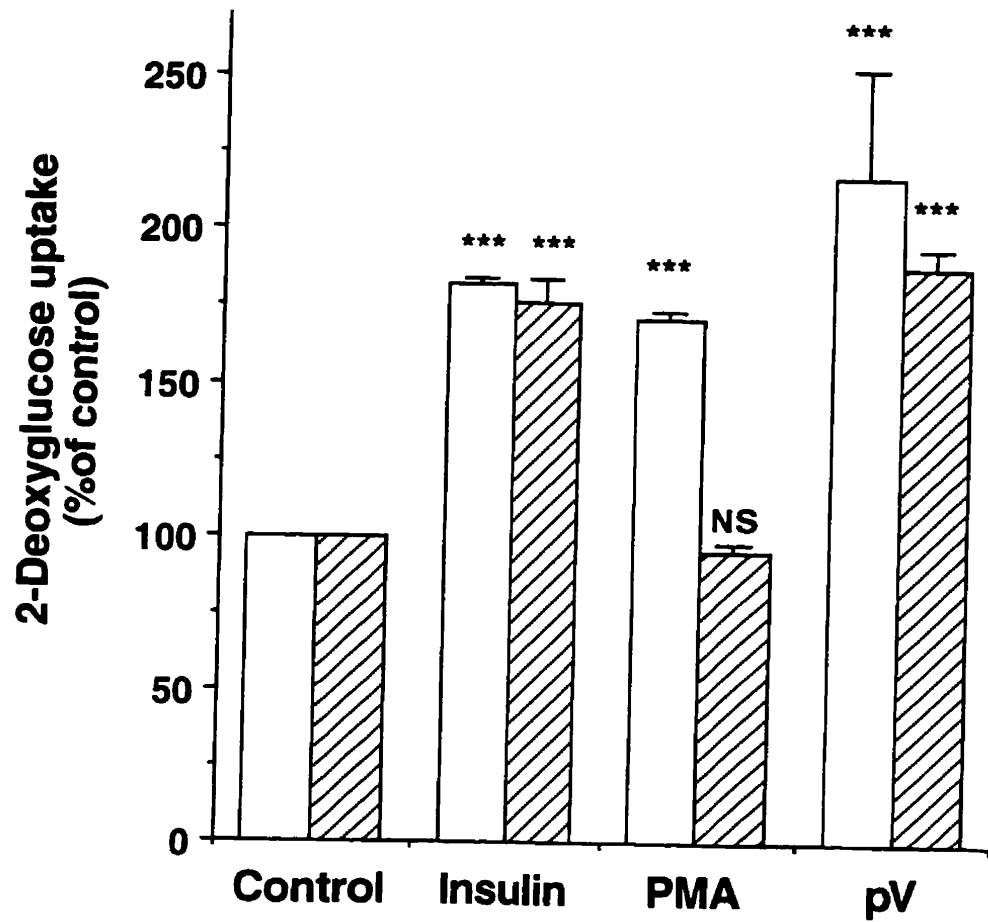

Myotubes were incubated in the absence (open bars) or the presence (crosshatched bars) of 100 nM PMA for 24 hours. At the end of this incubation the cells were washed with HBS containing 5 mM glucose and stimulated with PMA (1 μ M) or pV (100 μ M) for 60 min or with insulin for 30 min and glucose transport was measured as described in Methods. The results are the mean \pm SE of 3-4 experiments performed in duplicate. (NS, nonsignificant; ***, $p < 0.001$ compared to untreated control). Note that chronic PMA treatment abolished the acute PMA response of the cells while did not affect the response of the cells to insulin or pV.

PMA. Glucose uptake was no longer stimulated by PMA indicating that PKC activity was downregulated. In contrast, the responses of the cells to insulin as well as to pV (Figure 6.6) and vanadate (data not shown) were not significantly altered by PKC downregulation. In a second approach, L6 myotubes were preincubated with the PKC inhibitors calphostin C (0.2 μ M) for 30 min or bisindolylmaleimide (BIM) (1 μ M) for 60 min followed by stimulation with insulin, vanadate or pV for 60 min. The PKC inhibitors did not alter glucose transport stimulation by any of the agents (Table 6.1). These data suggest that PKC does not play a significant role in the insulin-, vanadate- or pervanadate-induced increase in glucose transport.

6.4.6. Cytochalasin D inhibits insulin-, vanadate- and pV-stimulated glucose transport

Cytochalasin D (CD), which disrupts the actin network has been documented to inhibit insulin-stimulated glucose transport in L6 myotubes (185). To examine whether an intact actin network is also required for glucose uptake stimulated by vanadate and pV, myotubes were preincubated for 1 h in the presence of 1 μ M CD followed by stimulation with the different agents for 1 h. CD abolished the insulin as well as the vanadate and pV stimulation of glucose uptake (Figure 6.7) suggesting that the actin network is important for the action of all these agents.

Table 6. 1 Effect of PKC inhibitors on insulin, vanadate and pV-stimulated glucose transport

Treatment of the cells without and with the PKC inhibitors Calphostin C (CC) (0.2 μ M) for 30 min or bisindolylmaleimide (BIM) (1 μ M) for 60 min was followed by addition of insulin (100 nM), vanadate (5 mM), pV (100 μ M) or PMA (100 nM) for 60 min before the glucose uptake assay. The results are the Mean \pm SE of 3 separate experiments performed in duplicate. (NS, non significant; *, $p < 0.05$; **, $p < 0.01$; ***, $p < 0.001$; ND, not determined). Note that the response of the cells to insulin, vanadate and pervanadate was not affected by any of the PKC inhibitors used while the response to acute PMA treatment was abolished.

Treatment	2-Deoxyglucose uptake (% of control)		
		+CC	+BIM
Basal	100	89.9 \pm 0.6 NS	98.1 \pm 0.6 NS
Insulin	187.8 \pm 11.2***	181.4 \pm 12.5***	182.8 \pm 10.7***
Vanadate	137.6 \pm 2.7*	154.1 \pm 3.8**	134.4 \pm 2.6*
Pervanadate	175.4 \pm 7***	173.6 \pm 6.3***	168.2 \pm 5.4***
PMA	171 \pm 2.7***	ND	103.7 \pm 1.8 NS

Figure 6.7 Cytochalasin D inhibits insulin-, vanadate- and pV-stimulated glucose transport

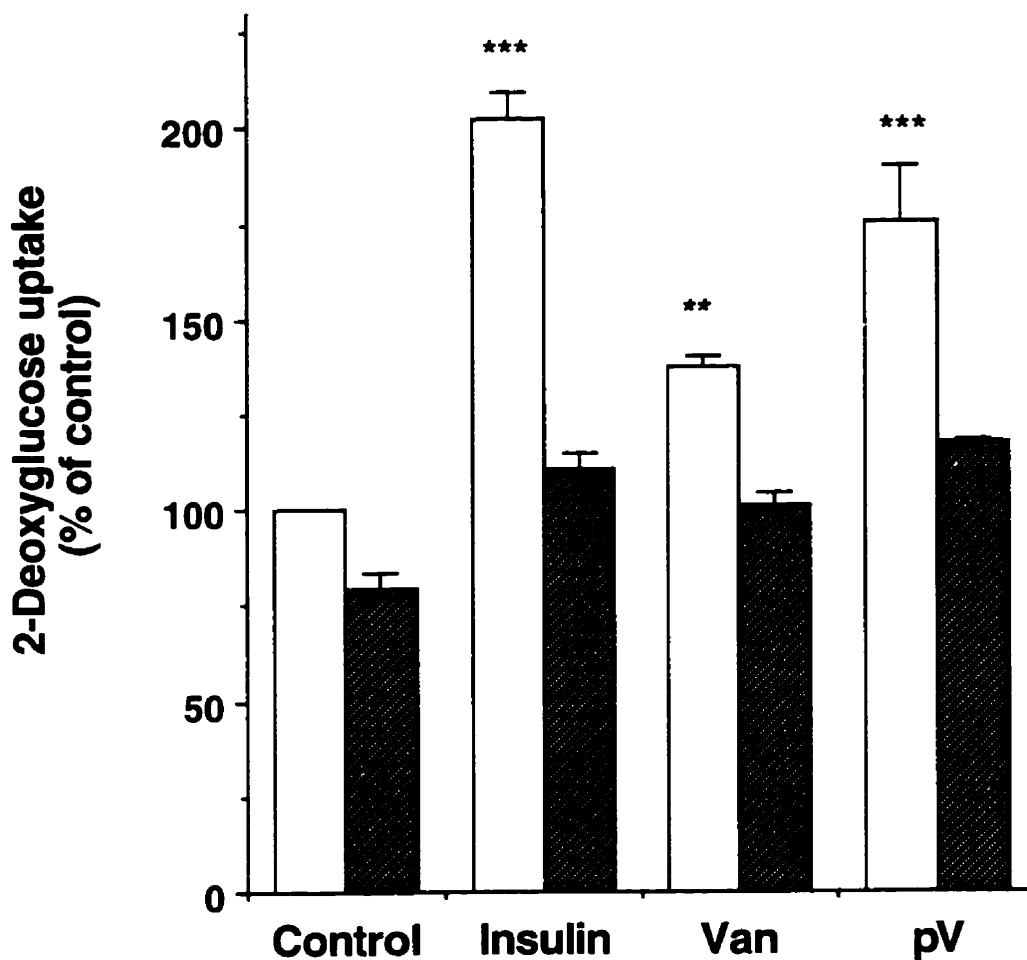

Myotubes were incubated in the absence (open bars) or the presence (crosshatched bars) of 1 μ M Cytochalasin D (CD) for 1 hour before they were stimulated with insulin (100 nM), vanadate (5mM) or pV (100 μ M) for 60 min. The results are the mean \pm SE of 3 experiments performed in duplicate. (NS, non significant; **, $p < 0.01$; ***, $p < 0.001$ compared to untreated control). Note that CD treatment abolished the response of the cells to all stimuli used.

6.5. DISCUSSION

It was shown in the study presented in Chapter 5 and it is confirmed here that vanadate and pV mimic insulin to stimulate glucose transport in cultured L6 skeletal muscle cells. The biochemical mechanism of this action was investigated in this chapter based on current knowledge of insulin signalling mechanisms as well as other known stimuli of glucose transport. A critical component of glucose transport stimulation by insulin immediately downstream of the insulin receptor and its substrate IRS-1 is the enzyme PI 3-kinase (see 1.2.2.4). Prior to these investigations, a study by Hadari et al (484). demonstrated that *in vivo* portal vein injection of pV activated PI 3-kinase in antiphosphotyrosine and anti- IRS-1 immunoprecipitates from liver homogenates. However, there was no correlation of this activation with any insulin-like bioeffect. The data of the present study demonstrate that vanadate and pV both activate PI 3-kinase in L6 myotubes. However, in contrast to insulin, inhibition of this enzymatic activity with wortmannin did not abrogate the stimulation of glucose transport. This failure of action of wortmannin could not be attributed to lack of inhibition of PI 3-kinase activity since this activity in antiphosphotyrosine immunoprecipitates was similarly inhibited after insulin, vanadate and pV stimulation. Furthermore, the incorporation of ³²P in intact cells into the PI 3-kinase lipid products, PI(3,4,5)P₃ and PI(3,4) P₂ was also similarly inhibited after stimulation by all of these agents. The data strongly suggest that PI 3-kinase is not required for the stimulation of glucose transport by the insulin-mimetic agents vanadate and pV.

In an attempt to define the mechanism of signalling by vanadate and pV, the potential role of the family of PKC isoenzymes was examined. The diacylglycerol analog, PMA (phorbol myristate acetate) activates PKC and stimulates glucose uptake in both insulin target tissues fat and muscle (177,180,181). Furthermore, although phospholipase C (PLC) which can cleave phosphatidylinositol 4,5 bisphosphate (PIP₂) into IP₃ and DAG may not be activated by insulin, PLC γ is activated by tyrosine phosphorylation of other growth factor receptors, e.g. PDGF and EGF. Thus, since PTP inhibition by vanadate and pV is not specific, it is conceivable that tyrosine phosphorylation of other receptors or even nonreceptor tyrosine kinases (446) may

result in the generation of DAG and activation of PKC. The data show that depletion of PKC by chronic preincubation with a high concentration of PMA as well as inhibition of PKCs by two different pharmacological agents failed to block vanadate and pV stimulated glucose transport. At the same time PMA stimulation was completely abrogated. Thus, it appears that PKC is not the alternate signalling mechanism of the PTP inhibitors for stimulation of glucose transport.

Some studies suggest that MAPK does not play an important role in insulin-stimulated glucose transport (174) while others showed that activation of the Ras-MAPK pathway may lead to stimulation of glucose transport (171). Thus, it is possible that vanadium compounds may activate the Ras-MAPK pathway to increase glucose transport. The inability of the MEK inhibitor PD 098059 to block the vanadate- and pV-stimulation of glucose transport suggested that signalling events acting upstream and including MEK are probably not involved in the mechanism of action of these agents. However, in preliminary experiments it was found that while blocking MAPK tyrosine phosphorylation after insulin stimulation, the MEK inhibitor does not completely inhibit vanadate and pV stimulation of MAPK tyrosine phosphorylation (data not shown). This suggests that vanadate and pV may activate MAPK at least in part via inhibition of a MAPK specific phosphatase. Thus although MAPK activation by insulin has not been associated with glucose transport stimulation further studies are required to definitively exclude a contribution by MAPK to glucose transport stimulation by these agents

Recent studies suggest that the actin network is involved in the process of glucose transporter recruitment to the plasma membrane (185) which is the mechanism of acute stimulation of glucose transport by both insulin (136,138) and vanadate (452). The hypothesis that glucose transporter movement may rely on relatively close, if not direct, interaction between actin filaments and the GLUTs also suggests that the site of this interaction is downstream of PI 3-kinase. Indeed, it was shown that the actin-binding protein spectrin is localized on the GLUT4 glucose transporter vesicle (185). The results presented here support this concept. Disruption of the actin network by cytochalasin D (CD) blocked glucose transport stimulation by insulin as well as by vanadate and pV.

A previous study showed that wortmannin partially inhibited (by 60%) vanadate-stimulated glucose transport in L6 cells (485). However, in that study the effect of wortmannin on basal glucose transport was not measured or considered. This would result in an overestimation of the extent of inhibition. The inhibition of basal glucose transport by wortmannin has been documented (65). While this study was underway another report appeared which, similar to the data presented here, found that in 3T3-L1 adipocytes wortmannin did not inhibit pV stimulated glucose transport while PI 3-kinase activation was blocked (486). Interestingly, a nonspecific inhibitor of tyrosine kinases combined with wortmannin did block the pV stimulated glucose transport. Taken together these data suggest that pV stimulates glucose transport by a tyrosine kinase dependent mechanism which is independent of PI 3-kinase activity. The fact that insulin stimulation of glucose transport requires PI 3-kinase activity, strongly suggests that the putative tyrosine kinase is not the insulin receptor.

Shisheva and Shechter have previously demonstrated the activation of a 54 kDa cytosolic tyrosine kinase (cyt PTK) in rat adipocytes by vanadate (446). Selective inhibition of this cyt PTK by staurosporine, resulted in inhibition of several biological effects but these did not include glucose transport (446). Thus, the tyrosine kinase involved in glucose transport stimulation by vanadate and pV remains to be identified.

6.4. CONCLUSIONS

In conclusion, the data presented in this chapter show that a signal transduction mechanism exists by which vanadate and pV can activate the molecules involved in glucose transport stimulation downstream of PI 3-kinase. Since these signalling steps leading to the stimulation of glucose transport remain to be identified, future studies may be designed utilizing vanadate and pV as probes to investigate this mechanism. Furthermore, the definition of such a "bypass" pathway is extremely important for our understanding of glucose transport regulation in disease states. The design of novel therapies to activate such a pathway in the face of insulin resistance such as in type II diabetes mellitus, should be a worthwhile goal.

CHAPTER 7
OVERALL DISCUSSION

Diabetes is a disease that affects about 5% of the North American population and about 80% of the people affected have Type II or non-insulin-dependent diabetes (NIDDM). Type II diabetes is a multifactorial disease characterized by both insulin resistance as well as insulin deficiency. Defects may occur at multiple steps of the insulin signalling pathway such as at the insulin receptor, IRS-1, PI 3-kinase or the glucose transporters. It is clearly important to identify the defects, understand their cause and develop therapies that have the capacity to act at multiple levels and correct the abnormalities. Sulfonylurea drugs have been used for many years to treat type II diabetes and more recently the protein tyrosine phosphatase inhibitors vanadate and pervanadate have been shown to have insulin-like effects to lower blood glucose levels. The goal of the studies presented here was to understand the mechanism by which these agents exert their hypoglycemic effects and to determine any other effects that these agents may exert which may not improve or even oppose metabolic homeostasis.

Skeletal muscle is quantitatively the major insulin-sensitive tissue in the body and therefore a very important determinant of fuel metabolism. For this reason the studies included in this thesis were performed entirely with muscle cells in culture which resemble skeletal muscle in many ways and provide a valuable tool to investigate the mechanisms of insulin action as well as the action of other hormonal stimuli and pharmacological agents.

The specific objectives of the studies presented here were to examine the effects of the sulfonylurea drugs and vanadium compounds on muscle cells and investigate their mechanisms of action.

Regulation of glucose transport and glucose transporters by the sulfonylureas gliclazide and glyburide.

Although many studies have suggested that sulfonylureas have direct extra-pancreatic actions, this issue is still controversial. Furthermore, new sulfonylurea compounds used to treat diabetes patients may have different or modified properties compared to the existing agents. In the work presented in Chapter 3, the action of gliclazide, a new sulfonylurea, was examined and

compared to that of glyburide. It was found that both agents increased glucose uptake into L6 cells to levels similar to those observed with acute insulin stimulation. However, gliclazide and glyburide required longer (chronic) incubation times (compared with insulin) in order to observe an effect. Sulfonylurea action to increase glucose uptake in L6 cells was independent of insulin and was not blocked by the protein synthesis inhibitor cycloheximide suggesting that new protein synthesis is not required. Examination of the distribution of glucose transporters revealed that total GLUT1 glucose transporter content as well as plasma membrane (PM) levels of the GLUT1 glucose transporter were increased. The total content and plasma membrane levels of the GLUT3 and GLUT4 glucose transporters did not increase significantly. Furthermore, the internal membrane glucose transporter levels were not changed suggesting that the stimulation of glucose uptake by gliclazide and glyburide is not associated with a redistribution but rather an increase in total membrane content and PM level of GLUT1 which was independent of protein synthesis. These data suggest a novel action of sulfonylureas to stabilize the GLUT1 protein at the plasma membrane. The stabilization of transporters would indicate an inhibition of GLUT1 degradation. As discussed in section 3.5, other possibilities such as a decrease of GLUT1 internalization or an increase in its recycling may also play a role in elevation of GLUT1 levels observed with sulfonylureas. Several experimental approaches can be used in the future to distinguish between these possibilities. The possibility that there is an inhibition of GLUT1 degradation by sulfonylureas could be directly tested by labeling studies. Pulse-chase experiments using ^{35}S -methionine could be performed in which the cells are incubated first with ^{35}S -methionine allowing enough time for the radioactivity to be incorporated into proteins and then chasing with non-radioactive methionine and examining the rate of the disappearance of radioactivity. This corresponds to the rate of the turnover of proteins. Specific anti-GLUT1 antibodies could be used for immunoprecipitations to examine the turnover rate of this transporter. It is interesting that the increase in GLUT1 was observed in the PM but not in IM fraction. It is not known whether GLUT1 may enter a degradative compartment directly from the PM (pathway 1a in Figure 7.1). Thus inhibition of GLUT1 degradation may suggest an action of sulfonylureas at sites 1a, 1b or 2 in Figure 7.1. It is possible that GLUT1 enters the IM

Figure 7.1 Possible sites of action of sulfonylureas in L6 muscle cells to effect GLUT1 stabilization at the plasma membrane.

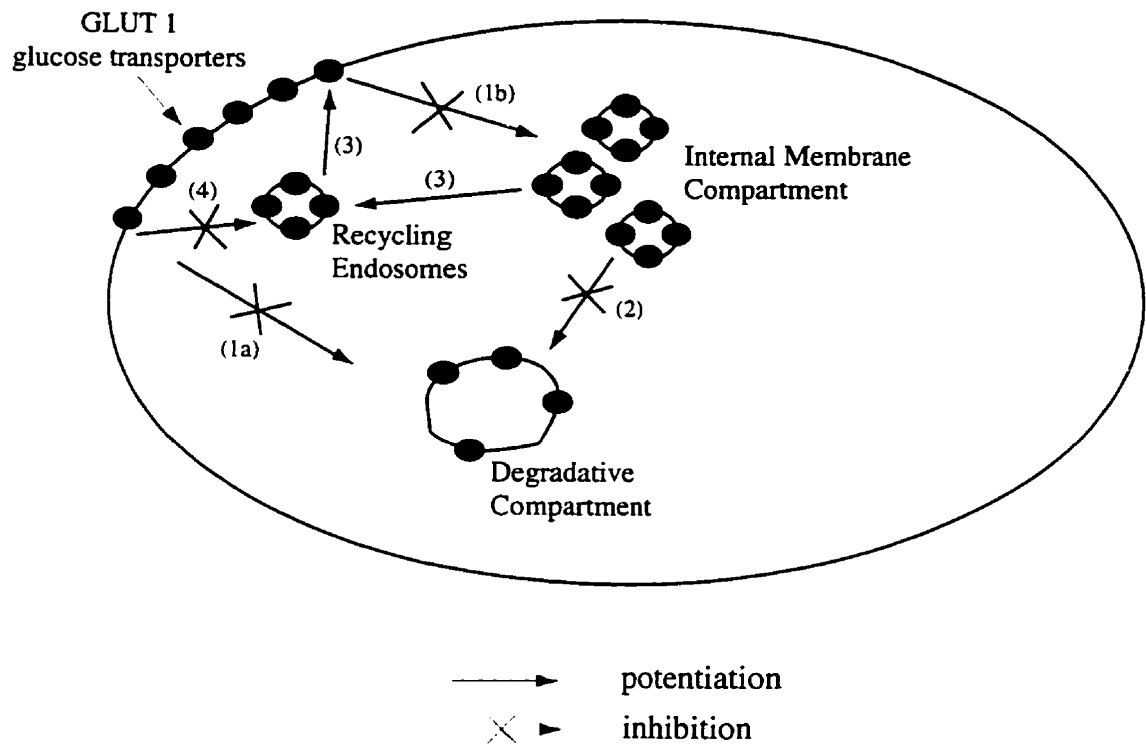

The different sites of action of sulfonylureas to increase plasma membrane GLUT1 levels are shown here and discussed in detail in the text.

compartment first via pathway 1b and from there is targeted to either a degradative (pathway 2) or recycling compartment (pathway 3). Since sulfonylurea treatment did not affect IM GLUT1 content an inhibition of degradation would be associated in this circumstance with a compensatory increase in recycling of the additional GLUT1 to the PM (pathway 3, Figure 7.1). An inhibition of GLUT1 internalization (pathway 4, Figure 7.1) is also possible. This rapid recycling pathway may not be associated with inhibition of degradation. Measuring the rate of endocytosis would answer the question of whether inhibition of internalization takes place. Such measurements could be achieved using specific photoaffinity reagents that only label plasma membrane glucose transporters. Membrane fractionation and immunoprecipitation with specific GLUT1 antibody should be performed to measure the disappearance of labeled GLUT1 from the plasma membrane. To investigate the possibility that an increase in recycling of GLUT1 takes place with sulfonylureas, labeling of plasma membrane GLUT1 should be done. The cells are then incubated for 60-120 min to allow internalization of the labeled transporters. This is followed by trypsinization which removes cell surface proteins including the labeled GLUT1. The cells are then reincubated to allow labeled GLUT1 from the internal membranes to reappear on the PM, which can be quantified by cell fractionation and immunoprecipitation of GLUT1. The time course of reappearance can be compared in the presence and absence of sulfonylureas.

It has been previously reported that chronic insulin treatment of L6 cells results in a similar increase in basal glucose transport which is also associated with an increase in GLUT1 levels. However, the insulin effect is dependent on protein synthesis (334). Although all these studies were performed in cultured cells, it is possible that similar events may take place *in vivo*. Chronic insulin and sulfonylurea treatment in NIDDM may therefore result in similar effects on blood glucose levels, that is a reduction and correction of hyperglycemia mediated in part by an increase in GLUT1 levels by distinct mechanisms. It should be noted that the end result, the improvement of glucose uptake in muscle would result in the amelioration of the hyperglycemia in NIDDM. The mechanism by which sulfonylureas stabilize GLUT1 is not known. It is not clear whether the recently cloned sulfonylurea receptor is expressed in L6 cells. In preliminary experiments cromakalim, an activator of ATP-sensitive K⁺ channels did not block these effects

of gliclazide and glyburide suggesting another mechanism of sulfonylurea action. Some studies have suggested that sulfonylureas may act on peripheral tissues by activation of PKC (293,295,299). However, (in preliminary experiments) the sulfonylurea effect on glucose uptake could not be abolished by pharmacological inhibitors of PKC such as staurosporine and H7. Thus the data suggest that an additional mechanism of sulfonylurea action remains to be discovered. Clearly, there is further work to be done in this area. Nevertheless, the studies presented here support the concept that there is a direct peripheral (extrapancreatic) action of sulfonylureas. It has been exceedingly difficult to address this issue in vivo because of the multiple hormonal and metabolic changes caused by sulfonylureas. Moreover, the lack of peripheral effects in Type I diabetes does not necessarily indicate an absence of effect in Type II, since the latter is characterized by a unique pathophysiology associated with insulin resistance. A better understanding of the mechanism of action of these agents will contribute to the development of new and better therapies for NIDDM.

Effects of vanadate and pervanadate in muscle cells that are not similar to those of insulin.

Vanadium compounds have been extremely useful as probes of enzyme structure and function and of the role of tyrosine phosphorylation in cellular signalling. The ability of these agents to mimic insulin and enhance its metabolic actions in vitro and in vivo with relatively few adverse effects has sparked interest in their potential as pharmacological agents.

The work presented in Chapter 5 shows that the protein tyrosine phosphatase inhibitors vanadate and peroxide of vanadate (pV), similar to insulin, stimulated glucose transport. However, while insulin stimulated MeAIB (a nonmetabolizable analog of system A amino acid transport) uptake vanadate and pV inhibited basal and insulin-stimulated MeAIB uptake. Furthermore, vanadate completely blocked insulin-stimulated MeAIB uptake in rat hepatoma cells. Kinetic analysis revealed that the inhibitory effect on basal MeAIB uptake was associated with an increase in K_m and a small decrease in V_{max} while the insulin-stimulated increase in V_{max} was completely inhibited. Ouabain, an inhibitor of Na^+/K^+ ATPase, did not inhibit

MeAIB uptake and the inhibition by vanadate and pV was not blocked by cycloheximide. Amino acid deprivation resulted in stimulation of MeAIB uptake which was also inhibited by vanadate.

These results suggest that the vanadium compounds may have different actions on basal versus insulin-stimulated amino acid uptake. Thus the difference in sensitivity of basal and insulin-stimulated MeAIB uptake to the vanadium compounds and the different kinetic parameters associated with inhibition suggest that two different mechanisms may be responsible. It is not possible from the data generated in this study to determine the precise mechanism, however the relative potency of vanadate compared with pervanadate, the lack of requirement of protein synthesis or inhibition of Na^+/K^+ ATPase are all consistent with PTP inhibition. The inhibition of PTPs is a prominent cellular effect of both vanadate and pV and accounts for their insulin-mimetic actions. Similarly, other biological effects of these agents unrelated to insulin and even opposite to those of insulin may be mediated by a similar mechanism, e.i. inhibition of PTPs. The lack of specificity of the compounds as PTP inhibitors and the large number of PTPs which are involved in different cellular processes make this a likely possibility. Also different PTPs may have different sensitivities to inhibition by vanadium compounds and therefore the dose-response of a certain bioeffect measured will depend on the particular PTPs involved. This difference in sensitivity of the different PTPs may explain why pervanadate at concentrations ($10\ \mu\text{M}$) that stimulated glucose transport did not inhibit amino acid transport. Using these compounds as probes one cannot be more precise as to the specific PTP involved. Thus, further work is required to investigate directly the role of a PTP in mediating these actions. An example of such a research direction could be to investigate the SH2 domain-containing PTP SHP2/SYP which has been demonstrated to bind to tyrosine phosphorylated IRS-1 and to be activated upon insulin signalling (397,398). Several studies suggest that SHP2 is required for the mitogenic action of insulin (398) but no studies to date have investigated its role in amino acid uptake or protein metabolism. It is of interest that preliminary experiments showed that vanadate and pervanadate also inhibit insulin's mitogenic action. Insulin- and FBS-stimulated cell proliferation, assessed by thymidine incorporation, were all inhibited by vanadate in L6 myoblasts (data not shown). Therefore, apart from amino acid transport thymidine incorporation

is also inhibited by vanadate. This is the first observation of an agent that mimics the metabolic effect of insulin on glucose transport and inhibits its mitogenic effects. Whether this is related to an inhibition of SHP2 or another phosphatase remains to be determined.

In terms of their potential as therapeutic agents for diabetes clearly these compounds need to be fully evaluated. In this regard the finding that some biological effects of insulin may be inhibited is important and further in vivo studies will be required to determine whether this is clinically significant.

Mechanism of action of vanadate and pervanadate to increase glucose transport in muscle cells.

Although both vanadate and pV stimulate glucose uptake into L6 myotubes to an extent similar to that of insulin their mechanism of signal transduction is not clearly defined. In the study presented in Chapter 6 the role of PI 3-kinase, a mediator of insulin-stimulated glucose transport, in the stimulation of glucose uptake by vanadate and pV was examined. Inhibition of PI 3-kinase with wortmannin blocked insulin stimulation of glucose uptake but not that stimulated by vanadate or pV. Stimulation of PI3-kinase, detected in anti-phosphotyrosine immunoprecipitates, was blocked by wortmannin after all three stimuli. Furthermore, wortmannin blocked the in vivo increase of the PI 3-kinase lipid products PI(3,4,5)P3 and PI(3,4)P2, in response to insulin, vanadate and pV. Taken together, the data suggest that vanadate and pV increase glucose uptake in muscle cells by a mechanism that is independent of PI 3-kinase or that these agents act at a step downstream of PI 3-kinase (Figure 7.2). Additionally, it is shown in Chapter 6 that PKC downregulation by chronic incubation of the cells with PMA, as well as inhibition of PKCs by two different pharmacologic agents did not block the action of vanadate and pV on glucose transport. Therefore, PKC appears not to be involved in the mechanism of action of these agents.

In the search for targets of action of vanadate and pV novel signalling molecules and pathways have to be considered. Recently, a serine/threonine kinase has been identified known

Figure 7.2 Stimulation of glucose transport by vanadium compounds

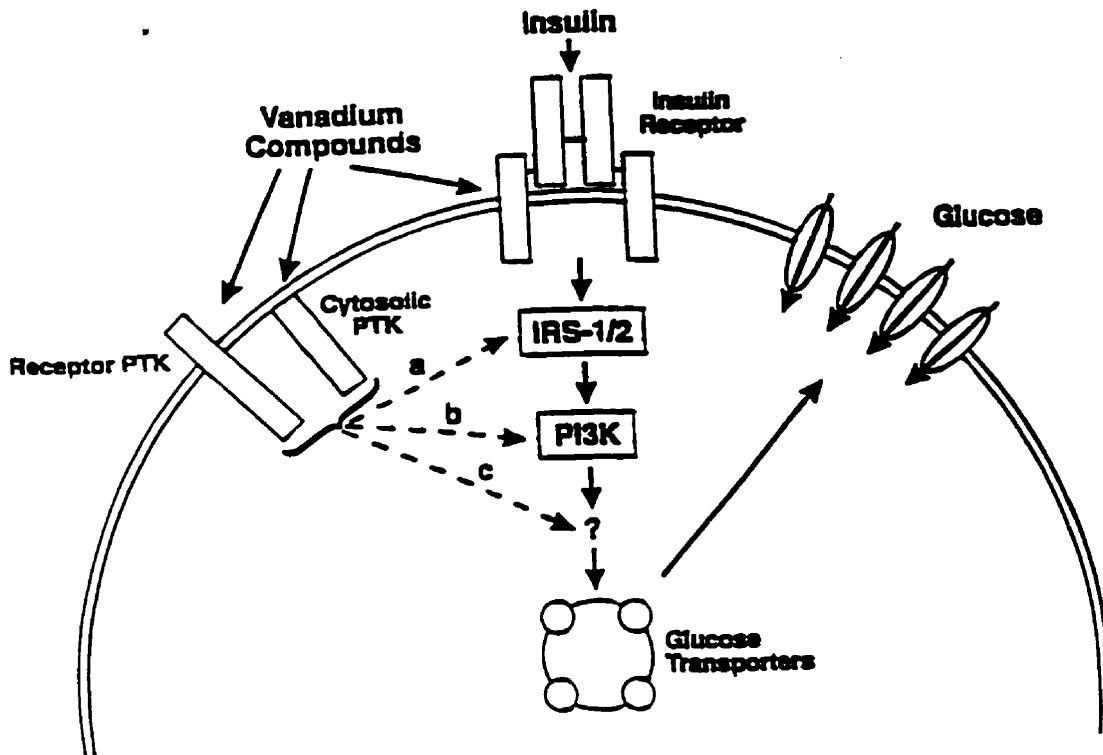

Insulin stimulation of glucose transport is mediated via tyrosine phosphorylation of IRS 1 and/or IRS-2 and subsequent activation of PI 3-kinase. The events linking PI 3-kinase to insulin sensitive glucose transporter vesicle translocation to the plasma membrane remain to be defined. It is proposed that vanadate may stimulate glucose transport via alternate pathways which appear to require tyrosine phosphorylation but not necessarily that of the IR or IRS-1. In addition glucose transport stimulation may occur, at least in part, by mechanisms which do not involve PI 3-kinase. The molecular components of the "bypass" pathways a,b, and c remain to be defined. Insulin resistance caused by defects at sites proximal to the point of convergence (?) may be overcome by vanadium compounds and novel drugs may be designed to stimulate these pathways.

as Akt/Rac/PKB which appears to be activated by insulin through ser/thr phosphorylation (77). The insulin stimulation of Akt activity is inhibited by PI 3-kinase inhibitors (wortmannin and LY294002) or by overexpression of a mutant p85 subunit of PI 3 kinase indicating that this protein kinase is downstream of PI 3-kinase (76-78). A potential mechanism of action of vanadium compounds could be the activation of Akt by a mechanism bypassing PI-3 kinase. Although currently there is no available evidence suggesting a role of Akt in the mechanism of regulation of glucose transport, it is possible that Akt may be involved in this event. Therefore, it would be interesting to investigate the action of vanadium compounds under conditions where Akt activity could be abolished, such as overexpression of dominant negative Akt or Akt antisense.

The role of the Ras-MAPK pathway in mediating the effects of vanadium compounds on glucose transport needs to be further investigated. As shown in chapter 6 the MEK inhibitor did not block stimulation of glucose transport by vanadate and pV. It should be noted that the inhibition is specific for MKK1 (MAPK kinase 1) but only inhibit MKK2 at higher concentration and does not inhibit the other MKKs (Park Davis, product information). As discussed in Chapter 6, vanadate and pV may stimulate MAPK activation via inhibition of a MAPK specific phosphatase. MKP-1 is a dual specificity phosphatase, which is sensitive to vanadate, and was initially thought to specifically dephosphorylate MAPK (see 4.8.4.2). However, a novel dual-specificity phosphatase Pyst 1, has higher specificity for MAPK than MKP-1 (487). It is therefore possible that vanadate and pV exert a stimulatory effect on glucose transport via stimulation of MAPK mediated by the inhibition of such a phosphatase. Thus, the studies presented here do not rule out a contribution by MAPK to vanadium compound mediated glucose transport. One way of investigating this possibility would be to use antisense strategy to knock out MAPK and then examine the effects of vanadate and pV.

The MAPK family has been expanded recently with new isoforms which include the stress activated protein kinases (SAPKs), also known as c-Jun N-terminal kinases (JNKs), and the p38/HOG1 MAPK (488,489) that are activated in cells in response to cytokines and stress stimuli such as UV irradiation and hyperosmotic shock. A novel stress- and mitogen-activated

signalling pathway is currently being elucidated which appears to lead to SAPK/JNK and p38 MAPK activation through the activation of the small GTP binding proteins of the Ras family, Rac and Cdc42. It has been suggested that Ras stands upstream of Rac and Cdc42 in the growth factor activated signalling pathways (191,490). In the GTP bound form Rac and Cdc42 activate a family of serine/threonine kinases known as p21-activated kinases (PAKs) which lead to the activation of SAPK/JNK or p38 MAPK (489,491,492) via specific MKKs (or SEKs). Specifically, it has been shown very recently that insulin activates a 65 kDa PAK isoform in L6 myotubes in a PI 3-kinase sensitive manner (493). Moreover, the hormone has been shown to induce JNK and p38 MAPK activation in Rat 1 fibroblasts overexpressing insulin receptors (490) and phosphorylation in L6 myotubes (493), respectively. Although the exact role of JNK and p38 MAPK in the insulin signalling cascade and insulin action is presently not clear, it is possible that these enzymes may participate in vanadate and pV signalling. Future studies should address the role of stress-activated kinases in the vanadate-induced metabolic and mitogenic actions.

Previous studies (185) and the data presented in Chapter 6 show that the cellular actin network is involved in both the insulin and the vanadate and pV stimulation of glucose transport. It is possible that the actin network is the point of convergence of various signalling pathways activated by different stimuli leading to glucose transporter recruitment to the plasma membrane. Presently, it is not clear whether the actin network facilitates a signalling or a membrane traffic event in the regulation of glucose transport. Furthermore, it would be interesting to examine in the future the role of other cytoskeletal elements such as the tubulin network of the cells and/of other cytoskeletal proteins in the vanadate- and pV-mediated effects.

One question raised from these studies is whether the insulin receptor kinase is involved in the mechanism of action of vanadate and pV. While there is evidence suggesting that pV acts through the insulin receptor (382) this is not clear for vanadate. Also it is not known whether the immediate substrates of the insulin receptor, such as IRS-1/IRS-2 are involved in the mechanism of action of vanadate and pV. Therefore, future studies should address these questions carefully and specifically by using cells lacking insulin receptor and/or IRS molecules. Also the

involvement of tyrosine kinases other than the insulin receptor should be investigated. Although a 54 kDa cytosolic tyrosine kinase has been shown to be involved in the vanadate induced lipogenic response of adipocytes, it does not appear to mediate vanadate stimulated glucose transport.

It is interesting that vanadate and pervanadate can correct the hyperglycemia observed in NIDDM and this may be achieved by a mechanism that can “bypass” certain steps which are key elements in insulin signalling (Figure 7.2). Defects in NIDDM may occur at these or other upstream steps and therefore having agents that can bypass these defects provides a solution to optimize metabolic control.

An increased understanding of the molecular mechanisms by which vanadate exerts its actions is required. This will not only better define the potential use of these agents for particular patients but also elucidate novel signalling pathways to metabolic functions. Physiological studies of vanadate effects on protein metabolism, an important component of insulin action, are lacking. Additional studies are also needed to document the putative inhibitory effects on cell growth and proliferation in vivo. Compared with insulin and IGF-1, vanadate could present an augmented ratio of metabolic to mitogenic stimulation. At this point the utility of these agents appears to be most promising for insulin resistant subjects with forms of Type II diabetes.

REFERENCES

1. **Steiner, D. F., Hallund, O., Rubenstein, A., Cho, S., and Bayliss, C.** (1968) Isolation and properties of proinsulin, intermediate forms and other minor components from crystalline bovine insulin. *Diabetes* 17, 725-736
2. **Cheatham, B., and Kahn, C. R.** (1995) Insulin action and the insulin signaling network. *Endo. Rev.* 16, 117-142
3. **Eisenbarth, G.** (1986) Type I diabetes: a chronic autoimmune disease. *N. Engl. J. Med.* 314, 1360-1368
4. **Kahn, C. R.** (1994) Banting Lecture: Insulin action, diabetogenesis, and the cause of Type II diabetes. *Diabetes* 43, 1066-1084
5. **Kasuga, M., Karlsson, F. A., and Kahn, C. R.** (1982) Insulin stimulates the phosphorylation of the 95,000-dalton subunit of its own receptor. *Science* 215, 185-187
6. **Olson, T. S., Bamberger, M. J., and Lane, M. D.** (1988) Post-translational changes in tertiary and quaternary structure of the insulin proreceptor: correlation with acquisition of function. *J. Biol. Chem.* 263, 7342-7351
7. **Roth, R. A., and Cassel, M. P.** (1983) Insulin receptor: evidence that it is a protein kinase. *Science* 219, 299-301
8. **Perlman, R., Bottaro, D., White, M. F., and Kahn, C. R.** (1989) Conformational changes in the α - and β -subunits of the insulin receptor identified by anti-peptide antibodies. *J. Biol. Chem.* 264, 8946-8950
9. **Myers, M., and White, M.** (1993) The new elements of insulin signaling. Insulin receptor substrate-1 and proteins with SH2 domains. *Diabetes* 42, 643-650
10. **White, M. F., Maron, R., and Kahn, C. R.** (1985) Insulin rapidly stimulates tyrosine phosphorylation of a Mr 185,000 protein in intact cells. *Nature* 318, 183-186
11. **Rosen, O. M.** (1987) After insulin binds. *Science* 237, 1452-1458
12. **Ullrich, A., Bell, J. R., Chen, E. Y., Herrera, r., Petruzzelli, L. M., Dull, T. J., Gray, A., Coussens, L., Liao, Y.-L., Tsubokawa, M., Mason, A., Seeburg, P. H., Grunfeld, C., Rosen, O. M., and Ramachandran, J.** (1985) Human insulin receptor and its relationship to the tyrosine kinase family of oncogenes. *Nature* 313, 756-761
13. **Rosen, O. M., Herrera, R., Olowe, Y., Petruzzelli, L. M., and Cobb, M. H.** (1983) Phosphorylation activates the insulin receptor protein kinase. *Proc. Natl. Acad. Sci. U.S.A.* 80, 3237-3240
14. **Takayama, S., White, M., Iuris, V., and Kahn, C.** (1980) Phorbol esters modulate insulin receptor phosphorylation and insulin action in cultured hepatoma cells. *Proc Natl Acad Sci USA* 81, 7797-7801
15. **Ellis, L., Clauser, E., Morgan, D. O., Edery, M., Roth, R. A., and Rutter, W. J.** (1986) Replacement of insulin receptor tyrosine residues 1162 and 1163 compromises insulin-stimulated kinase activity and 2-deoxyglucose uptake. *Cell* 45, 721-732
16. **McClain, D. A., Maegawa, H., Lee, J., Dull, T. J., Ullrich, A., and Olefsky, J. M.** (1987) A mutant insulin receptor with defective tyrosine kinase displays no biological activity and does not undergo endocytosis. *J. Biol. Chem.* 262, 16663-16671
17. **Chou, C. K., Dull, T. J., Russell, D. S., Gherzi, R., Lebwohl, D., and Ullrich, A.** (1987) Human insulin receptors at the ATP-binding site lack protein

- tyrosine kinase activity and fail to mediate postreceptor effects of insulin. *J. Biol. Chem.* 262, 1842-1847
18. **Ebina, Y., Araki, E., Taira, M., Shimada, F., Mori, M., Craik, C., Siddle, K., Pierce, S., Roth, R., and Rutter, W.** (1987) Replacement of lysine residue 1030 in the putative ATP-binding region of the insulin receptor abolishes insulin- and antibody-stimulated glucose uptake and receptor kinase activity. *Proc Natl Acad Sci* 84(704-708)
 19. **Friedenberg, G. R., Henry, R. R., Klein, H. H., Reichart, D. R., and Olefsky, J. M.** (1987) Decreased kinase activity of insulin receptors from adipocytes of non-insulin-dependent diabetic subjects. *J. Clin. Invest.* 79, 240-250
 20. **Caro, J. F., Sinha, M. K., Raju, S. M., Ittoop, O., Pories, W. J., Flickinger, E. G., Meelheim, D., and Dohm, G. L.** (1987) Insulin receptor kinase in human skeletal muscle from obese subjects with and without non-insulin-dependent diabetes. *J. Clin. Invest.* 79, 1330-1337
 21. **Maegawa, H., McClain, D. A., Freidneberg, G., Olefsky, J. M., Napier, M., Lipari, T., Dull, T., Lee, J., and Ullrich, A.** (1988) Properties of a human insulin receptor with a COOH-terminal truncation. II. Truncated receptors have normal kinase activity but are defective in signaling metabolic effects. *J. Biol. Chem.* 263, 8912-8917
 22. **Maegawa, H., Olefsky, J., Thies, S., Boyd, D., Ullrich, A., and McClain, D.** (1988) Insulin receptors with defective tyrosine kinase inhibit normal receptor function at the level of substrate phosphorylation. *J. Biol. Chem.* 263, 12629-12637
 23. **Kahn, C. R., Baird, K. L., Jarrett, D. B., and Flier, J. S.** (1978) Direct demonstration that receptor crosslinking or aggregation is important in insulin action. *Proc. Natl. Acad. Sci. USA* 75, 4209-4213
 24. **Burgess, J. W., Wada, I., Ling, N., Khan, M. N., Bergeron, J. J., and Posner, B. I.** (1992) Decrease in beta-subunit phosphotyrosine correlates with internalization and activation of endosomal insulin receptor kinase. *J. Biol. chem.* 267, 10077-10086
 25. **Khan, M. N., Baquiran, G., Brule, C., Burgess, J., Foster, B., Bergeron, J. J., and Posner, B. I.** (1989) Internalization and activation of the rat liver insulin receptor kinase in vivo. *J. Biol. Chem.* 264, 12931-12940
 26. **Holgado-Madruga, M., Elmet, D. R., Moscatello, D. K., Godwin, A. K., and Wong, A. J.** (1996) A Grb2-associated docking protein in EGF- and insulin-receptor signalling. *Nature* 379, 560-564
 27. **Zhang-Sun, G., Yang, C., Viallet, J., Feng, G., Bergeron, J. J. M., and Posner, B. I.** (1996) A 60-kilodalton protein in rat hepatoma cells overexpressing insulin receptor was tyrosine phosphorylated and associated with Syp, phosphatidylinositol 3-kinase, and Grb2 in an insulin-dependent manner. *Endocrinology* 137, 2649-2658
 28. **Keller, S. R., and Lienhard, G.** (1994) Insulin signalling: the role of insulin receptor substrate 1. *TICB* 4, 115-119
 29. **White, M. F., and Kahn, C. R.** (1994) The insulin signaling system. *J. Biol. Chem.* 269, 1-4
 30. **White, M., and Kahn, C.** (1988) Structural and functional studies of the insulin receptor kinase. In *Insulin Receptors, Part A: Methods for the study of structure and function.* Kahn CR, Harrison L (EDs). New York. Liss , 125-145

31. **Shoelson, S. E., Chatterjee, S., Chaudhuri, M., and White, M. F. (1992)** YMXM motifs of IRS-1 define the substrate specificity of the insulin receptor kinase. *Proc. Natl. Acad. Sci. USA* 89, 2027-2031
32. **Cantley, L. C., Auger, K. R., Carpenter, C., Duckworth, B., Graziani, A., Kapeller, R., and Soltoff, S. (1991)** Oncogenes and signal transduction. *Cell* 64, 281-302
33. **Songyang, Z., Shoelson, S. E., Chadhuri, M., Gish, G., Pawson, T., Haser, W. g., King, F., Roberts, T., Ratnofsky, S., Lechleider, R. J., Neel, B. G., Birge, R. B., Fajardo, J. E. F., Chou, M. M., Harafusa, H., Schaffhausen, B., and Cantley, L. C. (1993)** SH2 domains recognize specific phosphopeptide sequences. *Cell* 72, 767-778
34. **Myers, M. G. J., Backer, J. M., Sun, X. J., Shoelson, S., Hu, P., Schlessinger, J., Yoakim, M., Schaffhausen, B., and White, M. (1992)** IRS-1 activates phosphatidylinositol 3'-kinase by associating with the src homology 2 domains of p85. *Proc. Nat. Acad. Sci. USA* 89, 10350-10354
35. **Lowenstein, E., J., Daly, R. J., Batzer, A. G., Li, W., Margolis, B., Lammers, R., Ullrich, A., Skolnik, E. Y., Bar-Sagi, D., and Schlessinger, J. (1992)** The SH2 and SH3 domain-containing protein GRB2 binds receptor tyrosine kinases to ras signaling. *Cell* 70, 431-442
36. **He, W., O'Neill, T. J., and Gustafson, T. A. (1995)** Distinct modes of interaction of SHC and insulin receptor substrate-1 with the insulin receptor NPEY region via non-SH2 domains. *J. Biol. Chem.* 270, 23258-23262
37. **Voliovitich, H., Schinder, D. G., Hadari, Y. R., Taylor, S. I., Accili, D., and Zick, Y. (1995)** Tyrosine phosphorylation of insulin receptor substrate-1 in vivo depends upon the presence of its pleckstrin homology region. *J. Biol. Chem.* 270, 18083-18087
38. **Touhara, K., Inglese, J., Pitcher, J. A., Shaw, G., and Lefkowitz, R. J. (1994)** Binding of G protein bg-subunits to pleckstrin homology domains. *J. Biol. Chem.* 269, 10217-10220
39. **Tamemoto, H., Kadowaki, T., Tobe, K., Yagi, T., Sakura, H., Hayakawa, T., Terauchi, Y., Ueki, K., Kaburagi, Y., Satoh, S., Sekihara, H., Yoshioka, S., Horikoshi, H., Futura, Y., Ikawa, Y., Kasuga, M., Yazaki, Y., and Aizawa, S. (1994)** Insulin resistance and growth retardation in mice lacking insulin receptor substrate-1. *Nature* 372, 182-186
40. **Araki, E., Lipes, M., Patti, M., Bruning, J., Haag III, B., Johnson, R., and Kahn, C. (1994)** Alternative pathway of insulin signalling in mice with targeted disruption of the IRS-1 gene. *Nature* 372, 186-190
41. **Pelicci, G., Lanfrancone, L., Grignani, F., McGlade, J., Forni, G., Nicoletti, I., Grignani, F., Pawson T., and Pelicci, P. G. (1992)** A novel transforming protein (SHC) with an SH2 domain is implicated in mitogenic signal transduction. *Cell* 70, 93-104
42. **Pronk, G. J., McGlade, J., Pelicci, G., Pawson, T., and Bos, J. L. (1993)** Insulin-induced phosphorylation of the 46-and 52-kDa Shc proteins. *J. Biol. chem.* 268, 5748-5753
43. **Pronk, G. J., and Bos, J. L. (1994)** The role of p21^{ras} in receptor kinase signalling. *Biochem. Biophys. Acta* 1198, 131-147
44. **Skolnik, E. Y., Lee, C.-H., Batzer, A., Vicentini, L. M., Zhou, M., Daly, R., Myers, M. J., Backer, J. M., Ullrich, A., White, M. F., and**

- Schlessinger, J.** (1993) The SH2/SH3 domain-containing protein GRB2 interacts with tyrosine-phosphorylated IRS1 and Shc: implications for insulin control of ras signalling. *EMBO J.* 12, 1929-1936
45. **Fry, M. J.** (1994) Structure, regulation and function of phosphoinositide 3-kinases *Biochim Biophys Acta* 1226, 237-268
46. **Antonetti, D. A., and Kahn, R. C.** (1995) IRS-1 binds novel forms of PI 3-kinase in human skeletal muscle. *Diabetes* 44 (Suppl. 1), 20A
47. **Folli, F., Saad, M. J., Backer, J. M., and Kahn, C. R.** (1992) Insulin stimulation of phosphatidylinositol 3-kinase activity and association with insulin receptor substrate 1 in liver and muscle of the intact rat. *J. Biol. Chem.* 267, 22171-22177
48. **Sung, C. K., Sanchez-Margalet, V., and Goldfine, I. D.** (1994) Role of p85 subunit of phosphatidylinositol 3-kinase as an adaptor molecule linking the insulin receptor, p62, and GTPase-activating protein. *J. Biol. Chem.* 269, 12503-12507
49. **Pleiman, C. M., Hertz, W.M., and Cambier, J.C.** (1994) Activation of phosphatidylinositol-3' kinase by Src-family kinase SH3 binding to the p85 subunit. *Science* 263, 1609-1612
50. **Liu, X., Marengere, L.E.M., Koch, C.A., Pawson, T.** (1993) The v-Src SH3 domain binds phosphatidylinositol 3-kinase. *Mol. Cell. Biol.* 13, 5225-5232
51. **Stephens, L., Smrcka, A., Cooke, F. T., Jackson, T. R., Sternweis, P. C., and Hawkins, P. T.** (1994) A novel phosphoinositide 3-kinase activity in myeloid-derived cells is activated by G Protein $\beta\gamma$ subunits. *Cell* 77, 83-93
52. **Thomason, P. A., James, S. R., Casey, P. J., and Downes, C. P.** (1994) A G-protein $\beta\gamma$ -subunits-responsive phosphoinositide 3-kinase activity in human platelet cytosol. *J. Biol. Chem.* 269, 16525-16528
53. **Stoyanov, B., Volinia, S., Hanck, T., Rubio, I., Loubtchenkov, M., Malek, D., Stoyanova, S., Vanhaesebroeck, B., Dhand, R., Nurnberg, B., Gierschik, P., Sedorf, K., Justin Hsuan, J., Waterfield, M., and Wetzker, R.** (1995) Cloning and characterization of a G protein-activated human phosphoinositide-3 kinase. *Science* 269, 690-693
54. **Volinia, S., Dhand, R., Vanhaesebroeck, B., MacDougall, L. K., Stein, R., Zvelebil, M. J., Domin, J., Panaretou, C., and Waterfield, M. D.** (1995) A human phosphatidylinositol 3-kinase complex related to the yeast Vps34p-Vps15p protein sorting system. *EMBO J.* 14, 3339-3348
55. **Rodriguez-Viciana, P., Warne, P. H., Dhand, R., Vanhaesebroeck, B., Gout, I., Fry, M. J., Waterfield, M. D., and Downward, J.** (1995) Phosphatidylinositol-3-OH kinase as a direct target of Ras. *Nature*
56. **Tolias, K. F., Cantley, L. C., and Carpenter, C. L.** (1995) Rho family GTPases bind to phosphoinositide kinases. *J. Biol. Chem.* 270, 17656-17659
57. **Kotani, K., Yonezawa, K., Hara, K., Ueda, H., Kitamura, Y., Sakaue, H., Ando, A., Chavanieu, A., Calas, B., Grigorescu, F., Nishiyama, M., Waterfield, M. D., and Kasuga, M.** (1994) Involvement of phosphoinositide 3-kinase in insulin- or IGF-1-induced membrane ruffling. *EMBO J* 13, 2313-2321
58. **Ruderman, N., Kapeller, R., White, M. F., and Cantley, L. C.** (1990) Activation of phosphatidylinositol 3-kinase by insulin. *Proc. Natl. Acad. Sci.* 87, 1411-1415
59. **Chen, K. S., Friel, J. C., and Ruderman, N.** (1993) Regulation of phosphatidylinositol 3-kinase by insulin in rat skeletal muscle. *Am. J. Physiol.* 265, E736-E742

60. **Yeh, J., Culve, E. A., Rameh, L., and Birnbaum, M. J.** (1995) The effects of wortmannin on rat skeletal muscle. Dissociation of signaling pathways for insulin - and contraction -activated hexose transport. *J. Biol. Chem.* 270(5), 2107-2111
61. **Okada, T., Kawano, Y., Sakakibara, T., Hazeki, O., and Ui, M.** (1994) Essential role of phosphatidylinositol 3-kinase in insulin-induced glucose transport and antilipolysis in rat adipocytes. *J. Biol. Chem.* 269, 3568-3573
62. **Lamphere, L., Carpenter, C. L., Sheng, Z.-F., Kallen, R. G., and Lienhard, G. E.** (1994) Activation of PI 3-kinase in 3T3-L1 adipocytes by association with insulin receptor substrate-1. *Am. J. Physiol.* 266, E486-E494
63. **Cheatham, B., Vlahos, C. J., Cheatham, L., Wang, L., Blenis, J., and Kahn, C. R.** (1994) Phosphatidylinositol 3-kinase activation is required for insulin stimulation of pp70 S6 kinase, DNA synthesis and glucose transporter translocation. *Mol. Cell. Biol.* 14, 4902-11
64. **Clarke, J. F., Young, P. W., Yonezawa, K., Kasuga, M., and Holman, G. D.** (1994) Inhibition of the translocation of GLUT1 and GLUT4 in 3T3-L1 cells by the phosphatidylinositol 3-kinase inhibitor, wortmannin. *Biochem. J.* 300, 6311-635
65. **Tsakiridis, T., McDowell, H. E., Walker, T., Downes, C. P., Hundal, H. S., Vranic, M., and Klip, A.** (1995) Multiple roles of phosphatidylinositol 3-kinase in regulation of glucose transport, amino acid transport, and glucose transporters in L6 skeletal muscle cells. *Endocrinology* 136, 4315-4322
66. **Backer, J. M., Myers Jr., M. G., Sun, X.-J., Chin, D. J., Shoelson, S. E., Miralpeix, M., and White, M. F.** (1993) Association of IRS-1 with the insulin receptor and the phosphatidylinositol 3'-kinase. *J. Biol. Chem.* 268, 8204-8212
67. **Kelly, K., and Ruderman, N. B.** (1992) Insulin-stimulated phosphatidylinositol 3-kinase. Association with a 185 kDa tyrosine-phosphorylated protein (IRS-1) and localization in a low density membrane vesicle. *J. Biol. Chem.* (267), 3423-3428
68. **Van Horn, D. J., Myers Jr., M. G., and Backer, J. M.** (1993) Direct activation of the phosphatidylinositol 3'-kinase by the insulin receptor. *J. Biol. Chem.* 269, 29-32
69. **Staubs, P. A., Reichart, D. R., Saltiel, A. R., Milarski, K. L., Maegawa, H., Berhanu, P., Olefsky, J. M., and Seely, B. L.** (1994) Localization of the receptor binding sites for the SH2 domain proteins p85, Syp and GAP. *J. Biol. Chem.* 269, 27186-27192
70. **Levy-Toledano, R., Taouis, M., Blaettler, D. H., Gorden, P., and Taylor, S. I.** (1994) Insulin-induced activation of phosphatidylinositol 3-kinase: demonstration that the p85 subunit binds directly to the COOH terminus of the insulin receptor in intact cells. *J. Biol. Chem.* 269(49), 31178-31182
71. **Lam, K., Carpenter, C. L., Ruderman, N. B., Friel, J. C., and Kelly, K. L.** (1994) The Phosphatidylinositol 3-kinase serine kinase phosphorylates IRS-1. *J. Biol. Chem.* 269, 20648-20652
72. **Dhand, R., Hiles, I., Panayotou, G., Roche, S., Fry, M. J., Gout, I., Totty, N. F., Truong, O., Vicendo, P., Yonezawa, K., Kasuga, M., Courtneidge, S. A., and Waterfield, M. D.** (1994) PI 3-kinase is a dual specificity enzyme: autoregulation by an intrinsic protein-serine kinase activity. *EMBO J.* 13, 522-533
73. **Serunian, L. A., Haber, M. T., Fukui, T., Kim, J. W., Rhee, S. G., Lowenstein, J. M., and Cantley, L. C.** (1989) Polyphosphoinositides produced

- by phosphatidylinositol 3-kinase are poor substrates for phospholipase C from rat liver and bovine brain. *J. Biol. Chem.* 264, 17809-17815
74. **Nakanishi, H., Brewer, K. A., and Exton, J. H.** (1993) Activation of the ζ isozyme of protein kinase C by phosphatidylinositol 3,4,5-trisphosphate. *J. Biol. Chem.* 268, 13-16
75. **Toker, A., Meyer, M., Reddy, K. K., Falck, J. R., Aneja, R., Aneja, S., Parra, A., Burns, D. J., Ballas, L. M., and Cantley, L. C.** (1994) Activation of protein kinase C family members by the novel polyphosphoinositides PtdIns-3,4-P₂ and PtdIns-3,4,5-P₃. *J. Biol. Chem.* 269, 32358-32367
76. **Franke, T. F., Yang, S.-I., Chan, T. O., Datta, K., Kazlauskas, A., Morrison, D. K., Kaplan, D. R., and Tschlis, P. N.** (1995) The protein kinase encoded by the *Akt* proto-oncogene is a target of the PDGF-activated phosphatidylinositol 3-kinase. *Cell* 81, 727-736
77. **Kohn, A. D., Kovacina, K. S., and Roth, R. A.** (1995) Insulin stimulates the kinase activity of RAC-PK, a pleckstrin homology domain containing ser/thr kinase. *EMBO J.* 14, 4288-4295
78. **Burgering, B. M., and Coffey, P. J.** (1995) Protein kinase B (c-Akt) in phosphatidylinositol-3-OH kinase signal transduction. *Nature* 376, 599-602
79. **Jhun, B. H., Rose, D. W., Seely, B. L., Rameh, L., Cantley, L., Saltiel, A. R., and Olefsky, J. M.** (1994) Microinjection of the SH2 domain of the 85-kilodalton subunit of phosphatidylinositol 3-kinase inhibits insulin-induced DNA synthesis and *c-fos* expression. *Mol. Cell Biol.* 14, 7466-7475
80. **Cross, D. A. E., Alessi, D. R., Cohen, P., Andjelkovich, M., and Hemmings, B. A.** (1995) Inhibition of glycogen synthase kinase-3 by insulin mediated by protein kinase B *Nature* 378, 785-789
81. **Tsakiridis, T., Vranic, M., and Klip, A.** (1995) Phosphatidylinositol 3-kinase and the actin network are not required for the stimulation of glucose transport caused by mitochondrial uncoupling: comparison with insulin action. *Biochem. J.* 309, 1-5
82. **Ui, M., Okada, T., Hazeki, K., and Hazeki, O.** (1995) Wortmannin as a unique probe for an intracellular signalling protein, phosphoinositide 3-kinase. *TIBS* 20, 303-307
83. **Vlahos, C. J., Matter, W. F., Hui, K. Y., and Brown, R. F.** (1994) A specific inhibitor of phosphatidylinositol 3-kinase, 2-(4-Morpholinyl)-8-phenyl-4H-1-benzopyran-4-one (LY294002). *J Biol Chem* 269, 5241-5248
84. **Varticovski, L., Harrison-Findik, D., Keeler, M. L., and Susa, M.** (1994) Role of PI 3-kinase in mitogenesis. *Biochim. Biophys. Acta* 1226, 1-11
85. **Myers Jr., M. G., Grammer, T. C., Wang, L. M., Sun, X. J., Pierce, J. H., Blenis, J., and White, M. F.** (1994) Insulin receptor substrate-1 mediates phosphatidylinositol 3'-kinase and p70S6k signaling during insulin, insulin-like growth factor-1 and interleukin-4 stimulation. *J. Biol. Chem.* 269, 28783-28789
86. **Chung, J., Grammer, T. C., Lemon, K. P., Kazlauskas, A., and Blenis, J.** (1994) PDGF- and insulin-dependent pp70S6k activation mediated by phosphatidylinositol 3-OH-kinase. *Nature* 370, 71-75
87. **Weng, Q.-P., Andrabi, K., Klippel, A., Kozłowski, M. T., Williams, L. T., and Avruch, J.** (1995) Phosphatidylinositol 3-kinase signals activation of p70 S6 kinase in situ through site-specific p70 phosphorylation. *Proc. Natl. Acad. Sci. USA* 92, 5744-5748

88. **Hara, K., Yonezawa, K., Sakaue, H., Ando, A., Kotani, K., Kitamura, T., Kitamura, Y., Ueda, H., Stephens, L., Dhand, R., Clark, A. E., Holman, G. D., Waterfield, M. D., and Kasuga, M.** (1994) 1-Phosphatidylinositol 3-kinase activity is required for insulin-stimulated glucose transport but not for RAS activation in CHO cells. *Proc. Natl. Acad. Sci. U.S.A.* 91, 7415-7419
89. **Tanti, J. F., Gremeaux, T., Van Obberghen, E., and Le, M.-B. Y.** (1994) Serine/threonine phosphorylation of insulin receptor substrate 1 modulates insulin receptor signaling. *J. Biol. Chem.* 269(8), 6051-6057
90. **Skolnik, E. Y., Batzer, A., Li, N., Lee, C. H., Lowenstein, E., Mohammadi, M., Margolis, B., and Schlessinger, J.** (1993) The function of GRB2 in linking the insulin receptor to Ras signaling pathways. *Science* 260, 1953-1955
91. **Uehara, T., Tokumitsu, Y., and Nomura, Y.** (1995) Wortmannin inhibits insulin-induced Ras and mitogen-activated protein kinase activation related to adipocyte differentiation in 3T3-L1 fibroblasts. *Biochem. Biophys. Res. Commun.* 210, 574-580
92. **Quilliam, L. A., khosravi-Far, R., Huff, S. Y., and Der, C. J.** (1995) Guanine nucleotide exchange factors: activators of the Ras superfamily of proteins. *Bioessays* 17, 395-404
93. **Waters, S. B., Yamauchi, K., and Pessin, J. E.** (1995) Insulin-stimulated disassociation of the SOS-Grb2 complex. *Mol. Cell. Biol.* 15, 2791-2799
94. **Cherniack, A. D., Klarlund, J. K., Conway, B. R., and Czech, M. P.** (1995) Disassembly of son-of-sevenless proteins from Grb2 during p21^{ras} desensitization by insulin. *J. Biol. Chem.* 270(4), 1485-1488
95. **Langois, W. J., Sasaoka, T., saltiel, A. R., and Olefsky, J. M.** (1995) Negative feedback regulation and desensitization of insulin-and epidermal growth factor-stimulated p21 ras activation. *J. Biol. Chem.* 270, 25320-25323
96. **Bos, J. L.** (1989) ras oncogenes in human cancer: a review. *Cancer Res.* 49, 4682-4689
97. **Medema, R. H., Wubblots, R., and Bos, J. L.** (1991) Two dominant inhibitory mutants of p21^{ras} interfere with insulin-induced gene expression. *Mol. Cell. Biol.* 11, 5963-5967
98. **Schlessinger, J.** (1993) How tyrosine kinases activate Ras. *TIBS* 18, 273-275
99. **Jhun, B. H., Meinkoth, J. L., Leitner, J. W., Draznin, B., and Olefsky, J. M.** (1994) Insulin and Insulin-like Growth Factor-1 signal transduction requires p21 ras. *J. Biol. Chem.* 269, 5699-5704
100. **Burgering, B. M., Medema, R. H., Maassen, J. A., van de Wetering, M. L., van der Eb, A. J., McCormick, F., and Bos, J. L.** (1991) Insulin stimulation of gene expression mediated by p21ras activation. *EMBO J.* 10, 1103-1109
101. **Kovacina, K. S., Yonezawa, K., Brautigan, D. L., Tonks, N. K., Rapp, U. R., and Roth, R. A.** (1990) Insulin activates the kinase activity of raf-1 proto-oncogene by increasing its serine phosphorylation. *J. Biol. Chem.* 265, 12115-12118
102. **Stokoe, D., Macdonald, S. G., Cadwallader, K., Symons, M., and Hancock, J. F.** (1994) Activation of Raf as a result of recruitment to the plasma membrane. *Science* 264, 1463-1466
103. **Feig, L. A., and Schaffhausen, B.** (1994) The hunt for Ras targets. *Nature* 370, 508-509
104. **Seger, R., Ahn, N. G., Boulton, T. G., Yancopoulos, G. D., Panayotatos, N., Radziejewska, E., Ericsson, L., Bratlien, R. L., Cobb, M. H., and Krebs, E. G.** (1991) Microtubule-associated protein 2 kinases, ERK1

- and ERK2, undergo autophosphorylation on both tyrosine and threonine residues: implications for their mechanism of action. *Proc. Natl. Acad. Sci. USA* 88, 6142-6146
105. **O'Brien, R. M., and Granner, D. K.** (1991) Regulation of gene expression by insulin. *Biochem. J.* 278, 609-619
 106. **Kim, S.-J., and Kahn, C. R.** (1994) Insulin stimulates c-Jun, c-Fos, and Fos-related proteins in cultured adipocytes. *J. Biol. Chem.* 269, 11887-11892
 107. **Sale, E. M., Atkinson, P. G. P., and Sale, G.** (1995) Requirement of MAP kinase for differentiation of fibroblasts to adipocytes, for insulin activation of p90 S6 kinase and for insulin or serum stimulation of DNA synthesis. *EMBO J.* 14, 674-684
 108. **Dent, P., Lavoigne, A., Nakielny, S., Caudwell, F. B., Watt, P., and Cohen, P.** (1990) The molecular mechanisms by which insulin stimulates glycogen synthesis in mammalian skeletal muscle. *Nature* 348, 302-307
 109. **Azpiazu, I., Saltiel, A. R., DePaoli-Roach, A. A., and Lawrence Jr, J. C.** (1996) Regulation of both glycogen synthase and PHAS-I by insulin in rat skeletal muscle involves mitogen-activated protein kinase-independent and rapamycin-sensitive pathways. *J. Biol. Chem.* 271, 5033-5039
 110. **Bell, G. I., Burant, C. F., Takeda, J., and Gould, G. W.** (1993) Structure and function of mammalian facilitative sugar transporters. *J. Biol. Chem.* 268, 19161-19164
 111. **Wright, E. M., Hirayama, B., Hazama, A., Loo, D. D., Supplison, S., Turk, E., and Hager, K. M.** (1993) The sodium/glucose cotransporter (SGLT1). *Society of General Physiologists Series.* 48, 229-241
 112. **Bell, G. I., Kayano, T., Buse, J. B., Burant, C. F., Takeda, J., Lin, D., Fukumoto, H., and Seino, S.** (1990) Molecular biology of mammalian glucose transporters. *Diabetes Care* 13(3), 198-208
 113. **Thorens, B., Charron, M. J., and Lodish, H. F.** (1990) Molecular physiology of glucose transporters. *Diabetes Care* 13(3), 209-218
 114. **Gould, G. W., and Bell, G. I.** (1990) Facilitative glucose transporters: an expanding family *TIBS* 15, 18-23
 115. **James, D. E.** (1995) The mammalian facilitative glucose transporter family. *NIPS* 10, 67-71
 116. **Mueckler, M., Caruso, C., Baldwin, S., Panico, M., Blench, I., Morris, H., Allard, W., Lienhard, G., and Lodish, H.** (1985) Sequence and structure of a human glucose transporter. *Science* 229, 941-945
 117. **James, D. E., Brown, R., Navarro, J., and Pilch, P. F.** (1988) Insulin-regulatable tissues express a unique insulin-sensitive glucose transport protein. *Nature* 333(6169), 183-5
 118. **Fukumoto, H., Seino, S., Imura, H., Seino, Y., Eddy, R. L., Fukushima, Y., Byers, M. G., Shows, T. B., and Bell, G. I.** (1988) Sequence, tissue distribution, and chromosomal localization of mRNA encoding a human glucose transporter-like protein. *Proc. Natl. Acad. Sci. U.S.A.* 85(15), 5434-5438
 119. **Orci, L., Thorens, B., Ravazzola, M., and Lodish, H. F.** (1989) Localization of the pancreatic beta cell glucose transporter to specific plasma membrane domains. *Science* 245, 295-297
 120. **Kayano, T., Fukumoto, H., Eddy, R. L., Fan, Y.-S., Byers, M. G., Shows, T. B., and Bell, G. I.** (1988) Evidence for a family of human glucose transporter-like proteins. Sequence and gene localization of a protein expressed in fetal skeletal muscle and other tissues. *J. Biol. Chem.* 263(30), 15245-15248

121. **Guillet-Deniau, I., Leturque, A., and Girard, J.** (1994) Expression and cellular localization of glucose transporters (GLUT1, GLUT3, GLUT4) during differentiation of myogenic cells isolated from rat fetuses. *J. Cell. Sci.* 107, 487-496
122. **Charron, M. J., Brosius, F. C. d., Alper, S. L., and Lodish, H. F.** (1989) A glucose transport protein expressed predominately in insulin-responsive tissues. *Proc. Natl. Acad. Sci. U.S.A.* 86(8), 2535-2539
123. **Fukumoto, H., Kayano, T., Buse, J. B., Edwards, Y., Pilch, P. F., Bell, G. I., and Seino, S.** (1989) Cloning and characterization of the major insulin-responsive glucose transporter expressed in human skeletal muscle and other insulin-responsive tissues. *J. Biol. Chem.* 264(14), 7776-7779
124. **James, D., Strube, M., and Mueckler, M.** (1989) Molecular cloning and characterization of an insulin-regulatable glucose transporter. *Nature* 338, 83-87
125. **Keller, K., Strube, M., and Mueckler, M.** (1989) Functional expression of the human HepG2 and rat adipocyte glucose transporters in *Xenopus* oocytes. Comparison of kinetic parameters. *J. Biol. Chem.* 264(32), 18884-18889
126. **Gould, G. W., Thomas, H. M., Jess, T. J., and Bell, G. I.** (1991) Expression of human glucose transporters in *Xenopus* oocytes: Kinetic characterization and substrate specificities of the erythrocyte, liver and brain isoforms *Biochemistry* 30, 5139-5145
127. **Klip, A., Ramlal, T., Young, D. A., and Holloszy, J. O.** (1987) Insulin-induced translocation of glucose transporters in rat hindlimb muscles. *FEBS Lett.* 224, 224-230
128. **Slot, J. W., Geuze, H. J., Gigengack, S., James, D. E., and Lienhard, G. E.** (1991) Translocation of the glucose transporter GLUT4 in cardiac myocytes of the rat. *Proc. Natl. Acad. Sci. U.S.A.* 88(17), 7815-7819
129. **Blakemore, S. J., Aledo, J. C., James, J., Campbell, F. C., Lucocq, J. M., and Hundal, H. S.** (1995) The GLUT5 hexose transporter is also localized to the basolateral membrane of the human jejunum. *Biochem. J.* 309, 7-12
130. **Kayano, T., Burant, C. F., Fukumoto, H., Gould, G. W., Fan, Y. S., Eddy, R. L., Byers, M. G., Shows, T. B., Seino, S., and Bell, G. I.** (1990) Human facilitative glucose transporters. Isolation, functional characterization, and gene localization of cDNAs encoding an isoform (GLUT5) expressed in small intestine, kidney, muscle, and adipose tissue and an unusual glucose transporter pseudogene-like sequence (GLUT6). *J. Biol. Chem.* 265(22), 13276-13282
131. **Hundal, H. S., Ahmed, A., Guma, A., Mitsumoto, Y., Marette, A., Rennie, M. J., and Klip, A.** (1992) Biochemical and immunocytochemical localization of the GLUT5 glucose transporter in human skeletal muscle. *Biochem. J.* 286, 339-343
132. **Shepherd, P. E., Gibbs, E. M., Wesslau, C., and Gould, G. W.** (1992) Human small intestine facilitative fructose/glucose transporter (GLUT5) is also present in insulin-responsive tissues and brain: Investigation of biochemical characteristics and translocation *Diabetes* 41, 1360-1365
133. **Burant, C. F., Takeda, J., Brot-Laroche, E., Bell, G. I., and Davidson, N. O.** (1992) Fructose transporter in human spermatozoa and small intestine GLUT5 *J. Biol. Chem.* 267, 14523-14526
134. **Ahlborg, G., and Bjorkman, O.** (1990) Splanchnic and muscle fructose metabolism during and after exercise *J. App. Physiol.* 69, 1244-1251

135. **Waddell, I. D., Zomerschoe, A. G., Voice, M. W., and Burchell, A.** (1992) Cloning and expression of a hepatic microsomal glucose transport protein. *Biochem. J.* 286, 173-177
136. **Wardzala, L. J., Cushman, S. W., and Salans, L. B.** (1978) Mechanism of insulin action on glucose transport in the isolated rat adipose cell. *J. Biol. Chem.* 253, 8002-8003
137. **Wardzala, L. J., and Jeanrenaud, B.** (1983) Identification of the D-glucose-inhibitable cytochalasin B binding site as the glucose transporter in rat diaphragm plasma and microsomal membranes. *Biochim. Biophys. Acta* 730, 49-56
138. **Suzuki, K., and Kono, T.** (1980) Evidence that insulin causes translocation of glucose transport activity to the plasma membrane from an intracellular storage site. *Proc. Natl. Acad. Sci. U.S.A.* 77, 2542-2545
139. **Stephens, J. M., and Pilch, P. F.** (1995) The metabolic regulation and vesicular transport of GLUT4, the major insulin-responsive glucose transporter. *Endocrinology* 16, 529-546
140. **Rodnick, K. J., Slot, J.W., Studelska, D.R., Hanpeter, D.E., Robinson, L.J., Geuze, H.J., and James, D.E.** (1992) Immunocytochemical and biochemical studies of GLUT4 in rat skeletal muscle. *J. Biol. Chem.* 267, 6278-6285
141. **Kahn, B. B., and Cushman, S. W.** (1985) Subcellular translocation of glucose transporters: role in insulin action and its perturbation in altered metabolic states. *Diabetes Metab. Rev.* 1(3), 203-27
142. **Kahn, B. B., Cushman, S. W., and Flier, J. S.** (1989) Regulation of glucose transporter-specific mRNA levels in rat adipose cells with fasting and refeeding. Implications for in vivo control of glucose transporter number. *J. Clin. Invest.* 83(1), 199-204
143. **Kahn, B. B., Simpson, I. A., and Cushman, S. W.** (1988) Divergent mechanisms for the insulin resistant and hyperresponsive glucose transport in adipose cells from fasted and refed rats. Alterations in both glucose transporter number and intrinsic activity. *J. Clin. Invest.* 82(2), 691-9
144. **Klip, A., Ramlal, T., Cartee, G., Gulve, E., and Holloszy, J. O.** (1990) Insulin-induced recruitment of glucose transporters to the plasma membrane in skeletal muscle from diabetic rats *Biophys. Res. Commun.* 172, 728-736
145. **Baron, A. D., Brechtel, G., Wallace, P., and Edelman, S. V.** (1988) Rates and tissue sites of non-insulin- and insulin-mediated glucose uptake in humans *Am J Physiol* 255, E769-74
146. **Holman, G. D., Karim, A. R., and Karim, B.** (1988) Photolabeling of erythrocyte and adipocyte hexose transporters using a benzophenone derivative of bis(D-mannose). *Biochim. Biophys. Acta* 946(1), 75-84
147. **Holman, G. D., Kozka, I. J., Clark, A. E., Flower, C. J., Saltis, J., Habberfield, A. D., Simpson, I. A., and Cushman, S. W.** (1990) Cell surface labeling of glucose transporter isoform GLUT4 by bis-mannose photolabel. Correlation with stimulation of glucose transport in rat adipose cells by insulin and phorbol ester. *J. Biol. Chem.* 265(30), 18172-9
148. **Kotliar, N., and Pilch, P. F.** (1992) Expression of the glucose transporter isoform GLUT4 is insufficient to confer insulin-regulatable hexose uptake to cultured muscle cells. *Mol. Endocrinol.* 6, 337-345

149. **King, P. A., Hirshman, M. F., Horton, E. D., and Horton, E. S. (1989)** Glucose transport in skeletal muscle plasma membrane vesicles from control and exercised rats. *Am. J. Physiol.* 257, C1128-C1134
150. **Hudson, A. W., Fingar, D. C., Seidner, G. A., Griffiths, G., Burke, B., and Birnbaum, M. J. (1993)** Targeting of the "insulin-responsive" glucose transporter (GLUT4) to the regulated secretory pathway in PC12 cells. *J. Cell Biol.* 122, 579-588
151. **Cain, C. C., Trimble, W. S., and Lienhard, G. E. (1992)** Members of the VAMP family of synaptic vesicle proteins are components of the glucose transporter-containing vesicle from rat adipocytes. *J. Biol. Chem.* 267, 11681-11684
152. **Volchuk, A., Sargeant, R., Sumitani, S., Liu, Z., He, L., and Klip, A. (1995)** Cellubrevin is a resident protein of insulin-sensitive GLUT4 glucose transporter vesicles in 3T3-L1 adipocytes. *J. Biol. Chem.* 270, 8233-8240
153. **Robinson, L. J., and James, D.E. (1992)** Insulin-regulated sorting of glucose transporters in 3T3-L1 adipocytes. *Am. J. Physiol.* 263, E383-E393
154. **Slot, J. W., Geuze, H. J., Gigengack, S., Lienhard, G. E., and James, D. E. (1991)** Immuno-localization of the insulin regulatable glucose transporter in brown adipose tissue of the rat. *J. Cell. Biol.* 113(1), 123-35
155. **Nishimura, H., Zarnowski, M. J., and Simpson, I. A. (1993)** Glucose transporter recycling in rat adipose cells. *J. Biol. Chem.* 268, 19246-19253
156. **Yang, J., and Holman, G. D. (1993)** Comparison of GLUT4 and GLUT1 subcellular trafficking in basal and insulin-stimulated 3T3-L1 cells. *J Biol Chem* 268(7), 4600-4603
157. **Kandror, K., and Pilch, P. (1994)** Identification and isolation of glycoproteins that translocate to the cell surface from GLUT4-enriched vesicles in an insulin-dependent fashion. *J. Biol. Chem.* 269, 138-142
158. **Jhun, B. H., Rampal, A. L., Liu, H., Lachaal, M., and Jung, C. Y. (1992)** Effects of insulin on steady state kinetics of GLUT4 subcellular distribution in rat adipocytes. *J. Biol. Chem.* 267(25), 17710-15
159. **Czech, M. P., and Buxton, J.M. (1993)** Insulin action on the internalization of the GLUT4 glucose transporter in isolated rat adipocytes. *J. Biol. Chem.* 268(13), 9187-9190
160. **Lund, S., Holman, G. D., Schmitz, O., and Pedersen, O. (1995)** Contraction stimulates translocation of glucose transporter GLUT4 in skeletal muscle through a mechanism distinct from that of insulin. *PNAS* 92, 5817-5821
161. **LeMarchand-Brustel, Y., Gautier, N., Cormont, M., and E., V. O. (1995)** Wortmannin inhibits the action of insulin but not that of okadaic acid in skeletal muscle: Comparison with fat cells. *Endocrinology* 136, 3564-3570
162. **Kotani, K., Carozzi, A. J., Sakaue, H., Hara, K., Robinson, L. J., Clark, S. F., Yonezawa, K., James, D. E., and Kasuga, M. (1995)** Requirement for phosphoinositide 3-kinase in insulin-stimulated GLUT4 translocation in 3T3-L1 adipocytes. *Biochem. Biophys. Res. Comm.* 209, 343-348
163. **Folli, F., Saad, M. J. A., Backer, J. M., and Kahn, C. R. (1993)** Regulation of phosphatidylinositol 3-kinase activity in liver and muscle of animal models of insulin-resistant and insulin-deficient diabetes mellitus. *J. Clin. Invest.* 92, 1787-11794

164. **Heydrick, S. J., Jullien, D., Gautier, N., Tanti, J.F., Giorgetti, S., Van Obberghen, E., Le Marchand-Brustel, Y.** (1993) Defect in skeletal muscle phosphatidylinositol-3-kinase in obese insulin-resistant mice. *J. Biol. Chem.* 268, 1358-11366
165. **Rondinone, C. M., and Smith, U.** (1996) Okadaic acid exerts a full insulin-like effect on glucose transport and glucose transporter 4 translocation in human adipocytes. *J. Biol. Chem.* 271, 18148-18153
166. **Isakoff, S. J., Taha, C., Rose, E., Marcusohn, J., Klip, A., and Skolnic, E. Y.** (1995) The inability of phosphatidylinositol 3-kinase activation to stimulate GLUT4 translocation indicates additional signaling pathways are required for insulin-stimulated glucose uptake. *Proc. Natl. Acad. Sci. USA* 92, 10247-10251
167. **Martin, S. S., Haruta, T., Morris, A. J., Klippel, A., Williams, L. T., and Olefsky, J. M.** (1996) Activated phosphatidylinositol 3-kinase is sufficient to mediate actin rearrangement and GLUT4 translocation in 3T3-L1 adipocytes. *J. Biol. Chem.* 271, 17605-17608
168. **Hausdorf, S. F., Frangioni, J. V., and Birnbaum, M. J.** (1994) Role of p21 ras in insulin-stimulated glucose transport in 3T3-L1 adipocytes. *J. Biol. Chem.* 269, 21391-21394
169. **van den Berghe, N., Ouwens, D. M., Maassen, J. A., van Mackelenbergh, M. G. H., Sips, H. C. M., and Krans, H. M. J.** (1994) Activation of the Ras/Mitogen-activated protein kinase signaling pathway alone is not sufficient to induce glucose uptake in 3T3-L1 adipocytes. *Mol. Cell. Biol.* 14, 2372-2377
170. **Kozma, L., Baltensperger, B., Klarlund, J., Porras, A., Santos, E., and Czech, M. P.** (1993) The Ras signaling pathway mimics insulin action on glucose transporter translocation. *Proc. Natl. Acad. Sci. U.S.A.* 90, 4460-4464
171. **Quon, M. J., Chen, H., Ing, B. L., Liu, M.-L., Zarnowski, M. J., Yonezawa, K., Kasuga, M., Cushman, S. W., and Taylor, S. I.** (1995) Role of 1-phosphatidylinositol 3-kinase and ras in regulating translocation of GLUT4 in transfected rat adipose cells. *Mol. Cell. Biol.* 15, 5403-5411
172. **Fingar, D. C., and Birnbaum, M.** (1994) A role for Raf-1 in the divergent signaling pathways mediating insulin-stimulated glucose transport. *J. Biol. Chem.* 269, 10127-10132
173. **Robinson, L. J., Razzack, Z. F., Lawrence Jr., J. C., and James, D. E.** (1993) Mitogen-activated protein kinase activation is not sufficient for stimulation of glucose transport or glycogen synthase in 3T3-L1 adipocytes. *J. Biol. Chem.* 268, 26422-26427
174. **Fingar, D. C., and Birnbaum, M. J.** (1994) Characterization of the mitogen-activated protein kinase/90-kilodalton ribosomal protein S6 kinase signaling pathway in 3T3-L1 adipocytes and its role in insulin-stimulated glucose transport. *Endocrinology* 134, 728-735
175. **Newton, A. C.** (1995) Protein kinase C: Structure, Function, and regulation. *J. Biol. Chem.* 270, 28495-28498
176. **Nishizuka, Y.** (1992) Intracellular signaling by hydrolysis of phospholipids and activation of protein kinase C. *Science* 258, 607-614
177. **Henriksen, E. J., Rodnick, K. J., and Holloszy, J. O.** (1989) Activation of glucose transport in skeletal muscle by phospholipase C and phorbol ester; Evaluation of the regulatory roles of protein kinase C and calcium. *J. Biol. Chem.* 264, 21536-21543

178. **Klip, A., and Ramlal, T.** (1987) Protein kinase C is not required for insulin stimulation of hexose uptake in muscle cells in culture. *Biochem. J.* 242, 131-136
179. **Tanti, J. F., Rochet, N., Gremeaux, T., Van Obberghen, E., and Le Marchand-Brustel, Y.** (1989) Insulin-stimulated glucose transport in muscle; Evidence for protein-kinase-C-dependent component which is unaltered in insulin-resistant mice *Biochem. J.* 258, 141-146
180. **Ishizuka, T., Cooper, D. R., Hernandez, H., Buckley, D., Standaert, M., and Farese, R. V.** (1990) Effects of insulin on diacylglycerol-protein kinase C signaling in rat diaphragm and soleus muscles and relationship to glucose transport. *Diabetes* 39, 181-190
181. **Yu, B., Standaert, M., Arnold, T., Hernandez, H., Watson, J., Ways, K., Cooper, D. R., and Farese, R. V.** (1992) Effects of insulin on diacylglycerol/protein kinase-C signalling and glucose transport in rat skeletal muscle in vivo and in vitro *Endocrinology* 130, 3345-3355
182. **Russ, M., and Eckel, J.** (1995) Insulin action on cardiac glucose transport: studies on the role of protein kinase C. *Biochim. Biophys. Acta* 1265, 73/78
183. **Hoffman, J. M., Ishizuka, T., and Farese, R. V.** (1991) Interrelated effects of insulin and glucose on diacylglycerol-protein kinase-C signalling in rat adipocytes and solei muscle in vitro and in vivo in diabetic rats. *Endocrinology* 128, 2937-2948
184. **Sowell, M. O., Treutelaar, M. K., Burant, C. F., and Buse, M. G.** (1988) Minimal effects of phorbol esters on glucose transport and insulin sensitivity of rat skeletal muscle *Diabetes* 37, 499-506
185. **Tsakiridis, T., Vranic, M., and Klip, A.** (1994) Disassembly of the actin network inhibits insulin-dependent stimulation of glucose-transport and prevents recruitment of glucose transporters to the plasma membrane *J. Biol. Chem.* 269(47), 29934-29942
186. **Davey, H. W., and Wildeman, A. G.** (1995) Molecular analysis of bovine actin gene and pseudogene sequences: expression of nonmuscle and striated muscle isoforms in adult tissues. *DNA Cell Biol.* 14, 555-63
187. **Alberts, B., Bray, D., Lewis, J., Raff, M., Roberts, K., and Watson, J. D.** (1989) *Molecular biology of the cell*, Second Ed., Garland Publishing, Inc., New York & London
188. **Cooper, J. A.** (1987) Effects of cytochalasins and phalloidin on actin. *J. Cell Biol.* 105, 1473-1478
189. **Ohmori, H., Toyama, S., and Toyama, S.** (1992) Direct proof that the primary site of action of cytochalasin on cell motility processes is actin. *J. Cell Biol.* 116(4), 933-941
190. **Ridley, A. J., and Hall A.** (1992) The small GTP-binding protein rho regulates assembly of focal adhesions and actin stress fibers in response to growth factors. *Cell*, 70, 389-399
191. **Ridley, A. J., Paterson, H. F., Johnston, C. L., Diekmann D., and A., H.** (1992) The small GTP-binding protein rac regulates growth factor-induced membrane ruffling. *Cell* 70, 401-410
192. **Kuznetsov, S., Langford, G.M., and Weiss, D.G.** (1992) Actin-dependent organelle movement in squid axoplasm. *Nature* 356(23), 722-725
193. **Gottlieb, T. A., Ivanov, I.E., Adensik, M., and Sabatini, D.** (1993) Actin microfilaments play a critical role in endocytosis at the apical but not the basolateral surface of polarized epithelial cells. *J. Cell Biol.* 120(13), 695-710

194. **Hirokawa, N., Sobue, K., Kanda, K., Harada, A., and Yorifuji, H.** (1989) The cytoskeletal architecture of the presynaptic terminal and molecular structure of synapsin I. *J. Cell Biol.* 108, 111-126
195. **Christensen, H.** (1990) Role of amino acid transport and countertransport in nutrition and metabolism. *Physiol. Rev.* 70, 43-77
196. **Maroni, B. J., Karapanos, G., and Mitch, W. E.** (1986) System ASC and sodium-independent neutral amino acid transport in muscle of uremic rats. *Am. J. Physiol.* 251, F81-F86
197. **Arriza, J. L., Kavanaugh, M. P., Fairman, W. A., Wu, Y. N., Murdoch, G. H., North, R. A., and Amara, S. G.** (1993) Cloning and expression of a human neutral amino acid transporter with structural similarity to the glutamate transporter gene family. *J. Biol. Chem.* 268, 15329-15332
198. **Tate, S., Yan, N., and Udenfriend, S.** (1992) Expression cloning of a Na⁺-independent neutral amino acid transporter from rat kidney. *Proc. Natl. Acad. Sci. USA* 89, 1-5
199. **Tadros, L. B., Taylor, P. M., and Rennie, M. J.** (1993) Characteristics of glutamine transport in primary tissue culture of rat skeletal muscle. *Am. J. Physiol.* 265, E135-E144
200. **Kim, J., Closs, E., Albritton, L., and Cunningham, J.** (1991) Transport of cationic amino acids by the mouse ecotropic retrovirus receptor. *Nature* 352, 725-728
201. **Wang, H., Kavanaugh, M., North, R., and Kabat, D.** (1991) Cell-surface receptor for ecotropic murine retroviruses is a basic amino acid transporter. *Nature* 352, 729-731
202. **Betran, J., Werner, A., Moore, M., Stange, G., Markovich, D., Biber, J., Testar, X., Zorzano, A., Palacin, M., and Murer, H.** (1992) Expression cloning of a cDNA from rabbit kidney cortex that induces a single transport system for cystine and dibasic and neutral amino acids. *Proc. Natl Acad Sci USA* 89, 5601-5605
203. **Mendiaz, E., Mamounas, M., Moffett, J., and Englesberg, E.** (1986) A defined medium for the effect of insulin on the growth, amino acid transport and morphology of chinese hamster ovary cells, CHO-K1 (CCL 61) and the isolation of insulin "independent" mutants. *In vitro Cell. Dev. Biol.* 22, 66-74
204. **Kaplowitz, P. B.** (1987) Glucocorticoids enhance somatomedin-C binding and stimulation of amino acid uptake in human fibroblasts. *J. Clin. Endocrinol. & Metab.* 64, 563-571
205. **Logan, W. J., Klip, A., and Galagang, E.** (1982) Regulation of amino acid transport in L6 muscle cells: I. Stimulation of transport system A by amino acid deprivation. *J. Cell. Physiol.* 112, 229-236
206. **Villereal, M. L., and Cook, J. S.** (1978) Regulation of active amino acid transport by growth-related changes in membrane potential in a human fibroblast. *J. Biol. Chem.* 253, 8257-8262
207. **Leister, K. J., Schenerman, M. A., and Racker, E. J.** (1988) Energetic mechanism of system A amino acid transport in normal and transformed mouse fibroblasts. *J. Cell. Physiol.* 135, 163-168
208. **Goldstein, R. H., Sakowski, S., Meeker, D., Franzblau, C., and Polgar, P.** (1986) The effect of prostaglandin E2 (PGE2) on amino acid uptake and protein formation by lung fibroblasts. *J. Biol. Chem.* 261, 8734-8737

209. **Krupsky, M., Fine, A., Berk, J. L., and Goldstein, R. H.** (1993) The effect of retinoic acid on amino acid uptake and protein synthesis by lung fibroblasts. *J. Biol. Chem.* 268, 23283-23288
210. **Guma, A., Testar, X., Palacin, M., and Zorzano, A.** (1988) Insulin-stimulated α -(methyl)aminoisobutyric acid uptake in skeletal muscle. *Biochem. J.* 253, 625-629
211. **Hundal, H. S., Bilan, P. J., Tsakiridis, T., Marette, A., and Klip, A.** (1994) Structural disruption of the trans-Golgi network does not interfere with the acute stimulation of glucose and amino acid uptake by insulin-like growth factor I in muscle cells. *Biochem. J.* 297, 289-295
212. **Cariappa, R., and Kilberg, M. S.** (1990) Hormone-induced system A amino acid transport activity in rat liver plasma membrane and golgi vesicles. *J. Biol. Chem.* 265, 1470-1475
213. **Klip, A., Logan, W. J., and Galagang, E.** (1982) Regulation of amino acid transport in L6 myoblasts. II. Different chemical properties of transport after amino acid deprivation. *J. Cell. Physiol.* 113, 56-66
214. **Kilberg, M. S., Hutson, R. G., and Laine, R. O.** (1994) Amino acid-regulated gene expression in eucaryotic cells. *FASEB J.* 8, 13-19
215. **McGivan, J. D., and Pastor-Anglada, M.** (1994) Regulatory and molecular aspects of mammalian amino acid transport. *Biochem. J.* 299, 321-334
216. **Englesberg, E., and Moffett, J.** (1986) A genetic approach to the study of neutral amino acid transport in mammalian cells in culture. *J. Membr. Biol.* 91, 199-212
217. **Kilberg, M. S., Handlogten, M. E., and Christensen, H. N.** (1980) Characteristics of an amino acid transport system in rat liver for glutamine, asparagine, histidine and closely related analogs. *J. Biol. Chem.* 255, 4011-4019
218. **McDowell, H. E., Christie, G. R., Stenhouse, G., and Hundal, H. S.** (1995) Leucine activates system A amino acid transport in L6 rat skeletal muscle cells. *Am. J. Physiol.* 269, C1287-C1294
219. **Yaffe, D.** (1968) Retention of differentiation potentialities during prolonged cultivation of myogenic cells. *Proc. Natl. Acad. Sci. U.S.A.* 61, 477-483
220. **Klip, A., Li, G., and Logan, W. J.** (1984) Induction of sugar uptake response to insulin by serum depletion in fusing L6 myotubes. *Am. J. Physiol.* 247, E494-E499
221. **Heino, J., and Massague, J.** (1990) Cell adhesion to collagen and decreased myogenic gene expression implicated in the control of myogenesis by transforming growth factor β . *J. Biol. Chem.* 265, 10181-10184
222. **Kidokoro, Y.** (1975) Developmental changes of membrane electrical properties in a rat skeletal muscle cell line. *J. Physiol.* 244, 129-143
223. **Shainberg, A., Yagil, G., and Yaffe, D.** (1971) Alteration of enzymatic activities during muscle differentiation in vitro. *Dev. Biol.* 25, 1-29
224. **Wright, W. E., Sassoon, D. A., and Lin, V. K.** (1989) Myogenin, a factor regulating myogenesis, has a domain homologous to myoD. *Cell* 56, 607-617
225. **Bischoff, R., and Holtzer, H.** (1969) Mitosis and the process of differentiation of myogenic cells in vitro. *J. Cell. Biol.* 41, 188-200
226. **Mitsumoto, Y., Burdett, E., Grant, A., and Klip, A.** (1991) Differential expression of the GLUT1 and GLUT4 glucose transporters during differentiation of L6 muscle cells. *Biochem. Biophys. Res. Comm.* 175(2), 652-659
227. **Klip, A., Li, G., and Walker, D.** (1983) Insulin binding to differentiating muscle cells in culture. *Can. J. Biochem. Cell Biol.* 61, 644-649

228. **Beguino, F., Kahn, C. R., Moses, A. C., and Smith, R. J.** (1986) The development of insulin receptors and responsiveness is an early marker of differentiation in the muscle cell line L6. *Endocrinology* 118, 446-455
229. **Beguino, F., Kahn, C. R., Moses, A. C., and Smith, R. J.** (1985) Distinct biologically active receptors for insulin, insulin-like growth factor I and insulin-like growth factor II in cultured skeletal muscle cells. *J. Biol. Chem.* 260
230. **Bilan, P., Mitsumoto, Y., Maher, F., Simpon, I., and Klip, A.** (1992) Detection of the GLUT3 facilitative glucose transporter in rat L6 muscle cells: Regulation by cellular differentiation, insulin and insulin-like growth factor-I. *Biochem. Biophys. Res. Comm.* 186(2), 1129-1137
231. **Bilan, P. J., Mitsumoto, Y., Ramlal, T., and Klip, A.** (1992) Acute and long-term effects of insulin-like growth factor I on glucose transporters in muscle cells. *FEBS* 10769, 298, 285-290
232. **Goodyear, L. J., King, P. A., Hirshman, M. F., Thompson, C. M., Horton, E. D., and Horton, E. S.** (1990) Contractile activity increases plasma membrane glucose transporters in absence of insulin. *Am. J. Physiol.* 258, E667-E672
233. **Lee, A., Hansen, P. A., and Holloszy, J. O.** (1995) Wortmannin inhibits insulin-stimulated but not contraction-stimulated glucose transport activity in skeletal muscle. *FEBS Lett.* 361, 51-54
234. **Group, N. D. D.** (1979) Classification and diagnosis of diabetes mellitus and other categories of glucose intolerance. *Diabetes* 28, 1039-1057
235. **Flier, J. S.** (1992) Lilly Lecture: Syndromes of insulin resistance. From patient to gene and back again. *Diabetes* 41, 1207-1219
236. **DeFronzo, R. A., Ferrannini, E., and Koivisto, V.** (1983) New concepts in the pathogenesis and treatment of non-insulin-dependent diabetes mellitus *Am. J. Med.* 75, 52-81
237. **Kolterman, O. G., Gray, R. S., Griffin, J., Burstein, P., Insel, J., Scarlett, J. A., and Olefsky, J. M.** (1981) Receptor and postreceptor defects contribute to the insulin resistance in noninsulin-dependent diabetes mellitus *J. Clin. Invest.* 68, 957-969
238. **Taylor, S. I., Kadowaki, T., Accili, D., Cama, A., and McKeon, C.** (1990) Mutations in insulin-receptor gene in insulin-resistant patients. *Diabetes care* 13, 257-279
239. **Taylor, R.** (1991) Insulin action 1991 *Clin. Endo* 34, 159-171
240. **Taylor, S. I.** (1992) Lilly Lecture: Molecular mechanisms of insulin resistance: lessons from patients with mutations in the insulin receptor gene. *Diabetes* 41, 1473-1490
241. **Almind, K., Bjorbaek, C., Vestergaard, H., Hansen, T., Echwald, S., and Pedersen, O.** (1993) Amino acid polymorphisms in the insulin receptor substrate IRS-1 in late onset noninsulin-dependent diabetes mellitus. *Lancet* 342, 828-832
242. **Taberner, P. V., and Connelly, D. M.** (1991) Reduced insulin binding to liver plasma membranes in inherently obese diabetic CBA/CA mice. *Biochem. Pharm.* 41, 729-733
243. **LeMarchand-Brustel Y., Gremeaux, T., Ballotti, R., and Van, O. E.** (1985) Insulin receptor tyrosine kinase is defective in skeletal muscle of insulin-resistant obese mice. *Nature* 315, 676-678

244. **Saad, M. J. A., Araki, E., Miralpeix, M., Rothenberg, P. L., White, M. F., and Kahn, C. R.** (1992) Regulation of insulin receptor substrate 1 in liver and muscle of animal models of insulin resistance. *J. Clin. Invest.* 90, 1839-1849
245. **Friedenberg, G. R., Reichart, D. R., Olefsky, J. M., and Henry, R. R.** (1988) Reversibility of defective adipocyte insulin receptor kinase activity in non-insulin-dependent diabetes mellitus: effects of weight loss. *J. Clin. Invest.* 82, 1398-1406
246. **Rothman, D. L., Shulman, R. G., and Shulman, G. I.** (1992) ³¹P nuclear magnetic resonance measurements of muscle glucose-6-phosphatase: evidence for reduced insulin-dependent muscle glucose transport or phosphorylation activity in non-insulin-dependent diabetes mellitus. *J. Clin. Invest.* 89, 1069-1075
247. **Gerich, J.** (1989) Oral hypoglycemic agents. *New England journal of Medicine.* 321(18), 1231-45
248. **Groop, L. C.** (1992) Sulfonylureas in NIDDM. *Diabetes Care* 15, 737-754
249. **Meyer, F., Ipaktchi, M., and Clauser, H.** (1967) Specific inhibition of gluconeogenesis by biguanides. *Nature* 213, 203-204
250. **Klip, A., and Leiter, L. A.** (1990) Cellular mechanism of action of metformin. *Diabetes Care* 13, 696-704
251. **Hother-Nielsen, O., Schmitz, O., Andersen, P. H., Beck-Nielsen, H., and Pedersen, O.** (1989) Metformin improves peripheral but not hepatic insulin action in obese patients with type II diabetes. *Acta Endocrinol.* 120, 257-265
252. **Klip, A., Guma, A., Ramlal, T., Bilan, P. J., Lam, L., and Leiter, L. A.** (1992) Stimulation of hexose transport by metformin in L6 muscle cells. *Endocrinology* 130, 2535-2544
253. **Momose, Y., Meguro, K., Ikeda, H., Hatanaka, C., Oi, S., and Sohda, T.** (1991) Studies on antidiabetic agents. Synthesis and biological activities of pioglitazone and related compounds. *Chem. Pharm. Bull.* 39(6), 1440-1445
254. **Suter, S. L., Nolan, J. J., Wallace, P., Gumbiner, B., and Olefsky, J. M.** (1992) Metabolic effects of new oral hypoglycemic agent CS-045 in NIDDM subjects. *Diabetes Care* 15, 193-203
255. **Nolan, J. J., Ludvik, B., Beerdsen, P., Joyce, M., and Olefsky, J.** (1994) Improvement in glucose tolerance and insulin resistance in obese subjects treated with troglitazone. *N. Engl. J. Med.* 331, 1188-1193
256. **Ciaraldi, T. P., Huber-Knudsen, K., Hickman, M., and Olefsky, J. M.** (1995) Regulation of glucose transport in cultured muscle cells by novel hypoglycemic agents. *Metabolism* 44, 976-982
257. **Lee, M.-K., and Olefsky, J. M.** (1995) Acute effects of troglitazone on in vivo insulin action in normal rats. *Metabolism* 44, 1166-1169
258. **Lehmann, J. M., Moore, L. B., Smith-oliver, T. A., Wilkison, W. O., Willson, T. M., and Kliewer, S. A.** (1995) An antidiabetic thiazolidinedione is a high affinity ligand for peroxisome proliferator-activated receptor γ (PPAR γ). *J. Biol. Chem.* 270, 12953-12956
259. **Khoursheed, M., Miles, P. D. G., Gao, K.-M., Lee, M.-K., Moossa, A. R., and Olefsky, J. M.** (1995) Metabolic effects of troglitazone on fat-induced insulin resistance in the rat. *Metabolism* 44, 1489-1494
260. **Loubatieres, A.** (1944) Relations entre la structure moleculaire et l'activate hypoglycemiante des aminosulfamides hypoglycemiants. *Arch. Int. Physiol.* 54, 174-177

261. **University, G. D. P.** (1976) A study of the effects of hypoglycemia agents on vascular complications in patients with adult-onset diabetes. VI. Supplementary report on nonfatal events in patients treated with tolbutamide. *Diabetes* 25, 1129-1153
262. **Panten, U., Schwanstecher, M., and Schwanstecher, C.** (1992) Pancreatic and extrapancreatic sulfonylurea receptors. *Horm. Metab. Res.* 24, 549-554
263. **Krall, L. P.** (1991) The treatment of NIDDM in the decade of the 90s. *Diabetes Res. Clin. Pract.* 14 suppl 2, S15-S20
264. **Loubatieres, A.** (1957) The hypoglycemic sulfonamides: history and development of the problem from 1942 to 1945. *Ann. NY Acad. Sci.* 71, 4-11
265. **Malaisse, W. J., Mahy, M., Brisson, G. R., and Malaisse-Lagae, F.** (1972) The stimulus-secretion coupling of glucose-induced insulin release. VIII. Combined effects of glucose and sulfonylureas. *Eur. J. Clin. Invest.* 2, 85-90
266. **Grodsky, G. M., Epstein, G. H., Fanska, R., and Karam, J. H.** (1977) Pancreatic actions of sulfonylureas. *Fed. Proc.* 36, 2714-2719
267. **Groop, L., Luzi, L., Melander, A., Groop, P.-H., Ratheiser, K., Simonson, D., and De-Fronzo, R.** (1987) Different effects of glyburide and glipizide on insulin secretion and hepatic glucose production in normal and NIDDM subjects. *Diabetes* 36, 1320-1328
268. **Masaki, Y., Tanigawa, K., Ohguni, S., Tsuchiyama, S., and Note, S.** (1986) The effect of a hypoglycemic sulfonylurea on insulin release from isolated rat pancreatic islets. *Shimano J. Med. Sci.* 10, 1-8
269. **Groop, L. C., Barzilai, N., Ratheiser, K., Luzi, L., Wahlin-Boll, E., Melander, A., and DeFronzo, R. A.** (1991) Dose-dependent effects of glyburide on insulin secretion and glucose uptake in humans. *Diabetes Care* 14(8), 724-27
270. **Pedersen, O., Bak, J. F., Andersen, P. H., Lund, S., Moller, D. E., Flier, J. S., and Kahn, B. B.** (1990) Evidence against altered expression of GLUT1 or GLUT4 in skeletal muscle of patients with obesity or NIDDM. *Diabetes* 39(7), 865-70
271. **Kolterman, O., Gray, R., Shapiro, G., Scarlett, J., Griffin, J., and Olefsky, J.** (1984) The acute and chronic effects of sulfonylurea therapy in type II diabetic subjects. *Diabetes* 33(4), 346-54
272. **Simonson, D. C., Ferrannini, E., Bevilacqua, S., Smith, D., Barrett, E., Carlson, R., and DeFronzo, R. A.** (1984) Mechanism of improvement in glucose metabolism after chronic glyburide therapy. *Diabetes* 33(838-845)
273. **Van Haeften, T., Veneman, T., Gerich, J., and Van der Veen, E.** (1991) Influence of gliclazide on glucose-stimulated insulin release in man. *Metabolism* 40, 751-55
274. **Eriksson, J., Franssila-Kallunki, A., Ekstrand, A., Saloranta, C., Widen, E., Schalin, C., and Groop, L.** (1989) Early metabolic defects in persons at increased risk for non-insulin dependent diabetes mellitus. *N. Engl. J. Med.* 321, 337-343
275. **Shapiro, E. T., van cauter, E., Tillil, H., Given, B. D., Hirsch, L., Beebe, C., Rubenstein, A. H., and Polonsky, K. S.** (1989) Glyburide enhances the responsiveness of the b-cell to glucose but does not correct the abnormal patterns of insulin secretion in noninsulin-dependent diabetes mellitus. *J. Clin. Endocrinol. Metab.* 69, 571-576
276. **Hosker, J. P., Rudeski, A. S., Burnett, M. A., Matthews, D. R., and Turner, R. C.** (1989) Similar reduction of first and second-phase B-cell responses at

- three different glucose levels in type II diabetes and the effect of gliclazide therapy. *Metabolism* 38, 767-72
277. **Duckworth, W. C., Solomon, S. S., and Kitabchi, A. E.** (1972) Effect of chronic sulfonylurea therapy on plasma insulin and proinsulin levels. *J. Clin. Endocrinol. Metab.* 35, 585-591
278. **Lebovitz, H.** (1984) Cellular loci of sulfonylurea actions. *Diabetes Care.* 7(suppl 1), 67-71
279. **Beck-Neilsen, H., Pedersen, O., and Lindskov, H. O.** (1979) Increased insulin sensitivity and cellular insulin binding in obese diabetics following treatment with glibenclamide. *Acta Endocrinol.* 90, 451-462
280. **Rossetti, L., Smith, D., Shulman, G. I., Papachristou, D., and DeFronzo, R. A.** (1987) Correction of hyperglycemia with phlorizin normalizes tissue sensitivity to insulin in diabetic rats *J. Clin. Invest.* 79, 1510-1515
281. **Kajinuma, H., Kuzyua, T., and Ide, T.** (1974) Effects of hypoglycemic sulfonamides on glucagon and insulin secretion in ducks and dogs. *Diabetes* 23, 412-417
282. **Ostenson, C., Nysten, A., Grill, V., Gutniak, M., and Efendic, S.** (1986) Sulfonylurea-induced inhibition of glucagon secretion from the perfused rat pancreas: evidence for a direct, nonparacrine effect. *Diabetologia* 29, 861-867
283. **Tsalikian, E., Dunphy, T. W., Bohannon, N. V., Lorenzi, M., Gerich, J. E., Forsham, P. H., Kane, J. P., and Karam, J. H.** (1977) The effect of chronic oral antidiabetic therapy on insulin and glucagon responses to a meal. *Diabetes* 26, 314-321
284. **Pek, S., Fajans, S., Floyd, J., Knopf, R., and Conn, J.** (1972) Failure of sulfonylureas to suppress plasma glucagon in man. *Diabetes* 21, 216-223
285. **Efendic, S., Enzmann, F., Nysten, A., Uvnas-Wallensten, K., and Luft, R.** (1979) Effect of glucose/sulfonylurea interaction on release of insulin, glucagon and somatostatin from isolated perfused rat pancreas. *Proc. Natl. Acad. Sci. USA* 76, 5901-5904
286. **Olefsky, J. M., and Reaven, G. M.** (1976) Effects of sulfonylurea therapy on insulin binding to mononuclear leukocytes of diabetic patients. *Am. J. Med.* 60, 89-95
287. **Hirshman, M. F., and Horton, E. S.** (1990) Glyburide increases insulin sensitivity and responsiveness in peripheral tissues of the rat as determined by the glucose clamp technique. *Endocrinology* 126, 2407-2412
288. **Faber, O. K., Beck-Nielsen, H., Binder, C., Butzer, P., Damsgaard, E. M., Froland, F., Hjollund, E., Lindskov, H. O., Melander, A., Pedersen, O., Petersen, P., Schwartz Sorensen, N., and Wahlin-Boll, E.** (1990) Acute actions of sulfonylurea drugs during long-term treatment of NIDDM. *Diabetes care* 13, 26-31
289. **Wang, P. H., Beguinot, F., and Smith, R. J.** (1987) Augmentation of the effects of insulin and insulin-like growth factors I and II on glucose uptake in cultured rat skeletal muscle cells by sulfonylureas. *Diabetologia* 30, 797-803
290. **Van Putten, J. P. M., and Krans, H. M. J.** (1986) Characterization of the sulfonylurea-induced potentiation of the insulin response in cultured 3T3 adipocytes. *Biochem. Pharm.* 35, 2141-2144
291. **Wang, P. H., Moller, D., Flier, J. S., Nayak, R. C., and Smith, R. J.** (1989) Coordinate regulation of glucose transporter function, number, and gene expression by insulin and sulfonylureas in L6 rat skeletal muscle cells *J. Clin. Invest.* 84(1), 62-7

292. **Jacobs, D., and Jung, C.** (1985) Sulfonylurea potentiates insulin-induced recruitment of glucose transport carrier in rat adipocytes. *J.Biol.Chem.* 260(5), 2593-2596
293. **Cooper, D. R., Vila, M. C., watson, J., Nair, G., Pollet, R. J., Standaert, M., and Farese , R. V.** (1990) Sulfonylurea-stimulated glucose transport association with diacylglycerol like activation of protein kinase C in BC3H1 myocytes. *Diabetes* 39, 1399-1407
294. **Rogers, B. J., Standaert, M. L., and Pollet, R. J.** (1987) Direct effects of sulfonylurea agents on glucose transport in the BC3H1 myocyte. *Diabetes* 36, 1292-1296
295. **Davidson, M. B., Molnar, I. G., Furman, A., and Yamaguchi, D.** (1991) Glyburide-stimulated glucose transport in cultured muscle cells via protein kinase C-mediated pathway requiring new protein synthesis. *Diabetes* 40, 1531-1538
296. **Gorray, K., Maimon, J., and Schneider, B.** (1990) Studies of antiproteolytic effects of glyburide on rat L6 myoblasts; Comparisons with insulin. *Metabolism* 39(2), 109-116
297. **Tordjman, K. M., Leingang, K. A., James, D. E., and Mueckler, M. M.** (1989) Differential regulation of two distinct glucose transporter species expressed in 3T3-L1 adipocytes: effect of chronic insulin and tolbutamide treatment *Proc. Natl. Acad. Sci. U.S.A.* 86(20), 7761-5
298. **Zuber, M., Wang, S., Thammavaram, K., Reed, D., and Reed, B.** (1985) Elevation of the number of cell-surface insulin receptors and the rate of 2-deoxyglucose uptake by exposure of 3T3-L1 adipocytes to tolbutamide. *J. Biol. Chem.* 260(26), 14045-14052
299. **Farese, R. V., Ishizuka, T., Standaert, M. L., and Cooper, D. R.** (1991) Sulfonylureas activate glucose transport and protein kinase C in rat adipocytes. *Metabolism* 40(2), 196-200
300. **Maloff, B., and Lockwood, D.** (1981) In vitro effects of a sulfonylurea on insulin action in adipocytes. Potentiation of insulin-stimulated hexose transport. *J. Clin. Invest.* 68, 85-90
301. **Martz, A., Jo, I., and Jung, C. Y.** (1989) Sulfonylurea binding to adipocyte membranes and potentiation of insulin-stimulated hexose transport *J. Biol. Chem.* 264(23), 13672-8
302. **Jacobs, D. B., Hayes, G. R., and Lockwood, D. H.** (1989) In vitro effects of sulfonylurea on glucose transport and translocation of glucose transporters in adipocytes from streptozocin-induced diabetic rats *Diabetes* 38(2), 205-11
303. **Bak, J. F., Schmitz, O., Schwartz Sorensen, N., and Pedersen, O.** (1989) Postreceptor effects of sulfonylurea on skeletal muscle glycogen synthase activity in type II diabetic patients. *Diabetes* 38, 1343-1348
304. **Putnam, W. S., Andersen, D. K., Jones, R. S., and Lebovitz, H. E.** (1981) Selective potentiation of insulin-mediated glucose disposal in normal dogs by the sulfonylurea, glipizide. *J. Clin. Invest.* 67, 1016-1023
305. **Mandarino, L., and Gerich, J.** (1984) Prolonged sulfonylurea administration decreases insulin resistance and increases insulin secretion in non-insulin-dependent diabetes mellitus; evidence for improved insulin action at a postreceptor site in hepatic as well as extrahepatic tissues. *Diabetes Care* 7 suppl 1, 89-99

306. **Tormo, M. A., Zubeldia, M. A., Montero, J. L., and Campillo, J. E.** (1989) Gliclazide increases glucose utilisation by rat intestine in vitro. *Diabete Metabol.* 15, 170-175
307. **Campbell, D. B., Lavielle, R., and Nathan, C.** (1991) The mode of action and clinical pharmacology of gliclazide: a review. *Diabetes Research and Clinical Practice.* 14, S21-S36
308. **Dettori, A. G.** (1980) Antiplatelet effects of long-term treatment of diabetic patients with gliclazide. In: Keen et al. (Eds). *Gliclazide and the Treatment of Diabetes.* International Congress and Symposium Series No 20. Proceedings of International Symposium, London, April 5-6, 1979. Academic Press and Royal Society of Medicine. , 189-193
309. **Schmid-Antomarchi, H., De Weille, J., Fosset, M., and Lazdunski, M.** (1987) The receptor for antidiabetic Sulfonylureas controls the activity of the ATP-modulated K⁺ channel in insulin-secreting cells. *J. Biol. Chem.* 262(33), 15840-15844
310. **Gaines, K. L., Hamilton, S., and Boyd III, A. E.** (1988) Characterization of the sulfonylurea receptor on beta cell membranes. *J. Biol. Chem.* 263(25), 2589-2592
311. **Aguilar-Bryan, L., Nelson, D. A., Vu, Q. A., Humphrey, M. B., and Boyd III, A. E.** (1990) Photoaffinity labeling and partial purification of the B cell sulfonylurea receptor using a novel, biologically active glyburide analog. *J. Biol. Chem.* 265, 8218-8224
312. **Boyd III, A. E.** (1988) Sulfonylurea receptors, ion channels, and fruit flies. *Diabetes* 37, 847-50
313. **Takano, M., and Noma, A.** (1993) The ATP-sensitive K⁺ channel. *Progress in Neurobiol.* 41, 21-30
314. **Allard, B., and Lazdunski, M.** (1993) Pharmacological properties of ATP-sensitive K⁺ channels in mammalian skeletal muscle cells. *Eur. J. Pharmacol.* 236, 419-426
315. **Fosset, M., De Weille, J., Green, R. D., Schmid-Antomarchi, H., and Lazdunski, M.** (1988) Antidiabetic sulfonylureas control action potential properties in heart cells via high affinity receptors that are linked to ATP-dependent K⁺ channels. *J. Biol. Chem.* 263, 7933-7936
316. **Noma, A.** (1983) ATP-regulated K⁺ channels in cardiac muscle. *Nature* 305, 147-148
317. **Castle, N., and Heylett, D.** (1987) Effect of channel blockers on potassium efflux from metabolically exhausted frog skeletal muscle. *J. Physiol.* 383, 31-43
318. **Standen, N. B., Pettit, A. I., Davies, N. W., and Stanfield, P. R.** (1992) Activation of ATP-dependent K⁺ currents in intact skeletal muscle fibres by reduced intracellular pH. *Proc. R. Soc. Lond. B. Biol. Sci.* 247, 195-198
319. **Woll, K. H., Lonnendonker, U., and Neumcke, B.** (1989) ATP-sensitive potassium channels in adult mouse skeletal muscle: different modes of blockage by internal cations, ATP and tolbutamide. *Eur. J. Physiol.* 414, 622-628
320. **Quasthoff, S., Franke, C., Hatt, H., and Richter-Turtur, M.** (1990) Two different types of potassium channels in human skeletal muscle activated by potassium channel openers. *Neuroscience Letters* 119, 191-194
321. **Rajan, A. S., Luo, Z. T., Kahn, B. B., Comstock, J. P., Cushman, S. W., and Boyd, A. E. r.** (1994) Do adipocytes contain high affinity sulfonylurea receptors? *Endocrinology* 134, 1581-1588
322. **Aguilar-Bryan, L., Nichols, C. G., Wechsler, S. W., Clement IV, J. P., Boyd III, A. E., Gonzalez, G., Herrera-Sosa, H., Nguy, K., Bryan, J.,**

- and Nelson, D. A.** (1995) Cloning of the b cell high affinity sulfonylurea receptor: A regulator of insulin secretion. *Science* 268, 423-426
323. **Thomas, P. M., Cote, G. J., Wohlk, N., Haddad, B., Mathew, P. M., Rabl, W., Aguilar-Bryan, L., Gagel, R. F., and Bryan, J.** (1995) Mutations in the sulfonylurea receptor gene in familial persistent hyperinsulinemic hypoglycemia of infancy. *Science* 268, 426-429
324. **Ammala, G., Moorhouse, A., Gribble, F., Ashfield, R., Proks, P., Smith, P. A., Sakura, H., Coles, B., Ashcroft, S. J. H., and Ashcroft, F. M.** (1996) Promiscuous coupling between the sulfonylurea receptor and inwardly rectifying potassium channels. *Nature* 379, 545-548
325. **Feinglos, N., and Lebovitz, H.** (1978) Sulfonylureas increase the number of insulin receptors. *Nature* 276, 184-185
326. **Grunberger, G., Ryan, J., and Gorden, P.** (1982) Sulfonylureas do not affect insulin binding or glycemic control in insulin-dependent diabetics. *Diabetes* 32, 398-402
327. **Firth, R. G., Bell, P. M., and Rizza, R. A.** (1986) Effects of tolazamide and exogenous insulin on insulin action in patients with non-insulin-dependent diabetes mellitus. *N. Engl. J. Med.* 314, 1280-1286
328. **Bak, J. F., and Pedersen, O.** (1991) Gliclazide and insulin action in human muscle. 114, S61-S64
329. **Pedersen, O., Hother-Nielsen, O., Bak, J. F., Hjollund, E., and Beck-Nielsen, H.** (1991) Effects of sulfonylureas on adipocyte and skeletal muscle insulin action in patients with non-insulin-dependent diabetes mellitus. *Am. J. Med.* 90(suppl 6A), 22S-28S
330. **Jacobs, D. B., Hayes, G. R., and Lockwood, D. H.** (1987) Effect of chlorpropamide on glucose transport in rat adipocytes in the absence of changes in insulin binding and receptor-associated tyrosine kinase activity. *Metabolism* 36(6), 548-554
331. **Kern, M., Loomis, T., Tapscott, E., and Dohm, G.** (1993) Increased muscle glucose uptake in response to chronic glyburide treatment is not related to changes in glucose transporter (GLUT4) protein. *Int. J. Biochem.* 25(9), 1257-1261
332. **Muller, G., and Wied, S.** (1993) The sulfonylurea drug, glimepiride, stimulates glucose transport, glucose transporter translocation, and dephosphorylation in insulin-resistant rat adipocytes in vitro. *Diabetes* 42, 1852-1867
333. **Muller, G., Wied, S., Wetekam, E. M., Crecelius, A., Unkelbach, A., and Punter, J.** (1994) Stimulation of glucose utilization in 3T3 adipocytes and rat diaphragm in vitro by the sulphonylureas, glimepiride and glibenclamide, is correlated with modulations of the cAMP regulatory cascade. *Bioch. pharm* 48, 985-996
334. **Walker, P. S., Ramlal, T., Sarabia, V., Koivisto, U. M., Bilan, P. J., Pessin, J. E., and Klip, A.** (1990) Glucose transport activity in L6 muscle cells is regulated by the coordinate control of subcellular glucose transporter distribution, biosynthesis, and mRNA transcription. *J. Biol. Chem.* 265(3), 1516-23
335. **Smith, P., Krohn, R., Hermanson, G., Mallia, A., Gartner, F., Provenzano, M., Fujimoto, E., Goeke, N., Olsen, B., and Klenk, D.** (1985) Measurement of protein using bicinchoninic acid. *Anal. Biochem.* 150, 76-85
336. **Galderhead, D. M., Kitagawa, K., Tanner, L. I., Holman, G. D., and Lienhard, G. E.** (1990) Insulin regulation of the two glucose transporters in 3T3-L1 adipocytes. *J. Biol. Chem.* 265, 13800-13807

337. **Vestergaard, H., Weinreb, J. E., Rosen, A. S., Bjorbaek, C., Hansen, L., Pedersen, O., and Kahn, B. B.** (1995) Sulfonylurea therapy improves glucose disposal without changing skeletal muscle GLUT4 levels in noninsulin-dependent diabetes mellitus subjects: a longitudinal study. *J. Clin. Endocrinol. Metab.* 80, 270-275
338. **Sargeant, R. J., and Paquet, M. R.** (1993) Effect of insulin on the rates of synthesis and degradation of GLUT1 and GLUT4 glucose transporters in 3T3-L1 adipocytes *Biochem. J.* 290, 913-919
339. **Sargeant, R., Mitsumoto, Y., Sarabia, V., Shillabeer, G., and Klip, A.** (1993) Hormonal regulation of glucose transporters in muscle cells in culture. *J. Endocrinol. Invest.* 16, 147-162
340. **Klip, A., Ramlal, T., Bilan, P. J., Marette, A., Liu, Z., and Mitsumoto, Y.** (1993) What signals are involved in the stimulation of glucose transport by insulin in muscle cells? *Cell Signal.* 5, 519-529
341. **Dunne, M. J., Aspinall, R. J., and Petersen, O. H.** (1990) The effects of cromakalim on ATP-sensitive potassium channels in insulin-secreting cells. *Br. J. Pharmacol.* 99(1), 169-175
342. **Sanguinetti, M., Scott, A., Zingaro, G., and Siegl, P.** (1988) BRL 34915 (cromakalim) activates ATP-sensitive K⁺ current in cardiac muscle. *Proc. Natl. Acad. Sci.* 85, 8360-8364
343. **Hundal, H. S., Ramlal, T., Reyes, R., Leiter, L. A., and Klip, A.** (1992) Cellular mechanism of metformin action involves glucose transporter translocation from an intracellular pool to the plasma membrane in L6 muscle cells. *Endocrinology*
344. **Nechay, B. R.** (1984) Mechanism of action of vanadium. *Annu. Rev. Pharmacol. Toxicol.* 24, 501-524
345. **Nechay, B. R., Nanninga, L. B., Nechay, P. S. E., Post, R. L., Grantham, J. J., Macara, I. G., Kubena, L. F., Phillips, T. D., and Nielsen, F. H.** (1986) Role of vanadium in biology. *Fed. Proc.* 45, 123-132
346. **Simonoff, M., Llabador, Y., Peers, A. M., and Simonoff, G. N.** (1984) Vanadium in human serum as determined by neutron activation analysis. *Clin. Chem.* 30, 1700-1703
347. **Shechter, Y.** (1990) Insulin-mimetic effects of vanadate. Possible implications for future treatment of diabetes. *Diabetes* 39, 1-5
348. **Schroeder, H. A., Balassa, J. J., and Tipton, I. H.** (1963) Abnormal trace metals in man-vanadium. *J. Chron. Dis.* 16, 1047-1071
349. **Nielsen, F. H.** (1995) Vanadium in mammalian physiology and nutrition. In Sigel H, Sigel A. ed. *Metal Ions in Biological Systems*. New York, Marcel Dekker. 31, 543-574
350. **Tolman, E., Barris, E., Burns, M., Pansini, A., and Partridge, R.** (1979) Effects of vanadium on glucose metabolism in vitro. *Life Sciences* 25, 1159-1164
351. **Dubyak, G., and Kleinzeller, A.** (1980) Insulin-mimetic effects of vanadate in isolated rat adipocytes. Dissociation from the effects of vanadate as a (Na⁺/K⁺) ATPase inhibitor. *J. Biol. Chem.* 255, 5306-5312
352. **Shechter, Y., and Karlisch, S. J. D.** (1980) Insulin-like stimulation of glucose oxidation in rat adipocytes by vanadyl (IV) ions. *Nature* 284, 556-558
353. **Heyliger, C., Tahiliani, A., and McNeil, J.** (1985) Effect of vanadate on elevated blood glucose and depressed cardiac performance of diabetic rats. *Science* 227, 1474-1476

354. **Kadota, S., Fantus, I., Deragon, G., Guyda, H., Hersh, B., and Posner, B.** (1987) Peroxide(s) of vanadium: a novel and potent insulin-mimetic agent which activates the insulin receptor kinase. *Biochem. Biophys. Res. Commun.* 147, 259-266
355. **McNeill, J. H., Yuen, V. G., Dai, S., and Orvig, C.** (1995) Increased potency of vanadium using organic ligands. *Mol. Cell. Biochem.* 153, 175-180
356. **Posner, B. I., Faure, R., Burgess, J. W., Bevan, A. P., Lachance, D., Zhang-Sun, G., Fantus, I. G., NG, J. B., Hall, D. A., Soo Lam, B., and Shaver, A.** (1994) Peroxovanadium compounds. A new class of potent phosphotyrosine phosphatase inhibitors which are insulin mimetics. *J. Biol. Chem.* 269(6), 4596-4604
357. **Goldfine, A., Simonson, D., Folli, F., Patti, M., and Kahn, C.** (1995) In vivo and in vitro studies of vanadate in human and rodent diabetes mellitus *Mol Cell Biochem* 153, 217-231
358. **Cohen, N., Halberstam, M., Shlimovich, P., Chang, C., Shamoan, H., and Rossetti, L.** (1995) Oral vanadyl sulfate improves hepatic and peripheral insulin sensitivity in patients with non-insulin dependent diabetes mellitus. *J. Clin. Invest.* 95, 2501-2509
359. **Crans, D. C., Mohammed, M. T., and Keramidas, A. D.** (1995) Vanadium chemistry and biochemistry of relevance for use of vanadium compounds as antidiabetic agents *Mol. Cell. Biochem.* 153, 17-24
360. **Crans, D. C.** (1994) Aqueous chemistry of labile oxovanadates: relevance to biological studies. *Comments Inorganic Chem.* 16, 1-33
361. **Shaver, A., Ng, J. B., Hall, D. A., and Posner, B. I.** (1995) The chemistry of peroxovanadium compounds relevant to insulin mimesis. *Mol. Cell. Biochem.* 153, 5-15
362. **Shechter, Y., Li, J., Meyerovitch, J., Gefel, D., Bruck, R., Elberg, G., Miller, D. S., and Shisheva, A.** (1995) Insulin-like actions of vanadate are mediated in an insulin-receptor-independent manner via non-receptor protein tyrosine kinases and protein phosphotyrosine phosphatases. *Mol. Cell. Biochem.* 153, 39-49
363. **Posner, B. I., Shaver, A., and Fantus, G.** (1990) Insulin mimetic agents : Vanadium and peroxovanadium compounds *New antidiabetic drugs*
364. **Elberg, G., Li, J., and Shechter, Y.** (1994) Vanadium activates or inhibits receptor and non-receptor protein tyrosine kinase in cell-free experiments, depending on its oxidation state. *J. Biol. Chem.* 269, 9521-9527
365. **McNeill, J. H., Yuen, V. G., Hoveyda, H. R., and Orvig, C.** (1992) Bis(maltolato)oxovanadium (IV) is a potent insulin mimic. *J. Med. Chem.* 35, 1489-1491
366. **Bowman, B. J., and Slayman, C. W.** (1979) The effects of vanadate on the plasma membrane ATPase of *Neurospora Crassa*. *J. Biol. Chem.* 254, 2928-2933
367. **Heinz, A., Rubinson, K. A., and Grantham, J. J.** (1982) The transport and accumulation of oxovanadium compounds in human erythrocytes in vitro. *J. Lab. Clin. Med.* 100, 593-612
368. **Barnes, D. M., Sykes, D. B., Shechter, Y., and Miller, D. S.** (1995) Multiple sites of vanadate and peroxovanadate action in xenopus oocytes. *J. Cell. Phys.* 162, 154-161
369. **Cantley, L. C., Josephson, L., Warner, P., Yanagisawa, M., Lechene, C., and Guidotti, G.** (1977) Vanadate is a potent (Na,K)-ATPase inhibitor found in ATP derived from muscle. *J. Biol. Chem.* 252, 7421-7423

370. **Cantley, L. C., Resh, M. D., and Guidotti, G.** (1978) Vanadate inhibits the red cell (Na⁺,K⁺) ATPase from the cytoplasmic side. *Nature* 272, 552-554
371. **Tessier, S., Chapdelaine, A., and Chevalier, S.** (1989) Effect of vanadate on protein phosphorylation and on acid phosphatase activity in canine prostate. *Mol Cell Endocrinol* 64, 87-94
372. **Gil, J., Miralpeix, M., Carreras, J., and Bartrons, R.** (1988) Insulin-like effects of vanadate on glucokinase activity and fructose 2,6 bisphosphate levels in the liver of diabetic rats. *J. Biol. Chem.* 263, 1868-1871
373. **Rider, M. H., Bartrons, R., and Hue, L.** (1990) Vanadate inhibits liver fructose-2, 6-bisphosphatase. *Eur. J. Biochem.* 190, 53-56
374. **Swarup, G., Cohen, S., and Garbers, D.** (1982) Inhibition of membrane phosphotyrosyl protein phosphatase activity by vanadate. *Biochem. Biophys. Res. Commun.* 107, 1104-1109
375. **Swarup, G., Speeg, J. K. V., Cohen, S., and Garbers, D. L.** (1982) Phosphotyrosyl-protein phosphatase of TCRC-2 cells. *J. Biol. Chem.* 257, 7298-7301
376. **Hunter, T.** (1987) A thousand and one protein kinases. *Cell* 50, 823-829
377. **Singh, J., Nordlie, R. C., and Jorgensen, R. A.** (1981) Vanadate: a potent inhibitor of multifunctional glucose-6-phosphatase *Biochim. Biophys. Acta* 678, 477-482
378. **Schulz, L. O.** (1988) Suppression of the hepatic glucose-6phosphatase system in diabetic rats by vanadate. *Ann. Nutr. Metab.* 32, 289-296
379. **Stankiewicz, P. J., Tracey, A. S., and Crans, D. C.** (1995) Inhibition of phosphate-metabolizing enzymes by oxovanadium complexes. In Sigel H, Siegel A. ed. *Metal Ions in Biological Systems*. New York, Marcel Dekker Inc., 31, 287-324a.
380. **Schwabe, U., Puckstein, c., Hammerman, H., and Sochtig, E.** (1979) Activation of adenylate cyclase by vanadate. *Nature* 277, 143-145
381. **Stankiewicz, P. J., and Tracey, A. S.** (1995) Stimulation of enzyme activity by oxovanadium complexes. In Sigel H, Siegel A. ed. *Metal Ions in Biological Systems*. New York, Marcel Dekker Inc., 31, 249-286b
382. **Fantus, I. G., Kadota, S., Deragon, G., Foster, B., and Posner, B. I.** (1989) Pervanadate [peroxides of vanadate] mimics insulin action in rat adipocytes via activation of the insulin receptor tyrosine kinase. *Biochemistry* 28(22), 8864-8871
383. **Brownsey, R. W., and Dong, G. W.** (1995) Evidence for selective effects of vanadium on adipose cell metabolism involving actions on cAMP-dependent protein kinase. *Mol. Cell Biochem.* 153, 131-137
384. **Jackson, T. K., Salhanic, A. I., Sparks, J. D., Sparks, C., Bolognino, M., and Amatruda, J. M.** (1988) Insulin-mimetic effects of vanadate in primary cultures of rat hepatocytes. *Diabetes* 37, 1234-1240
385. **Foot, E., Bliss, T., Fernandes, L., Da Costa, C., and Leighton, B.** (1992) The effects of orthovanadate, vanadyl and peroxides of vanadate on glucose metabolism in skeletal muscle preparations in vitro. *Mol. Cell. Biochem.* 109, 157-162
386. **Bosch, F., Arino, J., Comez-Foix, A. M., and Guinovart, J. J.** (1987) Glycogenolytic, noninsulin-like effects of vanadate on rat hepatocyte glycogen synthase and phosphorylase. *J. Biol. Chem.* 262, 218-222
387. **Clark, A., Fagan, J., and Mitch, W.** (1985) Selectivity of the insulin-like actions of vanadate on glucose and protein metabolism in skeletal muscle. *Biochem. J.* 232, 273-276

388. **Munoz, P., Guma, A., Camps, M., Fyrrriols, M., Testar, X., Palacin, M., and Zorzano, A.** (1992) Vanadate stimulates system A amino acid transport activity in skeletal muscle. *J. Biol. Chem.* 267(15), 10381-10388
389. **Hajjar, J. J., Dobish, M. P., and Tomicic, T. K.** (1989) Effect of chronic vanadate ingestion on amino acid and water absorption in rat intestine. *Arch. Toxicol.* 63, 29-33
390. **Klarlund, J. K.** (1985) Transformation of cells by an inhibitor of phosphatases acting on phosphotyrosine proteins. *Cell* 41, 707-717
391. **Feldman, R. A., Lowy, D. R., and Vass, W. C.** (1990) Selective potentiation of C-fps/fes transforming activity by a phosphatase inhibitor. *Oncogene Res.* 5, 187-197
392. **Kowalski, L. A., Tsang, S. S., and Davison, A. J.** (1992) Vanadate enhances transformation of bovine papillomavirus DNA-transfected C3H/10T1/2 cells. *Cancer Lett.* 64, 83-90
393. **Wang, H., and Scott, R. E.** (1995) Unique and selective mitogenic effects of vanadate on SV40-transformed cells. *Mol. Cell. Biol.* 6, 1-4
394. **Hanuske, U., Hanuske, A.-R., Marshall, M. H., Muggia, V. A., and Von Hoff, D. D.** (1987) Biphasic effect of vanadium salts on in vitro tumor colony growth. *Intern. J. Cell Cloning* 5, 170-178
395. **Cruz, T. F., Morgan, A., and Min, W.** (1995) In vitro and in vivo antineoplastic effects of orthovanadate. *Mol. Cell Biochem.* 153, 161-166
396. **Djordjevic, C.** (1995) Antitumor activity of vanadium compounds. In Sigel H, Siegel A. ed. *Metal Ions in Biological Systems.* New York, Marcel Dekker Inc., 31, 595-616
397. **Milarski, K. L., and Saltiel, A. R.** (1994) Expression of catalytically inactive syp phosphatase in 3T3 cells blocks stimulation of mitogen-activated protein kinase by insulin. *J. Biol. Chem.* 269, 21239-21243
398. **Xiao, S., Rose, D. W., Sasaoka, T., Maegawa, H., Burke, T. R., Roller, P. P., Shoelson, S. E., and Olefsky, J. M.** (1994) Syp (SH-PTP2) is a positive mediator of growth factor-stimulated mitogenic signal transduction. *J. Biol. Chem.* 269, 21244-21248
399. **Baratte, B., Meijer, L., Galaktionov, K., and Beach, D.** (1992) Screening for antimitotic compounds using the cdc25 tyrosine phosphatase an activator of the mitosis-inducing p34 cdc2/cyclin Bcdc13 protein kinase. *Anticancer Res* 12, 873-880
400. **Hamaguchi, T., Sudo, T., and Osada, H.** (1995) RK-682, a potent inhibitor of protein tyrosine phosphatase arrested the mammalian cell cycle progression at G1 phase. *FEBS Lett.* 372, 54-58
401. **Faure, R., Vincent, M., Dufour, M., Shaver, A., and Posner, B. I.** (1995) Arrest at the G2/M transition of the cell cycle by protein-tyrosine phosphatase inhibition: studies on a neuronal and a glial cell line. *J. Cell Biochem.* 59, 389-401
402. **Grinstein, S., Furuya, W., Lu, D. J., and Mills, B. G.** (1990) Vanadate stimulates oxygen consumption and tyrosine phosphorylation in electroporated human neutrophils. *J. Biol. Chem.* 265, 318-327
403. **Haqu, s. J., Flati, V., Deb, A., and Williams, B. R. G.** (1995) Role of protein-tyrosine phosphatases in stat 1a-mediated cell signaling. *J. Biol. Chem.* 270, 25709-25714
404. **Roupas, P., and Herington, A. C.** (1994) Postreceptor signaling mechanisms for growth hormone. *Trends Endocrinol. metab.* 5, 154-158
405. **Fantus, I. G., George, R., Tang, S., Chong, P., and Poznansky, M. J.** (1996) The insulin-mimetic agent vanadate promotes receptor endocytosis and inhibits

- intracellular ligand-receptor degradation by a mechanism distinct from the lysosomotropic agents. *Diabetes* 45, 1084-1093
406. **Orvig, C., Thompson, K. H., Battell, M., and McNeill, J. H.** (1995) Vanadium compounds as insulin mimics. In Sigel H, Siegel A. ed. *Metal Ions in Biological Systems*. New York, Marcel Dekker Inc., 31, 575-594
407. **Brichard, S. M., and Henquin, J.-C.** (1995) The role of vanadium in the management of diabetes. *Trends Pharmacol Sci* 16, 265-270
408. **Pederson, R. A., Ramanadham, S., Buchan, A. M. J., and McNeill, J. H.** (1989) Long-term effects of vanadyl treatment on streptozotocin-induced diabetes in rats. *Diabetes* 38, 1390-1395
409. **Brichard, S. M., Okitolonda, W., and Henquin, J. C.** (1988) Long term improvement of glucose homeostasis by vanadate treatment in diabetic rats. *Endocrinology* 123, 2048-2053
410. **Meyerovitch, J., Farfel, Z., Sack, J., and Schechter, J.** (1987) Oral administration of vanadate normalizes blood glucose levels in streptozotocin-treated rats. Characterization and mode of action. *J. Biol. Chem.* 262, 6658-6662
411. **Bendayan, M., and Gingras, D.** (1989) Effect of vanadate administration on blood glucose and insulin levels as well as on the exocrine pancreatic function in streptozotocin-diabetic rats. *Diabetologia* 32(561-567)
412. **Domingo, J. L., Gomez, L., Llobet, J. M., Corbella, J., and Keen, C. L.** (1991) Improvement of glucose homeostasis by oral vanadyl or vanadate treatment in diabetic rats is accompanied by negative side effects. *Pharmacol. Toxicol.* 68, 249-253
413. **Cam, M., Pederson, R., Brownsey, R., Cros, G., and McNeill, J.** (1993a) Long term effectiveness of oral vanadyl sulfate in streptozotocin-diabetic rats. *Diabetologia* 36, 218-224
414. **Yuen, V. G., Orvig, C., and McNeill, J. H.** (1993) Glucose lowering effects of a new vanadium complex, bis(maltolato)oxovanadium(IV). *Can. J. Physiol. Pharmacol.* 71, 263-269
415. **Rossetti, L., and Laughlin, M. R.** (1989) Correction of chronic hyperglycemia with vanadate, but not with phlorizin, normalizes in vivo glycogen repletion and in vitro glycogen synthase activity in diabetic skeletal muscle. *J. Clin. Invest.* 84, 892-899
416. **Rossetti, L., Giaccari, A., Klein-Robbenhaar, E., and Vogel, L. R.** (1990) Insulinomimetic properties of trace elements and characterization of their in vivo mode of action. *Diabetes* 39, 1243-1250
417. **Battell, M., Yuen, V., and McNeill, J.** (1992) Treatment of BB rats with vanadyl sulfate. *Pharmacol. Commun.* 1, 291-301
418. **Yale, J. F., Vigeant, C., Nardolillo, C., Chu, Q., Yu, J.-Z., Shaver, A., and Posner, B. I.** (1995) In vivo effects of peroxovanadium compounds in BB rats. *Mol. Cell. Biochem.* 153, 181-190
419. **Meyerovitch, J., Rothenberg, P., Shechter, Y., Bonner-Weir, S., and Kahn, C.** (1991) Vanadate normalizes hyperglycemia in two mouse models of non-insulin-dependent diabetes mellitus. *J. Clin. Invest.* 87, 1286-1294
420. **Brichard, S. M., Bailey, C. J., and Henquin, J. C.** (1990) Marked improvement of glucose homeostasis in diabetic ob/ob mice given oral vanadate. *Diabetes* 39, 1326-1332
421. **Brichard, S. M., Pottier, A. M., and Henquin, J. C.** (1989) Long term improvement of glucose homeostasis by vanadate in obese hyperinsulinemic fa/fa rats. *Endocrinology* 125, 2510-2516

422. **Brichard, S. M., Ongemba, L. N., and Henquin, J. C.** (1992) Oral vanadate decreases muscle insulin resistance in obese fa/fa rats. *Diabetologia* 35, 522-527
423. **Eriksson, J. W., Lonroth, P., and Smith, U.** (1992) Vanadate increases cell surface insulin binding and improves insulin sensitivity in both normal and insulin-resistant rat adipocytes. *Diabetologia* 35, 510-516
424. **Fantus, I., Ahmad, F., and Deragon, G.** (1990) Vanadate augments insulin binding and prolongs insulin action in rat adipocytes. *Endocrinology* 127, 2716-2725
425. **Carey, J. O., Azevedo, J. L., Morris, P. G., Pories, W. J., and Dohm, G. L.** (1995) Okadaic acid, vanadate and phenylarsine oxide stimulate 2-deoxyglucose transport in insulin-resistant human skeletal muscle. *Diabetes* 44, 682-688
426. **Halberstam, M., Cohen, N., Shlimovich, P., Rossetti, L., and Shamon, H.** (1996) Oral vanadyl sulfate improves insulin sensitivity in NIDDM but not in obese nondiabetic subjects. *Diabetes* 45, 659-666
427. **Blondel, O., Bailte, D., and Portha, B.** (1989) In vivo insulin resistance in streptozotocin-diabetic rats-evidence for reversal following oral vanadate treatment. *Diabetologia* 32, 185-190
428. **Ramanadham, S., Brownsey, R., Cros, G., Mongold, J., and McNeill, J.** (1989b) Sustained prevention of myocardial abnormalities in diabetic rats following withdrawal from oral vanadyl treatment. *Metabolism* 38, 1022-1028
429. **Fischer, E., Charbonneau, H., and Tonks, N.** (1991) Protein tyrosine phosphatases a diverse family of intracellular and transmembrane enzymes. *Science* 253, 401-406
430. **Goldstein, B. J.** (1992) Protein-tyrosine phosphatases and the regulation of insulin action. *J. Cell. Biochem.* 48, 33-42
431. **Meyerovitch, J., Backer, J., Csermely, P., Shoelson, S., and Kahn, C.** (1992) Insulin differentially regulates protein phosphotyrosine phosphatase activity in rat hepatoma cells. *Biochemistry* 31, 10338-10344
432. **Faure, R., Baquiran, G., Bergeron, J. J., and Posner, B. I.** (1992) The dephosphorylation of insulin and epidermal growth factor receptors. Role of endosome-associated phosphotyrosine phosphatase(s). *J. Biol. Chem.* 267, 11215-11221
433. **Fantus, I. G., Ahmad, F., and Deragon, G.** (1994) Vanadate augments insulin-stimulated insulin receptor kinase activity and prolongs insulin action in rat adipocytes. Evidence for transduction of amplitude of signaling into duration of response. *Diabetes* 43, 375-383
434. **Tamura, S., Brown, T. A., Whipple, J. H., Fujita-Yamaguchi, J., Dubler, R. E., Cheng, K., and Lerner, J.** (1984) A novel mechanism of the insulin-like effects of vanadate on glycogen synthase in rat adipocytes. *J. Biol. Chem.* 259, 6650-6658
435. **Pugazhenti, S., and Khandelwal, R. L.** (1993) Does the insulin-mimetic action of vanadate involve insulin receptor kinase? *Mol. Cell. Biochem.* 127/128, 211-218
436. **Cordera, R., Andraghetti, G., DeFronzo, R. A., and Rossetti, L.** (1990) Effect of *in vivo* vanadate treatment on insulin receptor tyrosine kinase activity in partially pancreatectomized diabetic rats. *Endocrinology* 126, 2177-2183
437. **Meyerovitch, J., Backer, J. M., and Kahn, C. R.** (1989) Hepatic phosphotyrosine phosphatase activity and its alterations in diabetic rats. *J. Clin. Invest.* 84, 976-983

438. **Strout, H., Vicario, P., Saperstein, R., and Slater, E.** (1989) The insulin-mimetic effect of vanadate is not correlated with insulin receptor kinase activity nor phosphorylation in mouse diaphragm in vivo. *Endocrinology* 124, 1918-1924
439. **Mooney, R. A., Bordwell, K. L., Luhowskyj, S., and Casnellie, J. E.** (1989) The insulin-like effect of vanadate on lipolysis in rat adipocytes is not accompanied by an insulin-like effect on tyrosine phosphorylation. *Endocrinology* 124
440. **Green, A.** (1986) The insulin-like effect of sodium vanadate on adipocyte glucose transport is mediated at a post-insulin-receptor level. *Biochem. J.* 238, 663-669
441. **Shisheva, A., and Shechter, Y.** (1992) Quercetin selectively inhibits insulin receptor function in vitro and the bioresponses of insulin and insulinomimetic agents in rat adipocytes. *Biochemistry* 31, 8059-8063
442. **Shisheva, A., and Shechter, Y.** (1993) Mechanism of pervanadate stimulation and potentiation of insulin-activated glucose transport in rat adipocytes: dissociation from vanadate effect. *Endocrinology* 133, 1562-1568
443. **Kadota, S., Fantus, I. G., Deragon, G., Guyda, H. J., and Posner, B. I.** (1987) Stimulation of insulin-like growth factor II receptor binding and insulin receptor kinase activity in rat adipocytes. Effects of vanadate and H₂O₂. *J. Biol. Chem.* 262(17), 8252-8256
444. **Contreres, J. O., Dumas, V., and Posner, B. I.** (1996) The insulin receptor (IR) associated phosphotyrosine phosphatase (PTP): Its key role in insulin signalling. (Abstract P1-45) 10th International Congress of Endocrinology. Program and Abstracts I, 146
445. **Heffetz, D., Rutter, W. J., and Zick, Y.** (1992) The insulinomimetic agents H₂O₂ and vanadate stimulate tyrosine phosphorylation of potential target proteins for the insulin receptor kinase in intact cells. *Biochem. J.* 288, 631-635
446. **Shisheva, A., and Shechter, Y.** (1993) Role of cytosolic tyrosine kinase in mediating insulin-like actions of vanadate in rat adipocytes. *J. Biol. Chem.* 268, 6463-6469
447. **Sun, X. J., Pons, S., Asano, T., Myers, M. G., Glasheen, E., and White, M. F.** (1996) The Fyn tyrosine kinase binds Irs-1 and forms a distinct signaling complex during insulin stimulation. *J. Biol. Chem.* 271, 10583-10587
448. **D'Onofrio, F., Le, M., Chiasson, J., and Srivastava, A.** (1994) Activation of mitogen activated protein (MAP) kinases by vanadate is independent of insulin receptor autophosphorylation. *FEBS Lett* 340, 269-275
449. **Sun, H., Tonks, N. K., and Bar-Sagi, D.** (1994) Inhibition of Ras-induced DNA synthesis by expression of the phosphatase MKP-1. *Science* 266, 285-288
450. **Pandey, S. K., Chiasson, J. L., and Srivastava, A. K.** (1995) Vanadium salts stimulate mitogen-activated protein (MAP) kinases and ribosomal S6 kinases. *Mol. Cell. Biochem.* 153, 69-78
451. **Hei, Y.-J., Chen, X., Pelech, S., Diamond, J., and McNeill, H.** (1995) Skeletal muscle mitogen-activated protein kinases and ribosomal S6 kinases. Suppression in chronic diabetic rats and reversal by vanadium. *Diabetes* 44, 1147-1155
452. **Paquet, M. R., Romanek, R. J., and Sargeant, R. J.** (1992) Vanadate induces the recruitment of Glut-4 glucose transporter to the plasma membrane of rat adipocytes. *Mol. Cell Biochem.* 109, 149-155
453. **Mountjoy, K. G., and Flier, J. S.** (1990) Vanadate regulates glucose transporter (Glut1) expression in NIH3T3 mouse fibroblasts. *Endocrinology* 127, 2025-2034

454. **Strout, H. V., Vicario, P. P., Biswas, C., Saperstein, R., Brady, E. J., Pilch, P. F., and Berger, J.** (1990) Vanadate treatment of streptozotocin diabetic rats restores expression of the insulin-responsive glucose transporter in skeletal muscle. *Endocrinology* 126(5), 2728-32
455. **Brichard, S. M., Assimakopoulos-Jeannet, F., and Jeanrenaud, B.** (1992) Vanadate treatment markedly increases glucose utilization in muscle of insulin-resistant fa/fa rats without modifying glucose transporter expression. *Endocrinology* 131, 311-317
456. **Kadota, S., Fantus, I. G., Hersh, B., and Posner, B. I.** (1986) Vanadate stimulation of IGF binding to rat adipocytes. *Biochem. Biophys. Res. Comm.* 138, 174-178
457. **Cros, G. H., Cam, M. C., Serrano, J. J., Ribes, G., and McNeill, J. H.** (1995) Long-term antidiabetic activity of vanadyl after treatment withdrawal: Restoration of insulin secretion? *Mol. Cell. Biochem.* 153, 191-195
458. **Poucheret, P., Gross, R., Cadene, A., Mantegueti, M., Serrano, J. J., Ribes, G., and Cros, G.** (1995) Long-term correction of STZ-diabetic rats after short-term i.p. VOSO₄ treatment: Persistence of insulin secreting capacities assessed by isolated pancreas studies. *Mol. Cell. Biochem.* 153, 197-204
459. **Malabu, U. H., Dryden, S., McCarthy, H. D., Kilpatrick, A., and Williams, G.** (1994) Effects of chronic vanadate administration in the STZ-induced diabetic rat. The antihyperglycemic action of vanadate is attributable entirely to its suppression of feeding. *Diabetes* 43, 9-15
460. **Schwartz, M. W., Figlewicz, D. P., Baskin, D. G., Woods, S. C., and Porte, D. J.** (1992) Insulin in the brain: a hormonal regulator of energy balance. *Endocr. rev.* 13, 387-414
461. **Madsen, K., Porter, V., and Fedorak, R.** (1993) Oral vanadate reduces Na⁺-dependent glucose transport in rat small intestine. *Diabetes* 42, 1126-1132
462. **Yuen, V. G., Orvig, C., and McNeill, J. H.** (1995) Comparison of the glucose lowering properties of vanadyl sulfate and bis(maltolato)oxovanadium (IV) following acute and chronic administration. *Can. J. Phys. Pharmacol.* 73, 55-64
463. **Domingo, J. L., Gomez, M., Sanchez, D. J., Llobet, J. M., and Keen, C. L.** (1995) Toxicology of vanadium compounds in diabetic rats: The action of chelating agents on vanadium accumulation. *Mol. Cell. Biochem.* 153, 233-240
464. **Yale, J. F., Lachance, D., Bevan, A. P., Vigeant, C., Shaver, A., and Posner, B. I.** (1995) Hypoglycemic effects of peroxovanadium compounds in Sprague-Dawley and BB rats. *Diabetes* 44, 1274-1279
465. **Leonard, A., and Gerber, G. B.** (1994) Mutagenicity, carcinogenicity and teratogenicity of vanadium compounds. *Mutation Res* 317, 81-88
466. **Hamel, F. G., and W.C., D.** (1995) The relationship between insulin and vanadium metabolism in insulin target tissues. *Mol. Cell. Biochem.* 153, 95-102
467. **Ferrannini, E., Reichard, G. A., Bjorkman, O., Wahren, J., Pilo, A., Olsson, M., and DeFronzo, R. A.** (1985) The disposal of an oral glucose load in normal subjects: a quantitative study. *Diabetes* 34, 580-588
468. **Kelley, D., Mitrakou, A., Marsh, H., Schwenk, F., Benn, J., Sonneberg, G., Berger, M., Sonksen, P., and Gerich, J.** (1988) Skeletal muscle glycolysis, oxidation, and storage of an oral glucose load. *J.Clin. Invest.* 81, 1563-1571

469. **Bonadonna, R., Saccomani, M., Cobelli, C., and DeFronzo, R.** (1993) Effect of insulin on system A amino acid transport in human skeletal muscle *J. Clin. Invest.* 91, 514-521
470. **Zorzano, A., Balon, T., Garetto, L., Goodman, M., and Ruderman, N. B.** (1985) Muscle α -aminoisobutyric acid transport after exercise: enhanced stimulation by insulin. *Am. J. Physiol.* 248, E546-E552
471. **Duckworth, W. C., Solomon, S. S., Liepnieks, J., Hamel, F. G., Hand, S., and Peavy, D. E.** (1988) Insulin-like effects of vanadate in isolated rat adipocytes. *Endocrinology* 122, 2285-2289
472. **Torossian, K., Freedman, D., and Fantus, I. G.** (1988) Vanadate downregulated cell surface insulin and growth hormone receptors and inhibits insulin receptor degradation in cultured human lymphocytes. *J. Biol. Chem.* 263, 9353-9359
473. **Cros, G., Mongold, J., Serrano, J., Ramanadham, S., and McNeill, J.** (1992) Effects of vanadyl derivatives on animal models of diabetes *Mol. cell Biochem.* 109, 163-166
474. **Pugazhenti, S., Angel, J., and Khandelwal, R.** (1991) Long term effects of vanadate treatment on glycogen metabolizing and lipogenic enzymes of liver in genetically diabetic (db/db) mice. *Metabolism* 40, 941-946
475. **Ramanadham, S., Mongold, J., Brownsey, R., Cros, G., and McNeill, J.** (1989) Vanadyl sulfate in the treatment of diabetes mellitus in rats. *Am. J. Physiol.* 257, H904-H911
476. **Leighton, B., Cooper, G., Da Costa, C., and Foot, E.** (1991) Peroxovanadates have full insulin-like effects on glycogen synthesis in normal and insulin-resistant skeletal muscle. *Biochem. J.* 276, 289-292
477. **Ewart, H. S., and Klip, A.** (1995) Hormonal regulation of the Na^+/K^+ -ATPase: mechanisms underlying rapid and sustained changes in pump activity. *Am. J. Physiol.* 269, C295-C311
478. **Tsiani, E., Ramlal, T., Leiter, L. A., Klip, A., and Fantus, I. G.** (1995) Stimulation of glucose uptake and increased plasma membrane content of glucose transporters in L6 skeletal muscle cells by the sulfonylureas gliclazide and glyburide. *Endocrinology* 136, 2505-2512
479. **Munoz, P., Roseblatt, M., Testar, X., Palacin, M., and Zorzano, A.** (1995) Isolation and characterization of distinct domains of sarcolemma and T-tubules from rat skeletal muscle. *Biochem. J.* 307, 273-280
480. **Venkatesan, N., Avidan, A., and Davidson, M. B.** (1991) Anti-diabetic action of vanadyl in rats independent of *in vivo* insulin receptor kinase activity. *Diabetes* 40, 492-498
481. **Bruck, P., Prigozin, H., Krepel, Z., Rotenberg, P., Shechter, Y., and Bar-Meir, S.** (1991) Vanadate inhibits glucose output from isolated perfused rat liver. *Hepatology* 14, 540-544
482. **Bevan, A. P., Burgess, J. W., Yale, J. F., Drake, P. G., Lachance, D., Baquiran, G., Shaver, A., and Posner, B. I.** (1995) In vivo insulin mimetic effects of pV compounds: role for tissue targeting in determining potency. *Am. J. Physiol.* 268, E60-E66
483. **Yamauchi, K., Ribon, V., Saltier, A. R., and Pessin, J. E.** (1995) Identification of the major SHPTP2-binding protein that is tyrosine-phosphorylated in response to insulin. *J. Biol. Chem.* 270, 17716-17722

484. **Hadari, Y. R., Tzahar, E., Navid, O., Rothenberg, P., Roberts Jr, C. T., LeRoith, D., yarden, Y., and Zick, Y.** (1992) Insulin and insulinomimetic agents induce activation of phosphatidylinositol 3-kinase upon its association with pp 185 (IRS-1) in intact rat livers. *J. Biol. Chem.* 267, 17483-17486
485. **Berger, J., Hayes, N., Szalkowski, D. M., and Zhang, B.** (1994) PI 3-kinase activation is required for insulin stimulation of glucose transport into L6 myotubes. *Biochem. Biophys. Res. Comm.* 205(1), 570-576
486. **Ida, M., Imai, K., Hashimoto, S., and Kawashima, H.** (1996) Pervanadate stimulation of wortmannin-sensitive and -resistant 2-deoxyglucose transport in adipocytes. *Biochem. Pharmacol.* 51, 1061-1067
487. **Groom, L. A., Sneddon, A. A., Alessi, D. R., Dowd, S., and Keyse, S. M.** (1996) Differential regulation of the MAP, SAP, and RK/p38 kinases by Pyst1, a novel cytosolic dual-specificity phosphatase. *EMBO J.* 15, 3621-3632
488. **Kyriakis, J. M., Banerjee, P., Nikolakaki, E., Dai, T., Rubie, E., Ahmad, M., Avruch, J., and Woodgett, J. R.** (1994) The stress-activated protein kinase subfamily of c-Jun kinases. *Nature* 369, 156-160
489. **Zhang, S., Han, J., Sells, M. A., Chernoff, J., Knaus, U. G., Ulevitch, R. J., and Bokoch, G. M.** (1995) Rho family GTPases regulate p38 mitogen-activated protein kinase through the downstream mediator PAK1. *J. Biol. Chem.* 270, 23934-23936
490. **Miller, B. S., Shankavaram, U. T., Horney, M. J., Core, A. C. S., Kurtz, D. T., and Rosenzweig, S. A.** (1996) Activation of cJun NH2-terminal kinase/stress-activated protein kinase by insulin. *Biochemistry* 35, 8769-8775
491. **Bagrodia, S., Derijard, B., Davis, R. J., and Cerione, R. A.** (1995) Cdc42 and PAK-mediated signaling leads to Jun kinase and p38 mitogen-activated protein kinase activation. *J. Biol. Chem.* 270, 27995-27998
492. **Coso, O. A., Chiariello, M., Yu, J.-C., Teramoto, H., Crespo, P., Xu, N., Miki, T., and Gutkind, J. S.** (1995) The small GTP-binding proteins Rac1 and Cdc42 regulate the activity of the JNK/SAPK signaling pathway. *Cell* 81, 1137-1146
493. **Tsakiridis, T., Taha, C., Grinstein, S., and Klip, A.** (1996) Insulin activates a p21-activated kinase in muscle cells via phosphatidylinositol 3-kinase. *J. Biol. Chem.* 271, 19664-19667

COPYRIGHT RELEASE AUTHORIZATIONS

**Evangelia Tsiani
Banting & Best Diabetes Centre
MBRC 4-926, The Toronto Hospital
General Division
200 Elizabeth Street
Toronto, Ontario
M5G 2C4**

**Phone (416) 586-8665
FAX (416) 586-8785**

September 6th, 1996

FAX (301) 571-1224

**Editor, Journal of Biological Chemistry,
9650 Rockville Pike
Bethesda, MD 20814-3997**

Dear Sir,

I am completing a doctoral thesis at the University of Toronto entitled "Regulation of metabolic functions in L6 muscle cells by sulfonylureas and the protein tyrosine phosphatase inhibitors vanadate and pervanadate". I would like permission to allow inclusion of the following material in the thesis and permission for the National Library to make use of the thesis (i.e. reproduce, loan, distribute, or sell copies of the thesis by any means and in any form or format).

These rights will in no way restrict republication of the material in any other form by you or by others authorized by you.

The excerpts to be reprinted are : Figure 1 as appears in:

Structure and function of mammalian facilitative sugar transporters" by Graeme I. Bell, Charles F. Burant, Jun Takeda and Gwyn W. Gould (1993) J. Biol. Chem. 268 (26) 19161-19164.

If these arrangements meet with your approval, please fax me your reply. Thank you for your assistance in this matter.

Yours sincerely,

Evangelia Tsiani

PERMISSION GRANTED
center for permission obtaining that of the author



for the use of the
THE AMERICAN SOCIETY FOR BIOCHEMISTRY
AND MOLECULAR BIOLOGY

SEP 10 1996

**Evangelia Tsiani
Banting & Best Diabetes Centre
MBRC 4-926, The Toronto Hospital
General Division
200 Elizabeth Street
Toronto, Ontario
M5G 2C4**

**Phone (416) 586-8865
FAX (416) 586-8785**

September 6th, 1996

Fax No: (310) 657-9656

**Editor, Endocrinology
Cedars-Sinai Medical Center
8700 Beverly Blvd, B-138
Los Angeles CA, 90048-1865**

Dear Sir,

I am completing a doctoral thesis at the University of Toronto entitled Regulation of metabolic functions in L6 muscle cells by sulfonylureas and the protein tyrosine phosphatase inhibitors vanadate and pervanadate. I would like permission to allow inclusion of the following material in the thesis and permission for the National Library to make use of the thesis (i.e. reproduce, loan, distribute, or sell copies of the thesis by any means and in any form or format).

These rights will in no way restrict republication of the material in any other form by you or by others authorized by you.

The excerpts to be reprinted are :Figures 1-8 and Table 1 as appears in:

Stimulation of Glucose Uptake and Increased Plasma Membrane Content of Glucose Transporters in L6 Skeletal Muscle Cells by the Sulfonylureas Gliclazide and Glyburide by Evangelia Tsiani, Toosie Ramlal, Lawrence A. Leiter, Amira Klip and I. George Fantus (1995) Endocrinology 136 (6):2505-2512.

If these arrangements meet with your approval, please fax me your reply. Thank you for your assistance in this matter.

Yours sincerely,

Evangelia Tsiani

Permission granted by the copyright owner, contingent upon the consent of the author(s); provided complete credit is given to the original source and © owner, The Endocrine Society. Credit line must contain: initials and last name(s) of author(s); title of article; name of journal; volume #: issue #: inclusive pages; year of publication; © The Endocrine Society.

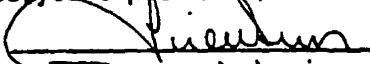
Per:  Signature
Francis Admin Asst. Name/Title
9/18/96 Date

ENDOCRINE SOCIETY JOURNAL PUBLICATIONS DEPT.

08.08.96 03:42PM *DEPT. OF ENDOCRINOLOGY

**Evangelia Tsiani
Banting & Best Diabetes Centre
MBRC 4-826, The Toronto Hospital
General Division
200 Elizabeth Street
Toronto, Ontario
M5G 2C4**

**Phone (416) 586-8665
FAX (416) 586-8785**

September 6th, 1996

FAX 205-934-2377

**Dr. Dale Benos, Editor
American Journal of Physiology
Cell Physiology
Department of Physiology and Biophysics
University of Alabama at Birmingham
BHSB706**

Dear Sir,

I am completing a doctoral thesis at the University of Toronto entitled Regulation of metabolic functions in L6 muscle cells by sulfonylureas and the protein tyrosine phosphatase inhibitors vanadate and pervanadate". I would like permission to allow inclusion of the following material in the thesis and permission for the National Library to make use of the thesis (i.e. reproduce, loan, distribute, or sell copies of the thesis by any means and in any form or format).

These rights will in no way restrict republication of the material in any other form by you or by others authorized by you.

The excerpts to be reprinted are :Figures 1-6 and Tables 1,2, and 3 as appears in:

The Insulin Mimetic Agents Vanadate and Parvanadate Stimulate Glucose but Inhibit Amino Acid Uptake" by Evangelia Tsiani, Nadine Abdullah and I.George Fantus. American Journal of Physiology: Cell Physiology (in press).

If these arrangements meet with your approval, please fax me your reply. Thank you for your assistance in this matter.

Yours sincerely,

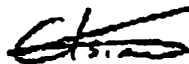

Evangelia Tsiani

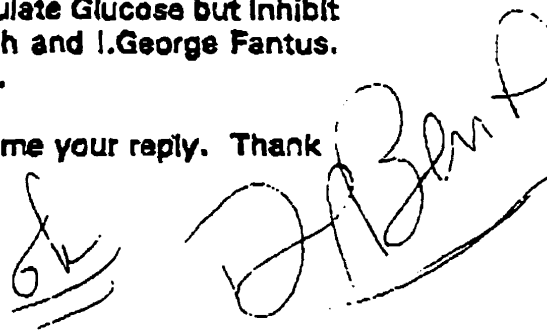

Evangelia Tselni
Banting & Best Diabetes Centre
MBRC 4-926, The Toronto Hospital
General Division
200 Elizabeth Street
Toronto, Ontario
M5G 2C4

Phone (416) 586-8665
FAX (416) 586-8785

September 6th, 1996

FAX (204) 233-6723

Dr. Naranjan S. Dhalla, Editor-in-Chief
Molecular and Cellular Biochemistry
St. Boniface General Hospital Research Centre
University of Manitoba
351 Tache Avenue
Winnipeg, Manitoba R2H 2A6

Dear Dr. Dhalla,

I am completing a doctoral thesis at the University of Toronto entitled "Regulation of metabolic functions in L6 muscle cells by sulfonylureas and the protein tyrosine phosphatase inhibitors vanadate and pervanadate". I would like permission to allow inclusion of the following material in the thesis and permission for the National Library to make use of the thesis (i.e. reproduce, loan, distribute, or sell copies of the thesis by any means and in any form or format).

These rights will in no way restrict republication of the material in any other form by you or by others authorized by you.

The excerpts to be reprinted are :Figures 8 as appears in:

The chemistry of peroxovanadium compounds relevant to insulin mimesis" by Alan Shaver, Jesse B. Ng, David, A. Hall and Barry, I. Posner. Molecular and Cellular Biochemistry 153:5-15 (1995).

If these arrangements meet with your approval, please fax me your reply. Thank you for your assistance in this matter.

Yours sincerely,

Evangelia Tselni



*Melissa -
Please fax to*

Thanks!

*To Bob Hollenbeck
for sending the
permission*

PERMISSION GRANTED PROVIDED THAT
COMPLETE ACKNOWLEDGEMENT IS GIVEN TO
THE ORIGINAL SOURCE OF PUBLICATION

Pat Hollenbeck
DATE _____ FROM _____ AT PUBLISHER
ADDRESS _____

IMAGE EVALUATION TEST TARGET (QA-3)

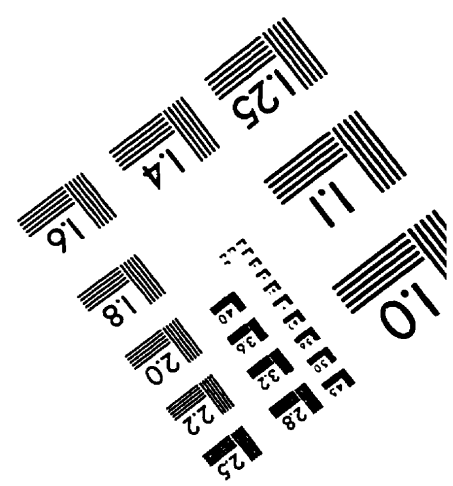
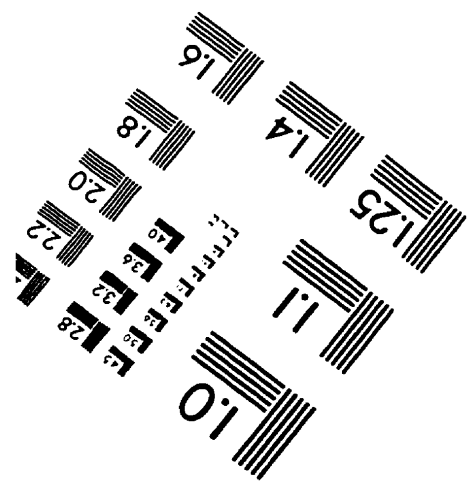
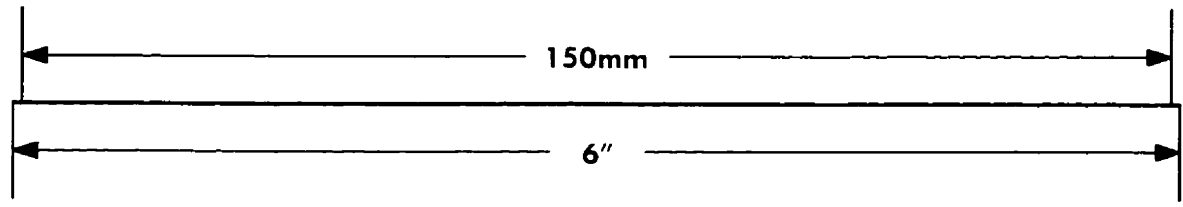
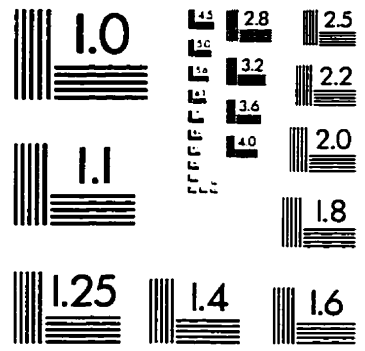
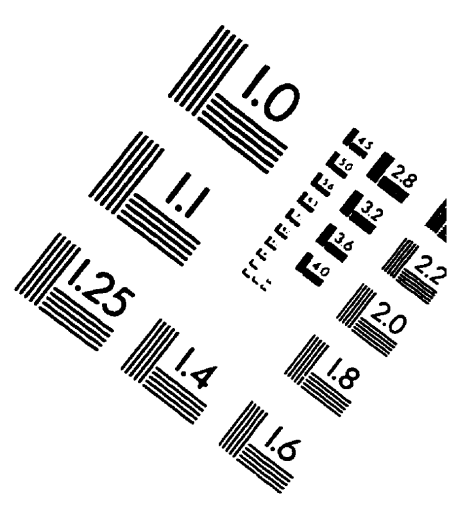
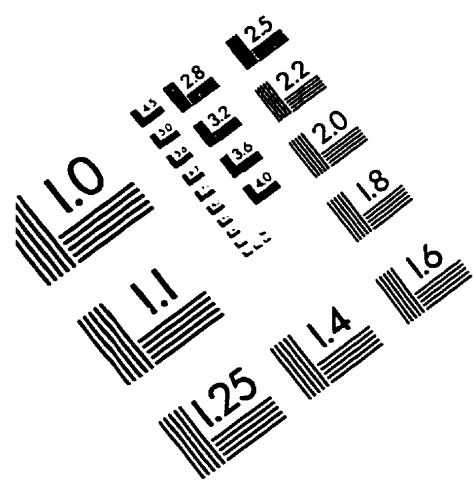

APPLIED IMAGE, Inc
 1653 East Main Street
 Rochester, NY 14609 USA
 Phone: 716/482-0300
 Fax: 716/288-5989

© 1993, Applied Image, Inc., All Rights Reserved